

Errata

Title & Document Type: 8663A Signal Generator Operation and Calibration Manual

Manual Part Number: 08663-90069

Revision Date: August 1, 1991

HP References in this Manual

This manual may contain references to HP or Hewlett-Packard. Please note that Hewlett-Packard's former test and measurement, semiconductor products and chemical analysis businesses are now part of Agilent Technologies. We have made no changes to this manual copy. The HP XXXX referred to in this document is now the Agilent XXXX. For example, model number HP8648A is now model number Agilent 8648A.

About this Manual

We've added this manual to the Agilent website in an effort to help you support your product. This manual provides the best information we could find. It may be incomplete or contain dated information, and the scan quality may not be ideal. If we find a better copy in the future, we will add it to the Agilent website.

Support for Your Product

Agilent no longer sells or supports this product. You will find any other available product information on the Agilent Test & Measurement website:

www.tm.agilent.com

Search for the model number of this product, and the resulting product page will guide you to any available information. Our service centers may be able to perform calibration if no repair parts are needed, but no other support from Agilent is available.

3048 MS

HP 8663A

SYNTHESIZED SIGNAL GENERATOR

Including Options 001, 002, & 003

Operation and Calibration Manual

SERIAL NUMBERS

This manual applies directly to instruments with serial numbers prefixed:

2234A to 2927A and all *MAJOR* changes that apply to your instrument.

rev. 12AUG91

For additional important information about serial numbers, refer to "INSTRUMENTS COVERED BY THIS MANUAL" in Section 1.

Second Edition

This material may be reproduced by or for the U.S. Government pursuant to the Copyright License under the clause at DFARS 52.227-7013 (APR 1988).

Copyright © HEWLETT-PACKARD COMPANY 1982
EAST 24001 MISSION AVENUE, TAF C-34, SPOKANE, WASHINGTON, U.S.A. 99220

Operation and Calibration Manual HP Part 08663-90069

Other Documentation Available

Service Manual (Volume 1, 2, 3, 4) HP Part 08663-90071

Microfiche Operation and Calibration Manual HP Part 08663-90070

Microfiche Service Manual HP Part 08663-90072

Printed in U.S.A. : November 1989



**HEWLETT
PACKARD**

Done

Documentation Update Service Packet

5

HP 8663A Operation and Calibration Manual

rev12 AUG91

HP 8663A

SYNTHESIZED SIGNAL GENERATOR

Including Options 001, 002, & 003

Operation and Calibration Manual

SERIAL NUMBERS

This manual applies directly to instruments with serial numbers prefixed:

2234A to 2927A and all *MAJOR* changes that apply to your instrument.

rev.12MAR90

For additional important information about serial numbers, refer to "INSTRUMENTS COVERED BY THIS MANUAL" in Section 1.

Second Edition

This material may be reproduced by or for the U.S. Government pursuant to the Copyright License under the clause at DFARS 52.227-7013 (APR 1988).

Copyright © HEWLETT-PACKARD COMPANY 1982
EAST 24001 MISSION AVENUE, TAF C-34, SPOKANE, WASHINGTON, U.S.A. 99220

Operation and Calibration Manual HP Part 08663-90069

Other Documentation Available

Service Manual (Volume 1, 2, 3, 4) HP Part 08663-90071

Microfiche Operation and Calibration Manual HP Part 08663-90070

Microfiche Service Manual HP Part 08663-90072

Printed in U.S.A. : November 1989



HEWLETT
PACKARD

Section 1 GENERAL INFORMATION

(12 Mar 90)
old

1-1. INTRODUCTION

This manual contains information required to install, operate, test, adjust, and service the Hewlett-Packard Model 8663A Signal Generator. The Model 8663A will generally be referred to as the signal generator throughout this manual.

The HP 8663A Operating and Service manual is composed of an Operation and Calibration Manual and a three volume service manual. The Operation and Calibration Manual contains the following sections:

1. General Information
2. Installation
3. Operation
4. Performance Tests
5. Adjustments

The Service Manual (Volumes 1, 2 and 3) contain the following Sections:

6. Replaceable Parts
7. Manual Changes
8. Service

The HP part number for the Operation and Calibration Manual is shown on the title page of this manual. Part numbers for the Service Manual are shown on the title pages of Volumes 1, 2 and 3 of the Service Manual.

1-2. SPECIFICATIONS

Instrument specifications are listed in Table 1-1. These specifications are the performance standards or limits against which the instrument can be tested. Supplemental characteristics are not specifications but are typical characteristics included as additional information for the user.

1-3. SAFETY CONSIDERATIONS

This product is a Safety Class I instrument (provided with a protective earth terminal). The signal generator and all related documentation must be reviewed for familiarization with safety markings and instructions before operation. Refer to the Safety Considerations page found at the beginning of this manual for a summary of general safety information.

Safety information for installation and operation is found in appropriate places throughout this manual.

1-4. INSTRUMENTS COVERED BY MANUAL

Attached to the instrument is a serial number plate. The serial number is in the form: 0000A00000. The serial number is composed of two parts; the first four digits and the letter are the serial number prefix and the last five digits are the suffix. The prefix is the same for all identical instruments; it changes only when a change is made to the instrument. The suffix, however, is assigned sequentially and is different for each instrument. The contents of this manual apply to instruments with the serial number prefix(es) listed under SERIAL NUMBERS on the title page.

Manual Updates. An instrument manufactured after the printing of this manual may have a serial prefix that is not listed on the title page. An unlisted serial prefix number indicates that the instrument differs in some way from those documented in this manual.

A "MANUAL UPDATES" packet is shipped with the manual when necessary to provide you with the most current information available at the time of shipment. These packets consist of replacement and addition pages which should be incorporated into the manual to bring it up to date.

Hewlett-Packard offers a Document Update Service that will provide you with further updates as they become available.

If you operate or service instruments of different serial prefixes, we strongly recommend that you join this service immediately to ensure that your manual is kept current. For more information, refer to the Documentation Update Service reply card included with this manual or contact:

Technical Writing Department
Spokane Division
Hewlett-Packard Company
East 24001 Mission - TAF C-34
Spokane, Washington, U.S.A. 99220
Telephone (509) 922-4001

1-5. DESCRIPTION

The HP 8663A is a precision synthesized, signal generator with the following features:

- 100 kHz to 2560 MHz frequency range
- 0.1 Hz resolution (0.2 Hz from 640 to 1280 MHz) (0.4 Hz from 1280 to 2560 MHz)
- 5×10^{-10} /day frequency stability
- +16 to -129.9 dBm output level range (with overrange to +19.9 dBm)
- ± 1 dB level accuracy
- AM, FM, PM, PULSE, and BPSK modulation modes
- Hewlett-Packard Interface Bus (HP-IB) capability

... with exceptional spectral purity.

- SSB phase noise < -131 dBc/Hz at 10 kHz offset from carrier ($320 < f_c < 640$ MHz)
- Broadband noise floor < -146 dBc
- Spurious signals from -78 to -100 dBc depending on f_c
- Harmonics -30 dBc (< -25 dBc, $1280 < f_c < 2560$ MHz)

... microprocessor control for measurement efficiency.

- Keyboard control of all functions
- Storage and recall of front panel settings
- Learn modes
- Stepping of all value-selectable parameters

... and versatile digital sweep.

- Synthesized frequency accuracy and resolution
- Start/Stop and Span modes
- Linear or log RF and modulation sweep
- Selectable time per step
- Completely variable step size
- 5 digital markers

1-6. OPTIONS**1-7. Electrical Options**

Option 001 provides the RF OUTPUT connector and the AM IN, FM IN, and Φ M IN connectors on the rear panel instead of on the front panel.

Option 002 provides the Signal Generator with phase modulation capabilities. This option also allows BPSK to be used at all RF frequency settings.

Option 003 provides guaranteed absolute single-sideband phase noise performance from the 640 MHz output. This output is available only on instruments with serial prefixes 2411A and above.

Option 900 provides an ac power cable (HP part number 8120-1351) for use in the United Kingdom, Cyprus, Nigeria, Rhodesia, or Singapore. Refer to Table 2-2 for description.

Option 901 provides an ac power cable (HP part number 8120-1369) for use in Australia or New Zealand. Refer to Table 2-2 for description.

Option 902 provides an ac power cable (HP part number 8120-1689) for use in Eastern and Western Europe, Saudi Arabia, Egypt. Refer to Table 2-2 for description.

Option 903 provides an ac power cable (HP part number 8120-1378) for use in the United States or Canada. Refer to Table 2-2 for description.

Option 906 provides an ac power cable (HP part number 8120-2104) for use in Switzerland. Refer to Table 2-2 for description.

Option 912 provides an ac power cable (HP part number 8120-2956) for use in Denmark. Refer to Table 2-2 for description.

Option 917 provides an ac power cable (HP part number 8120-4211) for use in South Africa and India. Refer to Table 2-2 for description.

1-8. Mechanical Options (Serial Prefixes 2234A to 2513A)

The following kits might have been ordered and received with the Signal Generator (they are shown in Figure 1-2). If they were not received with the original shipment and are now required, they may be ordered from your nearest Hewlett-Packard office, using the part numbers included in each of the following paragraphs.

Front Handle Kit, Option 907. This kit contains front handles and mounting hardware. Order HP part number 5061-0090 for the basic kit and 2190-0048 for lockwashers (8 required).

Rack Mount Kit, Option 908. This kit contains flanges and hardware for mounting the Generator in a standard rack of 482.5 mm (19 inches). Order HP part number 5061-0078.

Rack Mount Kit with Front Handles, Option 909. This kit contains flanges, handles and mounting hardware (the flanges are different than the Option 908 flanges). Order HP part number 5061-0084 for the basic kit and 2190-0009 for lockwashers (8 required).

1-8. Mechanical Options (Serial Prefixes 2516A and Above)

The following kits might have been ordered and received with the Signal Generator (they are shown in Figure 1-2). If they were not received with the original shipment and are now required, they may be ordered from your nearest Hewlett-Packard office, using the part numbers included in each of the following paragraphs.

Front Handle Kit, Option 907. This kit contains front handles and mounting hardware. Order HP part number 5061-9690 for the basic kit and 2190-0048 for lockwashers (8 required).

Rack Mount Kit, Option 908. This kit contains flanges and hardware for mounting the Generator in a standard rack of 482.5 mm (19 inches). Order HP part number 5061-9678.

Rack Mount Kit with Front Handles, Option 909. This kit contains flanges, handles and mounting hardware (the flanges are different than the Option 908 flanges). Order HP part number 5061-9684 for the basic kit and 2190-0009 for lockwashers (8 required).

1-9. HEWLETT-PACKARD INTERFACE BUS



1-10. Compatibility

The signal generator has an HP-IB interface and can be used with any HP-IB controller or computer for

automatic system applications. The signal generator is fully programmable via the Hewlett-Packard interface Bus. HP-IB is Hewlett-Packard's implementation of IEEE Standard 488 and the identical ANSI Standard MC1.1. The generator's compatibility with HP-IB is defined by the following list of interface functions: SH1, AH1, T6, TE0, L3, LE0, SR1, RL1, PP0, DC1, DT1, and C0. For more detailed information, refer to Section III of this manual.

1-11. HP-IB Address

Two thumbwheel switches inside the top cover select the address code. This procedure is described in paragraph 2-7, and is intended for service-trained persons only. However, the decimal equivalent of the five-bit address code can be displayed on the front panel by selecting Special Function 82 (refer to the detailed operating instruction entitled "HP-IB Address Display").

1-12. ACCESSORIES SUPPLIED

The accessories supplied with the signal generator are shown in Figure 1-1. The power cable is selected at the factory according to the voltage available in the country of destination. For the part numbers of the power cable refer to the paragraph titled Power Cables. For generators shipped to countries using 115 volts, a set of fuses for 230 volt operation is also supplied.

1-13. EQUIPMENT AVAILABLE

A service accessory kit, HP 11714A, is required for servicing and troubleshooting the signal generator. The service kit contains extender boards, connectors, cables, adapters and other service aids. For more details on the service accessory kit, refer to Table 1-5.

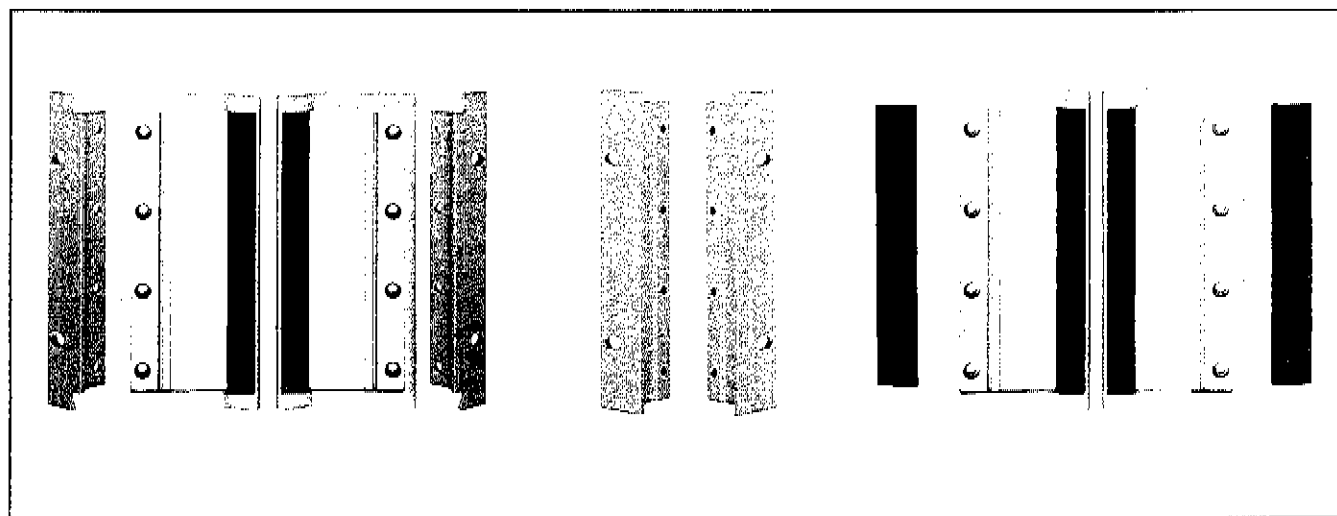

Figure 1-2. Rack Mounting Options

1-14. RECOMMENDED TEST EQUIPMENT

Table 1-4 lists the equipment required for maintaining the generator. The "Critical Specification" column describes the essential requirements for each piece of test equipment. Other equipment can be substituted if it meets or exceeds these critical specifications.

The "Recommended Model" column may suggest more than one model. The first model shown is usually the least expensive, single-purpose model. Alternate

models are suggested for additional features that would make them a better choice in some applications. For example, reasons for recommending an alternate model might be:

- HP-IB programmability

—or—

- Multi-function capability (that is, one model can replace two or more single-purpose models)

old

Table 1-1. Specifications (1 of 4)

Electrical Characteristics	Performance Limits	Conditions
FREQUENCY		
Range	100 kHz to 2560 MHz 2559.999996 MHz	
Resolution	0.1 Hz 0.2 Hz 0.4 Hz	100 kHz to 640 MHz 640 MHz to 1280 MHz 1280 MHz to 2560 MHz
Accuracy and Stability	Same as reference oscillator	
Internal Reference Oscillator: ¹		
Frequency	10 MHz	
Aging Rate	$5 \times 10^{-10}/\text{day}$	After ten day warm-up (typically 24 hours in normal operating environment)
SPECTRAL PURITY		
Residual SSB Phase Noise in 1 Hz Bandwidth	-100 dBc -112 dBc -121 dBc -131 dBc -132 dBc	$320 \leq f_c \leq 640$ MHz 10 Hz offset from carrier 100 Hz offset from carrier 1000 Hz offset from carrier 10 kHz offset from carrier 100 kHz offset from carrier
SSB Broadband Noise Floor in 1 Hz Bandwidth, 3 MHz offset from carrier	<145 dBc	$\geq +10$ dBm output level; 120 to 640 MHz, ϕ M off
Spurious Output Signals (subharmonically related ²)	None <-70 dBc <-40 dBc	0.1 to 640 MHz 640 to 1280 MHz 1280 to 2560 MHz
Spurious Output Signals (nonharmonically related)	<-90 dBc <-100 dBc <-96 dBc <-90 dBc <-84 dBc <-78 dBc	0.1 to 120 MHz 120 to 160 MHz 160 to 320 MHz 320 to 640 MHz 640 to 1280 MHz 1280 to 2560 MHz
NOTE: In the remote mode it is possible to have microprocessor clock related spurious signals spaced 3 MHz apart at levels typically <-80 dBc.		
Spurious Output Signals [Power line (60 Hz) related or microphonically generated (within 300 Hz from carrier)]	<-90 dBc <-85 dBc <-80 dBc <-75 dBc <-70 dBc <-65 dBc	0.1 to 120 MHz 120 to 160 MHz 160 to 320 MHz 320 to 640 MHz 640 to 1280 MHz 1280 to 2560 MHz
NOTE: At 50 Hz line frequency, power line or microphonically related spurious signals may be up to 3 dB higher and appear at offsets as high as 1 kHz from the carrier.		
Harmonics	<-30 dBc $\leq +13$ dBm output <-25 dBc, +13 dBm to +16 dBm output <-25 dBc	0.1 to 1280 MHz 1280 to 2560 MHz
¹ The internal reference oscillator is kept at operating temperature in STANDBY mode with the instrument connected to Mains power.		
² Subharmonically related signals are 1/2, 3/2, etc.		

Table 1-1. Specifications (2 of 4)

Electrical Characteristics	Performance Limits	Conditions
OUTPUT (+15 to +45 degrees C) Range Resolution Absolute Level Accuracy ^{3,4} Flatness Flatness in Sweep Mode (Uncorrected) ⁴	+16 to -129.9 dBm (1.41V to 0.072 μ V into 50 ohms) 0.1 dB < \pm 1.0 dB < \pm 3.0 dB Same as Absolute Level Accuracy < \pm 1.1 dB < \pm 1.5 dB	 +16 to -119.9 dBm -120 dBm and below 0.1 MHz to 1280 MHz 0.1 MHz to 2560 MHz
AMPLITUDE MODULATION Depth Resolution Incidental PM AM Indicator Accuracy AM Rates: Internal AM External Bandwidth (1 dB) Depth 90%, DC Offset < 10 mV AM Distortion (400 Hz and 1 kHz rates)	0 to 95% 0.1% <0.15 radians peak <0.10 radians peak <0.33 radians peak \pm (6% of setting +1% AM) 10 Hz to 10 kHz dc to 1.5 kHz dc to 5 kHz dc to 10 kHz <2% <3% <4%	Output level \leq +10 dBm and below. ⁵ 0 to 95% AM 0.15 to 640 MHz; 30% AM (1 kHz rate) 640 to 1280 MHz; 30% AM (1 kHz rate) 1280 to 2560 MHz; 30% AM (1 kHz rate) Depth \leq 90% AM; for 400 Hz and 1 kHz AM rates 0.15 to 1 MHz 1 to 10 MHz 10 to 2560 MHz 0 to 30% AM 30 to 70% AM 70 to 90% AM
FREQUENCY MODULATION FM Rates: Internal External ac External dc Maximum Peak Deviation (external ac and internal)	10 Hz to 100 kHz 20 Hz to 100 kHz dc to 100 kHz The smaller of 100 kHz or $f_{mod} \times 500$ The smaller of 25 kHz or $f_{mod} \times 125$ The smaller of 50 kHz or $f_{mod} \times 250$ The smaller of 100 kHz or $f_{mod} \times 500$ The smaller of 200 kHz or $f_{mod} \times 1000$ The smaller of 400 kHz or $f_{mod} \times 2000$	1 dB bandwidth 1 dB bandwidth 0.01 to 120 MHz 120 to 160 MHz 160 to 320 MHz 320 to 640 MHz 640 to 1280 MHz 1280 to 2560 MHz
³ Includes flatness, attenuator error, detector error and measurement uncertainty. ⁴ The 8663A uses a microprocessor level accuracy enhancement routine to achieve \pm 1 dB absolute level accuracy and flatness for levels between +16 dBm and -119 dBm. This enhancement can be disabled with a special function. ⁵ AM is possible with an output level \geq \pm 10 dBm, however, its modulation characteristics are not specified.		

Table 1-1. Specifications (3 of 4)

Electrical Characteristics	Performance Limits	Conditions
FREQUENCY MODULATION (Cont'd)		
Maximum Peak Deviation (external dc)	100 kHz 25 kHz 50 kHz 100 kHz 200 kHz 400 kHz	0.01 to 120 MHz 120 to 160 MHz 160 to 320 MHz 320 to 640 MHz 640 to 1280 MHz 1280 to 2560 MHz
Indicated FM Accuracy	±7% of reading (+10 Hz)	50 Hz to 20 kHz rates
FM Deviation Resolution Deviation ≤ 100 kHz	0.1 kHz 0.2 kHz 0.4 kHz	$0.1 \leq f_c \leq 640$ MHz $640 \leq f_c \leq 1280$ MHz $1280 \leq f_c \leq 2560$ MHz
Deviation > 100 kHz	N/A 1 kHz 1 kHz	$0.1 \leq f_c < 640$ MHz $640 \leq f_c < 1280$ MHz $1280 \leq f_c < 2560$ MHz
PHASE MODULATION		
Maximum Peak Phase Deviation	100 deg 25 deg 50 deg 100 deg 200 deg 400 deg	0.1 to 120 MHz 120 to 160 MHz 160 to 320 MHz 320 to 640 MHz 640 to 1280 MHz 1280 to 2560 MHz
Resolution	1 deg 2 deg 4 deg	0.1 to 640 MHz 640 to 1280 MHz 1280 to 2560 MHz
PM Indicator Accuracy	±(12% of setting +3% of full scale)	+15°C to +35°C
Maximum Phase Modulation Rates 50Ω Input Impedance	10 kHz 100 kHz 2 MHz 5 MHz 10 MHz	$0.15 \text{ MHz} \leq f_c < 10 \text{ MHz}$ $10 \text{ MHz} \leq f_c < 50 \text{ MHz}$ $50 \text{ MHz} \leq f_c < 220 \text{ MHz}$ $220 \text{ MHz} \leq f_c < 640 \text{ MHz}$ $640 \text{ MHz} \leq f_c < 2560 \text{ MHz}$
600Ω Input Impedance	10 kHz 100 kHz 2 MHz	$0.15 \text{ MHz} \leq f_c < 10 \text{ MHz}$ $10 \text{ MHz} \leq f_c < 50 \text{ MHz}$ $50 \text{ MHz} \leq f_c < 2560 \text{ MHz}$
Distortion	10%	
PULSE MODULATION⁶		
On/Off Ratio	>85 dB >80 dB	$f_c \geq 640$ MHz $50 \text{ MHz} < f_c < 640 \text{ MHz}$
Rise and Fall Time (10% to 90%)	<250 ns <800 ns <100 ns	$50 \text{ MHz} \leq f_c < 120 \text{ MHz}$ $120 \text{ MHz} \leq f_c < 640 \text{ MHz}$ $f_c \geq 640 \text{ MHz}$
Pulse Repetition Frequency	10 Hz to 99.9 kHz (50% duty cycle) 10 Hz to 2 MHz 10 Hz to 5 MHz	Internal External, $50 \text{ MHz} \leq f_c < 640 \text{ MHz}$ External, $f_c \geq 640 \text{ MHz}$
Minimum Pulse Width	1 μs	Duty cycle <50%
⁶ Pulse modulation is available for RF frequencies below 50 MHz but is not specified.		

Table 1-1. Specifications (4 of 4)

Electrical Characteristics	Performance Limits	Conditions
BINARY PHASE SHIFT KEYING⁷ Carrier Null, 100 kHz Square Wave	>20 dB >17 dB	$120 \text{ MHz} \leq f_o < 640 \text{ MHz}$ $f_o \geq 640 \text{ MHz}$ (Option 002 only, +15°C to +35°C)
INTERNAL MODULATION SYNTHESIZER Frequency Range Frequency Resolution Frequency Accuracy	10 Hz to 99.9 kHz 3 digits Same as reference oscillator.	
GENERAL Operating Temperature Range Power Requirements: Line Voltage 115V Setting 230V Setting Line Frequency Power Dissipation Electromagnetic Interference (EMI)	0 to +55°C 90 to 126V 198 to 252V 48 to 66 Hz 450 VA maximum MIL STD 461A and VDE 0871	Conducted and radiated interference is within the requirements of methods CE03 and RE02 of MIL STD 461A as well as VDE 0871.
Net Weight Shipping Weight Dimensions ⁸ : Height Width Depth	33.8 kg (74 lbs) 40 kg (88 lbs) 178 mm (7.0 in.) nominal 425 mm (16.75 in.) nominal 642 mm (25.3 in.) nominal	Depth includes front-panel depth of 45 mm (1.75 in.)
⁷ BPSK is standard for RF frequencies up to 640 MHz. With Option 002, BPSK is available at all RF frequencies. For RF frequencies up to 640 MHz, standard BPSK modulation is available at rates above 100 kHz, but is unspecified. BPSK cannot be simultaneously selected with Option 002 phase modulation at 640 MHz and above or with pulse modulation.		
⁸ Dimensions are for general information only. If dimensions are required for building special enclosures, contact your HP office.		

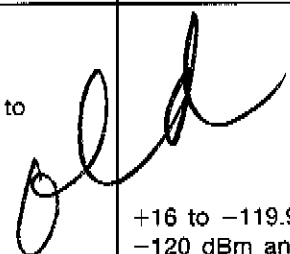
Table 1-2. Supplemental Characteristics

Supplemental characteristics are typical, but nonwarranted performance parameters. They are only intended to provide information which can be useful in determining instrument application.

FREQUENCY

Internal: The internal reference oscillator accuracy is a function of time base calibration \pm aging rate \pm temperature effects \pm line voltage effects. Temperature and line voltage effects are typically $<3.5 \times 10^{-11}/^{\circ}\text{C}$ and $<1 \times 10^{-10}/\pm 10\%$ line voltage change.

External: Any 5 MHz ($\pm 0.005\%$) frequency standard at a level of $1 V_{\text{rms}} \pm 0.1$ volt or any 10 MHz ($\pm 0.005\%$) standard at a level of 0.5 to 0.7 V_{rms} into 50 Ω (rear-panel connector).

Reference Output (Source Impedance 65 Ω): Reference signal (INT or EXT) available from rear-panel connector at a level of $>0.5 V_{\text{rms}}$ into 50 Ω . (Output is always 10 MHz even with 5 MHz external reference frequency.)

Frequency Switching Speed:¹ Total switching time depends on the programming mode used. The 8663A RF settling time is 250 μs , to be within 1 kHz and 400 μs to be within 100 Hz. The table below gives typical total switching time to be within 100 Hz. (All data for 11 digits of frequency change.)

Programming Mode	Microprocessor Time	Settling Time	Total Switching Time
String	12.1 ms	400 μs	12.5 ms
Character	8.3 ms	400 μs	8.7 ms
Remote Sweep	In these modes, micro-processor time and RF time overlap.		700 μs
Fast Learn			510 μs
Frequency Hop	130 μs	400 μs	530 μs

OUTPUT

Impedance: 50 Ω nominal.

SWR: <1.5

Level Switching Time: 60 ms from last command statement to stable output.

AMPLITUDE MODULATION

External Input Impedance: 600 Ω

External Input Level Required for Calibrated Operation: 1V peak. Front panel, Input-level annunciator indicates 1V peak $\pm 2\%$.

FREQUENCY MODULATION
Measured Center Frequency Stability in DC Mode

f_c (MHz)	Center Frequency Accuracy	Measured Center Frequency Stability
0.01-120	± 10 kHz	± 200 Hz/hr
120-160	± 2.5 kHz	± 40 Hz/hr
160-320	± 5 kHz	± 100 Hz/hr
320-640	± 10 kHz	± 200 Hz/hr
640-1280	± 20 kHz	± 400 Hz/hr
1280-2560	± 40 kHz	± 800 Hz/hr

Input Impedance (Front Panel Input): 600 Ω nominal.

External Input Level Required for Calibrated Operation: 1V peak. Front panel, input-level annunciator indicates 1V peak $\pm 2\%$. (When greater accuracy is required, voltage of modulating signal should be monitored externally.)

NOTE

The EXTERNAL SOURCE annunciators will not provide a reliable indication if modulation rate is <20 Hz or if the Generator is sweeping with Time/Step ≤ 10 ms.

Auxiliary FM Input: Rear-panel connector for FM modulation. Operates independently allowing simultaneous FM modulation with two tones. Input impedance: 5.1 k Ω ; 4V peak yields maximum allowable deviation.

PULSE MODULATION

Pulse Delay Time: <150 ns

External Input Impedance: 50 Ω dc-coupled

External Input Level Required: $>2.5\text{V}$ —On, $<0.5\text{V}$ —Off (not to exceed $\pm 10\text{V}$).

BINARY PHASE SHIFT KEYING

External Input Impedance: 50 Ω , dc-coupled

External Input Level Required: $>2.5\text{V}$ —On, $<0.5\text{V}$ —Off (not to exceed $\pm 10\text{V}$).

PHASE MODULATION

External Input Impedance: 50 Ω , 600 Ω selected with a special function. Ac or dc coupling.

Low Frequency ac Coupling Limit: 200 Hz, 50 Ω
20 Hz, 600 Ω

External Input level Required for Calibrated Operation:
50 Ω input: 1V peak from source with SWR $<1.21 : 1$
600 Ω input: 1V peak. (Front panel MOD LEVEL annunciator indicates calibrated level $\pm 5\%$ for rates ≤ 100 kHz)

INTERNAL MODULATION SYNTHESIZER

Output Level: 1V peak into 600 Ω , available at rear panel.

Output Impedance: 600 Ω

Flatness: $<\pm 1\%$ referenced to 1 kHz

Distortion: $<1\%$

¹ Due to bandwidth switching of the automatic internal leveling loop, brief level inaccuracies (i.e., typically <30 ms) may occur when switching through exactly 150 kHz and exactly 1 MHz RF output frequencies.

Table 1-3. Features (1 of 2)

Electrical Characteristics	Description
DIGITAL SWEEP	
Start-Stop Sweep	Sweeps between two selected RF or modulation frequencies.
Span Sweep	Symmetrical sweep about center RF or modulation frequency selected.
Sweep Width	Determined by frequency resolution and frequency range of instrument.
Step Size	Choice of 100 or 1000 steps per sweep, or set to any value within the frequency resolution of the instrument.
Sweep Speed	Five selectable speeds: 0.5 ms, 1 ms, 2 ms, 10 ms, and 100 ms per step (0.5 ms is nominal value which will vary depending on use of markers or log sweep).
Log Sweep	Two choices available in increasing steps of 10% or 1% of the last frequency.
Frequency Markers	Five digital markers. Resolution and accuracy same as RF output. (Not available in modulation sweep.)
Intensity Markers	Z-axis modulation of CRT display.
Amplitude Markers	Rear panel signal (5 kHz triangle wave) can be applied to AM input connector to provide adjustable amplitude markers.
Marker Sweep	Start/stop sweeps between any two frequency markers can be selected.
Display Blanking	250 μ s positive pulse (TTL levels) available at rear panel for display blanking during frequency switching.
Sweep Output	0 to 10V (nominal) staircase ramp. 0V at start of sweep; approximately +10V at end of sweep regardless of sweep width. 10,000 points maximum.
SWEEP MODE	
Auto	Sweep repeats automatically.
Single	Single sweep activated by front-panel keyboard.
Manual	Sweep controlled by front-panel knob.
REMOTE OPERATIONS	
HP-IB (IEEE 488 Capability:	
Interface	Hewlett-Packard Interface Bus (HP-IB). HP-IB is Hewlett-Packard's implementation of IEEE Standard 488 (and identical ANSI Standard MC1.1). The generator's compatibility with HP-IB is defined by the following list of interface functions: SH1, AH1, T6, TE0, L3, LE0, SR1, RL1, PP0, DC1, DT1 and C0.
Functions Controlled	All functions controlled from the front panel, with the exception of the power switch, are programmable with the same accuracy and resolution as in manual mode.
Auxiliary Control:	
Interface	Rear panel 14-pin Micro Ribbon connector
Functions Controlled	Step Up/Step Down: Same as INCREMENT keys on keyboard.
	Stop Sweep: Puts sweep in manual mode.
	Continue Sweep: Puts sweep in auto mode.
	Single Sweep: Initiates single sweep.
	Sequence: Same as sequence key on keyboard.
	Input Required: Contact closure to ground or 5 μ s negative-true TTL pulse. Internally installed jumper determines mode.

Table 1-3. Features (2 of 2)

Electrical Characteristics	Description
REMOTE OPERATIONS (Cont'd) Auxiliary Control: Functions Controlled (Cont'd)	Outputs: 5 μ s negative-true TTL pulse output under following conditions: <ol style="list-style-type: none">1. Change in signal parameter; for example, frequency, amplitude, modulation,2. End of sweep.3. Pen Up/Down (in single sweep mode only). When Special Function 91 is enabled, the Auxiliary connector inputs will recall Register 1-9 contents (Frequency Hop).

old

Table 1-4. Recommended Test Equipment (1 of 2)

Instrument	Critical Specification	Recommended Model	Use*
Amplifier, Low Noise	Input/Output Impedance: 50 ohms Frequency Bandwidth: 1 kHz to 1 MHz Noise Figure: <3 dB Gain: 40 ±1 dB	HP 08640-60506 Requires 19-25 Vdc Power Supply	P
Amplifier, Wideband	Gain: 26 dB Frequency Range: 100 kHz to 1280 MHz Impedance: 50 ohms Connector: Type N	HP 8447D Option 010	P
Analyzer, Audio	Frequency Range: 20 Hz to 100 kHz Minimum Distortion Measurement: <0.1% Audio Source Output Level: >1 V _{rms} Audio Source Distortion: <0.01%	HP 8903B	P, A
Analyzer, Modulation	Accuracy: ±2% of reading AM Rejection: <30 Hz at 50% AM (3 kHz BW) FM Rejection: <0.2% AM (50 kHz FM)	HP 8901A	P, A
Analyzer, Signature	No known substitute. Provides preferred method for troubleshooting digital circuitry.	HP 5005A, HP 5005B HP 5006A	T
Analyzer, Spectrum	Frequency Range: 0.1 to 5600 MHz Resolution Bandwidth: ≤1 kHz	HP 8565A	P, A, T
Analyzer, Spectrum	Frequency Range: 100 Hz to 150 kHz Resolution Bandwidth: ≤10 Hz Tracking Generator Feature (required for one adjustment not generally performed: that is, the AGC Bandwidth Adjustment)	HP 8556A/ HP 8552B/141T	P, A
Attenuator, Fixed	Attenuation: As required by performance test Frequency Range: 10 kHz to 1300 MHz Accuracy: ±0.1 dB SWR: <1.3	HP 8491A	P
Attenuator, 1 dB Steps	Steps: 1 dB from 0 dB to 10 dB Frequency Range: 100 to 300 MHz	HP 355C or HP 8494G with HP 11713A	A
Attenuator, 10 dB Steps	Steps: 10 dB from 0 dB to 50 dB Frequency Range: 100 to 300 MHz	HP 355D or HP 8496G with HP 11713A	A
Cable, RF	Connector: UG-210/U Type N (male)	HP 11500B	P, A
Controller, HP-IB	HP-IB compatibility as defined by IEEE Standard 488-1975 and the identical ANSI Standard MC1.1: SH1, AH1, T2, TE0, L2, LE0, SR0, RL0, PP0, DC0, DT0, and C1, 2, 3, 4, 5.	HP 9826, HP 9836	P, T
Counter, Frequency	Range: 2560 MHz Resolution: 0.1 Hz External Time Base Capability	HP 5328A Option 031 or HP 5328A Opt. 011 & 031	P, A, T
Detector, RF	Frequency Range: 10 to 2600 MHz	HP 8470B	P, A, T
Filter, Low-Pass	Bandwidth: 1 MHz Impedance: 50 ohms	See Figure 1-2	P

*P=Performance A=Adjustments T=Troubleshooting

Table 1-4. Recommended Test Equipment (2 of 2)

Instrument	Critical Specification	Recommended Model	Use*
Function Generator	Level: 1 Vpk minimum into 600 ohms Frequency: 10 kHz Distortion: <0.1%	HP 3325A	P, A
Generator, Pulse	Repetition Rate: 10 Hz to 5 MHz Output Level: TTL compatible Rise/Fall Time: <10 ms	HP 8111A	P
Generator, Signal (Reference for Optional SSB Phase Noise Test)	Frequency: .01 to 2560 MHz Output: -50 dBm SSB Phase Noise: same or better than the specification for the Generator under test.	HP 8663A	P, A
Generator, Tracking	Frequency Range: 10 to 1200 MHz Output Level: >0 dBm Compatible with HP 8565A Spectrum Analyzer	HP 8444A Option 059	A
Kit, Service Accessory	Required for servicing and troubleshooting. See Table 1-4 for parts listing and description.	HP 11714A	A, T
Mixer	Frequency: 0.2 to 500 MHz Type: Double Balanced	HP 10514A	P
Mixer	Frequency: 500 to 2560 MHz Type: Double Balanced	Watkins-Johnson M1J	P
Oscillator, Sweep	Frequency Range: 10 to 2000 MHz Output Level: >+3 dBm Capable of generating markers	HP 8350A/ HP 83522A	A
Oscilloscope	Vertical Sensitivity: 10 mV/division Bandwidth: 50 MHz	HP 1741A	P, A, T
Power Meter and Sensor	Frequency Range: 250 kHz to 1300 MHz Power Range: +17 to -60 dBm Accuracy: ± 0.2 dB	HP 436A with 8482A & 8484A or HP 436A, Opt. 022 with 8482A & 8484A	P, A
Power Supply, dc	Range: 0 to 25 Vdc Current: 500 mA	HP 6002A Opt. 001	A, T
Standard, Frequency	Frequency: 10 MHz Long Term Stability: $<1 \times 10^{-10}/24$ hr	HP 5065A	P, A
Voltmeter, Digital (DVM)	Accuracy: 4½ digit, $\pm 0.05\%$ of reading ± 1 digit Range: 10 mV to 600V Sensitivity: 10 μ V	HP 3478A	P, A, T
*P=Performance A=Adjustments T=Troubleshooting			

Table 1-5. 11714A Service Accessory Kit

Item Number	HP Part Number	CD	Qty	Description
1	08662-60276	0	3	Extender Board (15 pins)
2	08662-60275	9	3	Extender Board (18 pins)
3	08662-60277	1	3	Extender Board (10 pins)
4	08662-60274	8	3	Extender Board DCU (2 x 18 pins)
5	08662-60271	5	1	Extender Board Power Supply (10 and 15 pins)
6	08662-60273	7	1	Extender Board Power Supply (22 pins)
7	08662-60075	7	3	Test Cable (SMC to BNC)
8	08662-60080	4	4	Extender Cable
9	1251-1631	9	1	Test Data Bus Connector
10	1250-1598	5	3	RF Test Probe (AC Coupled)
11	1250-0827	1	1	SMC Adapter (Straight)
12	1250-0838	4	2	SMC Adapter (Tee)
13	08662-60196	3	1	Mixer Test Board
14	1250-0832	8	2	Adapter (BNC to SMC)
15	1250-0839	5	2	RF Termination
16	08662-60272	6	1	Extender Board Power Supply (18 pins)
17	5060-6033	4	1	Extender Board A8 Assembly (15 pins)
Not Shown	08662-10001	4	1	Verification Tape (8662A Only)
Not Shown	08662-90057	8	1	Operating Note
Not Shown	10811-90002	9	1	Operating and Service Manual
Not Shown	08663-60347	7	1	2 x 24 Extender Board Assembly

Handwritten signature

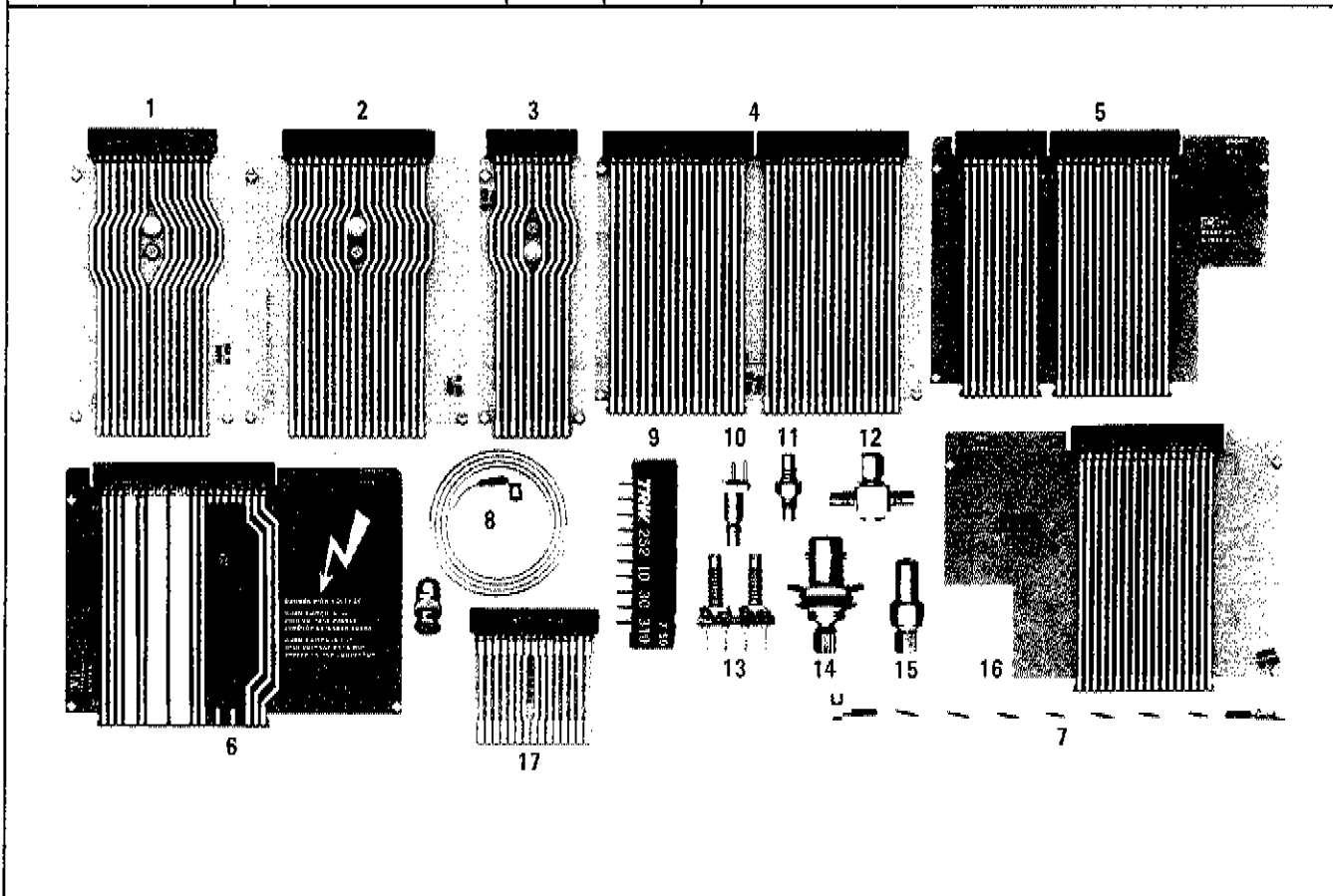

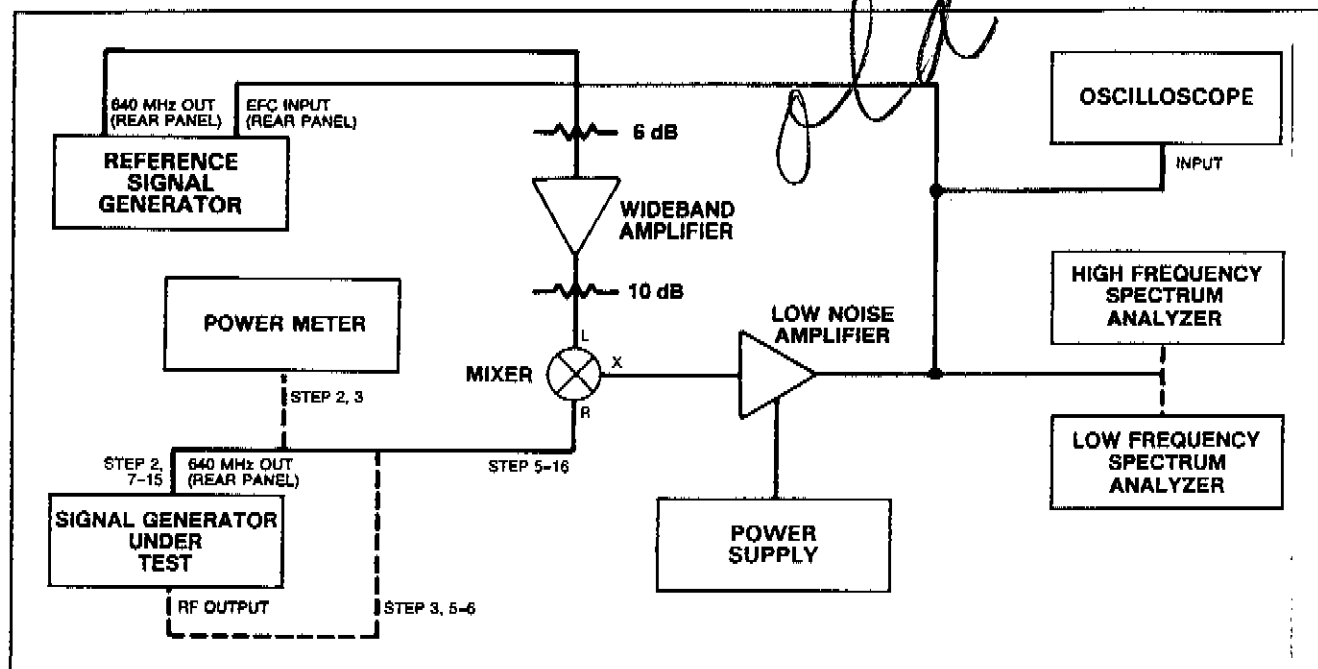

Figure 4-14. Absolute SSB Phase Noise of rear Panel 640 MHz Output (Option 003 Only) Test Setup

Equipment

Mixer.....	Watkins-Johnson M1J
Low Noise Amplifier	HP 08640-60506 (with HP 6002A power supply)
Oscilloscope	HP 1741A
Spectrum Analyzer (Low frequency)	HP 3582A
Spectrum Analyzer (High frequency)	HP 8566A or HP 8568B
Signal Generator (Reference).....	HP 8662A Option 003
Wide Band Amplifier	HP 8447E
Attenuators, Coaxial Fixed	HP 8491A series
Power Meter	HP 436A with HP 8481A Power Sensor

Procedure

1. Connect the equipment as shown in Figure 4-14. Both the Reference Signal Generator and Signal Generator Under Test must have their Reference Oscillator switches set to INT. The signal level into the L input of the mixer should be in the range, +7 to +10 dBm. Change the value of the pads, if necessary, to obtain this output level.
2. Use the power meter to measure the RF level of the rear panel 640 MHz output signal of the Signal Generator Under Test. The level must be greater than +1.0 dBm. Record the measured level.
 Rear panel 640 MHz output level _____ dBm
3. Connect the power meter to the main RF output of the Signal Generator Under Test. Set the frequency of the generator to 640.0 MHz and set the amplitude to whatever setting gives the closest power meter reading to the value measured in step 2, above.
4. Set the Amplitude increment value of the Signal Generator Under Test to 50 dB. Press the Increment down arrow key thus reducing the amplitude by 50 dB.

Calibration

NOTE

This calibration must be performed once with the high frequency spectrum analyzer and twice with the low frequency spectrum analyzer. Thus, there are three values specified for every frequency setting in steps 5 and 6. Use the first setting given with the high frequency spectrum analyzer and the other values (in parenthesis and brackets) with the low frequency spectrum analyzer.

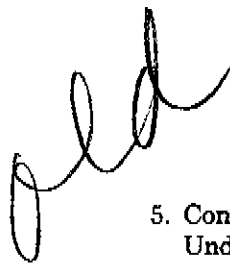
- 
5. Connect a cable from the RF port of the mixer to the RF output connector of the Signal Generator Under Test. Set the output frequency of this generator to 640.01 (640.000 1) [640.000 01] MHz. This will produce a 10 kHz (100 Hz) [10 Hz] signal out of the mixer which is used to calibrate the spectrum analyzer.
 6. Tune the spectrum analyzer to 10 kHz (100 Hz) [10 Hz] and set the reference level of the spectrum analyzer to the level of the signal at 10 kHz (100 Hz) [10 Hz].

Set Quadrature

7. Connect a cable from the RF port of the mixer to the rear panel 640 MHz output of the Signal Generator Under Test.
 8. Set the oscilloscope to dc coupled input and 0.1 volts/ division vertical resolution. Set sweep speed to 0.2 mSEC/ division although sweep speed will not affect the measurement. Adjust the vertical position control so ground level is at the center line of the display.
 9. The signal displayed on the oscilloscope should be a slowly varying signal. If the signal is a dc level, adjust the FINE FREQUENCY ADJUST on the rear panel of the Reference Signal Generator until the signal begins to vary. If necessary, change the vertical resolution so the oscilloscope displays the peaks of the waveform. Note the peak amplitude (Vp) of the signal and record here.
- Vp _____
10. Slowly adjust the FINE FREQUENCY ADJUST on the rear panel of the Reference Signal Generator while watching the oscilloscope display. Turn the adjustment in the direction which decreases the rate of change of the signal. Continue the adjustment until the signal becomes a dc level which indicates the signal generators are phase locked together. The dc level of the signal (+ or -) must be less than 30% of Vp measured in step 9.

NOTE

This is a very difficult adjustment to make. It is very easy to overshoot the point where the signal becomes dc in which case the rate of change will begin to increase. It is best to let both signal generators set with the line cords connected for at least 24 hours and with the LINE switch to ON for 1 hour before making this measurement. Once set the dc level should be stable for at least 15 minutes which is long enough to make the measurement. If the dc level drifts too much, the problem could be that the reference oscillator does not meet its long term stability specification. Perform the Internal Time Base Aging Test to check its stability.

Measurement

11. Set the spectrum analyzer to its noise measurement mode. In this mode the spectrum analyzer normalizes the measurement to a 1 Hz bandwidth and corrects the reading to compensate for the noise measurement properties of the analyzer.

12. Set the spectrum analyzer center frequency to the offset at which phase noise is to be measured. This is 10.0 kHz the first time through this procedure. Lower the video bandwidth or use trace averaging to reduce the ambiguity of reading the noise level. Also if there is a spurious signal at exactly 10.0 kHz, read the noise level on either side of the signal. Determine how far (-XX dB) the noise level is below the reference level. If the spectrum analyzer gives a marker level in absolute dBm, subtract the reference level from it to get the relative value. Record the value in the table that follows.
13. The following corrections must be applied to the value just measured to get the actual phase noise:
 - Add -50 dB because the reference level was calibrated with a signal 50 dB lower than the actual 640 MHz output.
 - Add -6 dB because the measured value is the double sideband value and the specification is the single sideband value.
 - Add -3 dB because the reference signal adds an equal amount of noise to the measured value.

Thus, the total correction is -59 dB.
14. Measure the phase noise at offsets of 100 kHz and 1 MHz with the high frequency spectrum analyzer. Follow the instructions in steps 12 and 13. Record the measured values in the table that follows.
15. Replace the high frequency spectrum analyzer with the low frequency spectrum analyzer. The test set-up must be calibrated twice with the low frequency spectrum analyzer. Return to step 5 and restart the procedure there using the the settings in parenthesis, (). When the Measurement Section is reached, measure the phase noise at offsets of 100 Hz and 1 kHz. Record the measured values in the table that follows.
16. Return to step 5 and restart the procedure there using the settings in brackets, []. When the Measurement Section is reached, measure the phase noise at an offset of 10 Hz. Record the value in the table that follows.

NOTE

The phase noise at 1 Hz from the carrier is not measured by this procedure. The measurement at 10 Hz insures that the noise at 1 Hz is within specifications. The noise at 1 Hz could be measured by using a low-noise amplifier with dc coupling.

Offset	Measured Noise			Limit (dBc/Hz)
	Relative to Reference Level (dB/Hz)	Correction	Total (dBc/Hz)	
10 Hz	_____	-59 dB	_____	- 84
100 Hz	_____	-59 dB	_____	-104
1 kHz	_____	-59 dB	_____	-121
10 kHz	_____	-59 dB	_____	-145
100 kHz	_____	-59 dB	_____	-157
1 MHz	_____	-59 dB	_____	-157

DONE

DOCUMENTATION UPDATE SERVICE PACKET

3

HP 8663A OPERATION AND CALIBRATION MANUAL
(rev.12MAR90)

HP 8663A SYNTHESIZED SIGNAL GENERATOR

Including Options 001, 002, & 003

Operation and Calibration Manual

SERIAL NUMBERS

This manual applies directly to instruments with serial numbers prefixed:

2234A to 2927A and all *MAJOR* changes that apply to your instrument.

rev.20JUL89

For additional important information about serial numbers, refer to "INSTRUMENTS COVERED BY THIS MANUAL" in Section 1.

Second Edition

This material may be reproduced by or for the U.S. Government pursuant to the Copyright License under the clause at DFARS 52.227-7013 (APR 1988).

Copyright©HEWLETT-PACKARD COMPANY 1982
EAST 24001 MISSION AVENUE, TAF C-34, SPOKANE, WASHINGTON, U.S.A. 99220

Operation and Calibration Manual HP Part 08663-90069

Other Documentation Available

Service Manual (Volume 1, 2, 3, 4) HP Part 08663-90071

Microfiche Operation and Calibration Manual HP Part 08663-90070

Microfiche Service Manual HP Part 08663-90072

Printed in U.S.A. : November 1989



**HEWLETT
PACKARD**

Electrical Characteristics	Performance Limits	Conditions
Maximum Peak Deviation (external dc)	100 kHz 25 kHz 50 kHz 100 kHz 200 kHz 400 kHz	0.1 to 120 MHz 120 to 160 MHz 160 to 320 MHz 320 to 640 MHz 640 to 1280 MHz 1280 to 2560 MHz
Indicator Accuracy	$\pm(7\% \text{ of reading} + 10 \text{ Hz})$	50 Hz to 20 kHz rates
FM Resolution	100 Hz 200 Hz 400 Hz	0.1 to 640 MHz 640 to 1280 MHz 1280 to 2560 MHz
Incidental AM (AM sidebands)	-72 dBc	1 kHz rate and 20 kHz deviation 10 to 2560 MHz
FM Distortion	1.00% 1.70%	400 Hz to 1 kHz rates less than 20 kHz rates
Center Frequency Accuracy and Long Term Stability	Same as CW mode	Internal and external mode only.

¹ AM is possible above these output levels but not specified.

(Handwritten signature and date)
 (20 JUL 89)

Description

All AM and FM specifications are checked by measuring the specified parameters on a modulation analyzer. Distortion is checked by measuring the demodulated output from the modulation analyzer.

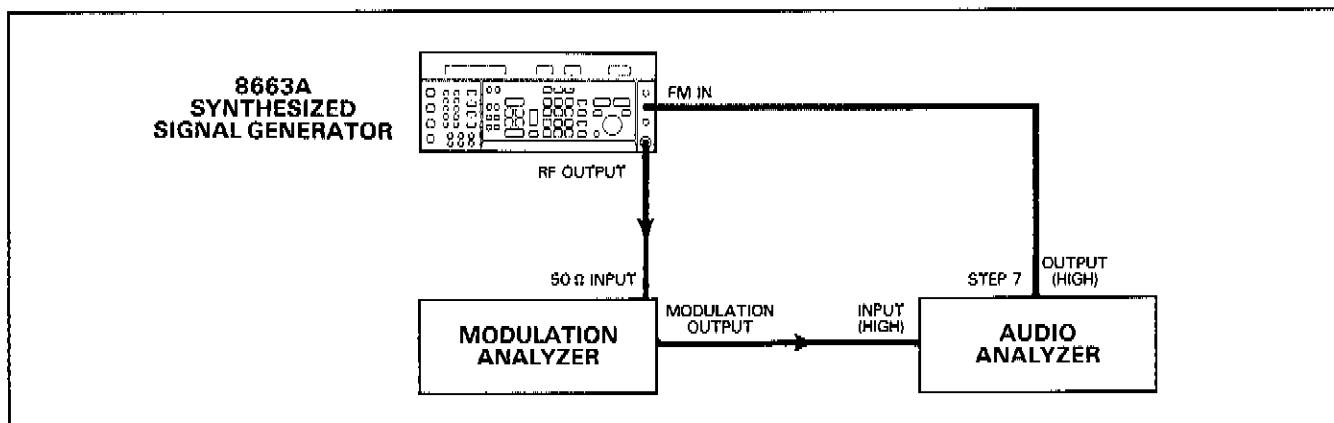

Figure 4-3. AM and FM Test Setup

Equipment

Modulation Analyzer HP 8901A
 Audio Analyzer HP 8903B

old

Procedure

- Connect the instruments as shown in Figure 4-3 and apply power. Set the Generator's output amplitude to +10.0 dBm. Set the Modulation Analyzer as follows:
 HP FILTER 300 Hz
 LP FILTER 15 kHz
 FM DE-EMPHASIS OFF
 DETECTORS PEAK+
 AUTOMATIC OPERATION ON
 MEASUREMENT MODE AM

AM Indicator Accuracy

- Set the Generator to 100.0 MHz, AM with INT 1k source. Set AM% to the values in the first column of the table below. Check that the modulation analyzer's readings are within the specified values given in the table below.

AM Indicated (%) For 100 MHz	Results		
	Min	Actual	Max
10	8.4	_____	11.6
30	27.2	_____	32.8
70	64.8	_____	75.2
90	83.6	_____	96.4

Repeat with the Generator set to 500.0 MHz, 1.0 GHz and 1.3 GHz.

AM Indicated (%) For 500 MHz	Results		
	Min	Actual	Max
10	8.4	_____	11.6
30	27.2	_____	32.8
70	64.8	_____	75.2
90	83.6	_____	96.4

AM Indicated (%) For 1.0 GHz	Results		
	Min	Actual	Max
10	8.4	_____	11.6
30	27.2	_____	32.8
70	64.8	_____	75.2
90	83.6	_____	96.4

AM Indicated (%) For 1.3 GHz	Results		
	Min	Actual	Max
10	8.4	_____	11.6
30	27.2	_____	32.8
70	64.8	_____	75.2
90	83.6	_____	96.4

Re-check accuracy at 100.0 MHz using the Generator's INT 400 source and the Modulation Analyzer's 50 Hz HP filter.

AM Indicated (%) For 100 MHz	Results		
	Min	Actual	Max
10	8.4	_____	11.6
30	27.2	_____	32.8
70	64.8	_____	75.2
90	83.6	_____	96.4

Incidental Φ M

- Set the Generator to 30% AM with INT 1k source and output level of +10 dBm. Use the modulation analyzer's 300 Hz HP filter and 3 kHz LP filter. Set the Generator's frequency and modulation analyzer's mode as stated in the table below. Check for the readings given in the table below.

8663A Frequency	Modulation Analyzer Mode	Results	
		Actual	Max
600.0 MHz	Φ M	_____	0.15 rad
1000.0 MHz	Φ M	_____	0.1 rad

AM Distortion

- Connect a cable from the MODULATION OUTPUT of the modulation analyzer to the input of the distortion analyzer. Set the distortion analyzer to DISTN. Set the Generator to 100.0 MHz. Set the modulation Analyzer to AM. Set the Generator to INT 1k source and the AM depths in the table below. Measure distortion at each setting and compare it to the specified value given in the table.

AM Indicated (%) For 100 MHz	Results	
	Actual	Max
30	_____	2.0%
70	_____	3.0%
90	_____	4.0%

Repeat the distortion measurements at frequency setting of 600.0 MHz, 1.0 GHz, and 1.3 GHz.

AM Indicated (%) For 600 MHz	Results	
	Actual	Max
30	_____	2.0%
70	_____	3.0%
90	_____	4.0%

AM Indicated (%) For 1.0 GHz	Results	
	Actual	Max
30	_____	2.0%
70	_____	3.0%
90	_____	4.0%

old

AM Indicated (%) For 1.3 GHz	Results	
	Actual	Max
30	_____	2.0%
70	_____	3.0%
90	_____	4.0%

FM Indicator Accuracy

- Set the Generator to 100.0 MHz and FM mode with the INT 1kHz source. Set FM deviation to the values in the table below. Set the modulation analyzer to FM mode. Check that the readings are within the specified values given in the table.

FM Indicated	Results		
	Min	Actual	Max
5.0 kHz	4.54 kHz	_____	5.46 kHz
30.0 kHz	27.29 kHz	_____	32.71 kHz
70.0 kHz	63.69 kHz	_____	76.31 kHz
100.0 kHz	90.99 kHz	_____	109.01 kHz

Incidental AM

- Set the Generator to 100.0 MHz, +10 dBm amplitude, and FM modulation off. Set the modulation analyzer to AM mode with 300 Hz high pass filter, 15 kHz low pass filter, and the PEAK+ detector selected. The modulation analyzer's reading must be less than .05% (-72 dBc). If the reading is too high, it means the residual AM of the modulation analyzer (or possibly of the Generator) is too high to make the incidental AM measurement.

Determine the cause of the high residual AM before proceeding. If the reading is less than .05% (-72dBc), set the Generator to FM mode, 20 kHz deviation with internal 1 kHz source and output power at +10 dBm. Set the Generator to the frequency settings in the table below. At each setting measure the incidental AM with the modulation analyzer and check that the reading is less than the value given in the table below.

Frequency Setting For 1.0 GHz	Results	
	Actual	Max
100.0 MHz	_____	.05%
1.0 GHz	_____	.05%
1.3 GHz	_____	.05%

FM Distortion

7. Connect the instruments as shown in Figure 4-3. Set the Generator to 100.0 MHz, 100 kHz FM deviation and EXT AC source. Set the Audio Analyzer's output frequency to 20 kHz. Adjust the output level of the Audio Analyzer for approximately 1.49V or until the EXT MOD HI/LO indicators on the signal generator are extinguished. Set the modulation analyzer to measure FM with all filters off. The measured distortion should be less than 1.0%.

Set the Audio Analyzer's output to 100 kHz. The measured distortion should be less than 1.7%.

8. If the Generator failed any of the previous tests, perform the "AM and FM Adjustments" or "ALC Loop Bandwidth Adjustment" in Section 5 or troubleshoot with the procedures described in Service Sheet BD7.

A large, stylized handwritten signature or set of initials, possibly 'H. H.', is written in the center of the page. The ink is dark and the strokes are fluid and interconnected.

PERFORMANCE TEST 3

PHASE MODULATION TEST (Option 002 only)

old

Specification

Electrical Characteristics	Performance Limits	Conditions
Phase Modulation		
Peak Phase Deviation	100 degrees 25 degrees 50 degrees 100 degrees 200 degrees 400 degrees	0.1 to 120 MHz 120 to 160 MHz 160 to 320 MHz 320 to 640 MHz 640 to 1280 MHz 1280 to 2560 MHz
Resolution	1 degree 2 degrees 4 degrees	0.1 to 640 MHz 640 to 1280 MHz 1280 to 2560 MHz
Indicator Accuracy	$\pm(12\%$ of setting + 3% of full scale)	for rates given below
Rates ¹	10 kHz 100 kHz 2 MHz 5 MHz 10 MHz	0.15 to 10 MHz 10 to 50 MHz 50 to 220 MHz 220 to 640 MHz 640 to 2560 MHz
Distortion	10%	for rates given above
¹ For external DC coupling, For external AC coupling, 600 ohm input, minimum rate is 20 Hz. For external AC coupling, 50 ohm input, minimum rate is 200 Hz. For internal modulation source, minimum rate is 10 Hz.		

Description

Phase modulation specifications are checked by using a modulation analyzer to measure deviation. The demodulated output from the modulation analyzer is measured by an audio analyzer to check distortion. At rates and RF frequencies above the range of the modulation analyzer, a spectrum analyzer is used to check phase deviation accuracy.

3048MS
HP 8663A
SYNTHESIZED SIGNAL GENERATOR
Including Options 001, 002, & 003
Operation and Calibration Manual

SERIAL NUMBERS

This manual applies directly to instruments with serial numbers prefixed:

2234A to 2927A and all *MAJOR* changes that apply to your instrument.

rev.12AUG91

For additional important information about serial numbers, refer to "INSTRUMENTS COVERED BY THIS MANUAL" in Section 1.

Second Edition

This material may be reproduced by or for the U.S. Government pursuant to the Copyright License under the clause at DFARS 52.227-7013 (APR 1988).

Copyright © HEWLETT-PACKARD COMPANY 1982
EAST 24001 MISSION AVENUE, TAF C-34, SPOKANE, WASHINGTON, U.S.A. 99220

Operation and Calibration Manual HP Part 08663-90069

Other Documentation Available

Service Manual (Volume 1, 2, 3, 4) HP Part 08663-90071

Microfiche Operation and Calibration Manual HP Part 08663-90070

Microfiche Service Manual HP Part 08663-90072

Printed in U.S.A. : November 1989



CERTIFICATION

Hewlett-Packard Company certifies that this product met its published specifications at the time of shipment from the factory. Hewlett-Packard further certifies that its calibration measurements are traceable to the United States National Bureau of Standards, to the extent allowed by the Bureau's calibration facility, and to the calibration facilities of other International Standards Organization members.

WARRANTY

This Hewlett-Packard instrument product is warranted against defects in material and workmanship for a period of one year from date of shipment. During the warranty period, Hewlett-Packard Company will at its option, either repair or replace products which prove to be defective.

For warranty service or repair, this product must be returned to a service facility designated by HP. Buyer shall prepay shipping charges to HP and HP shall pay shipping charges to return the product to Buyer. However, Buyer shall pay all shipping charges, duties, and taxes for products returned to HP from another country.

HP warrants that its software and firmware designated by HP for use with an instrument will execute its programming instructions when properly installed on that instrument. HP does not warrant that the operation of the instrument, or software, or firmware will be uninterrupted or error free.

LIMITATION OF WARRANTY

The foregoing warranty shall not apply to defects resulting from improper or inadequate maintenance by Buyer, Buyer-supplied software or interfacing, unauthorized modification or misuse, operation outside of the environmental specifications for the product, or improper site preparation or maintenance.

NO OTHER WARRANTY IS EXPRESSED OR IMPLIED. HP SPECIFICALLY DISCLAIMS THE IMPLIED WARRANTIES OF MERCHANTABILITY AND FITNESS FOR A PARTICULAR PURPOSE.

EXCLUSIVE REMEDIES

THE REMEDIES PROVIDED HEREIN ARE BUYER'S SOLE AND EXCLUSIVE REMEDIES. HP SHALL NOT BE LIABLE FOR ANY DIRECT, INDIRECT, SPECIAL, INCIDENTAL, OR CONSEQUENTIAL DAMAGES, WHETHER BASED ON CONTRACT, TORT, OR ANY OTHER LEGAL THEORY.

ASSISTANCE

Product maintenance agreements and other customer assistance agreements are available for Hewlett-Packard products.

For any assistance, contact your nearest Hewlett-Packard Sales and Service Office. Addresses are provided at the back of this manual.

SAFETY CONSIDERATIONS

GENERAL

This product and related documentation must be reviewed for familiarization with safety markings and instructions before operation.

This product is a Safety Class I instrument (provided with a protective earth terminal).

BEFORE APPLYING POWER

Verify that the product is set to match the available line voltage and the correct fuse is installed.

SAFETY EARTH GROUND

An uninterruptible safety earth ground must be provided from the main power source to the product input wiring terminals, power cord, or supplied power cord set.

SAFETY SYMBOLS



Instruction manual symbol: the product will be marked with this symbol when it is necessary for the user to refer to the instruction manual (refer to Table of Contents).



Indicates hazardous voltages



Indicates earth (ground) terminal

WARNING

The WARNING sign denotes a hazard. It calls attention to a procedure, practice, or the like, which, if not correctly performed or adhered to, could result in personal injury. Do not proceed beyond a WARNING sign until the indicated conditions are fully understood and met.

CAUTION

The CAUTION sign denotes a hazard. It calls attention to an operating procedure, practice, or the like, which, if not correctly per-

formed or adhered to, could result in damage to or destruction of part or all of the product. Do not proceed beyond a CAUTION sign until the indicated conditions are fully understood and met.

WARNING

Any interruption of the protective (grounding) conductor (inside or outside the instrument) or disconnecting the protective earth terminal will cause a potential shock hazard that could result in personal injury. (Grounding one conductor of a two conductor outlet is not sufficient protection).

Whenever it is likely that the protection has been impaired, the instrument must be made inoperative and be secured against any unintended operation.

If this instrument is to be energized via an auto-transformer (for voltage reduction) make sure the common terminal is connected to the earth terminal of the power source.

Servicing instructions are for use by service-trained personnel only. To avoid dangerous electric shock, do not perform any servicing unless qualified to do so.

Adjustments described in the manual are performed with power supplied to the instrument while protective covers are removed. Energy available at many points may, if contacted, result in personal injury.

Capacitors inside the instrument may still be charged even if the instrument has been disconnected from its source of supply.

For continued protection against fire hazard, replace the line fuse(s) only with 250V fuse(s) of the same current rating and type (for example, normal blow, time delay, etc.). Do not use repaired fuses or short circuited fuseholders.

CONTENTS

Section 1 – General Information

Introduction	1-1
Specifications	1-1
Safety Considerations	1-1
Instruments Covered by Manual	1-1
Description	1-2
Options	1-2
Electrical Options	1-2
Mechanical Options - Serial Prefixes 2234A to 2513A	1-2
Mechanical Options - Serial Prefixes 2516A and Above	1-3
Hewlett-Packard Interface Bus	1-3
Compatibility	1-3
HP-IB Address	1-3
Accessories Supplied	1-3
Equipment Available	1-3
Recommended Test Equipment	1-4

Section 2 – Installation

Introduction	2-1
Initial Inspection	2-1
Preparation for Use	2-1
Power Requirements	2-1
Line Voltage and Fuse Selection	2-1
Power Cables	2-2
HP-IB Address Selection	2-2
Mating Connectors	2-2
Operating Environment	2-3
Bench Operation	2-3
Rack Mounting	2-3
Storage and Shipment	2-3
Environment	2-3
Packaging	2-7

Section 3 – Operation

Introduction	3-1
Operating Characteristics	3-1
Local Operation	3-1
Remote Operation	3-1
Operator's Checks	3-1
Oven Fuse Replacement	3-1
Front and Rear Panel	3-6

Section 3 – Operation (cont'd)

General Operating Instructions 3-7

 Reference Selection 3-8

 Status Messages 3-8

 Amplitude Correction 3-8

Remote Operation, Auxiliary Control 3-8

 AUX Input Lines 3-8

 AUX Output Lines 3-9

Remote Operation, Hewlett-Packard Interface Bus 3-9

 HP-IB Compatibility 3-9

 HP-IB Messages 3-11

 Local Mode 3-11

 Addresses 3-11

 Turn-On Default Conditions 3-11

 Displays 3-12

 Receiving Data Messages 3-12

 Sending Data Messages 3-13

 Receiving the Trigger Message 3-14

 Receiving the Clear Message 3-14

 Receiving the Remote Message 3-14

 Receiving the Local Message 3-14

 Receiving the Local Lockout Message 3-14

 Receiving the Clear Lockout/Set Local Message 3-14

 Receiving the Pass Control Message 3-14

 Sending the Request Service Message 3-14

 Sending the Status Byte Message 3-14

 Sending the Status Bit Message 3-14

 Receiving the Abort Message 3-14

Detailed Operating Instructions 3-17

Section 4 – Performance Tests

Introduction 4-1

Equipment Required 4-1

Test Record 4-1

Operation Verification 4-1

Performance Test 1 - Operation Verification 4-3

Performance Test 2 - AM and FM Tests 4-8

Performance Test 3 - Phase Modulation Test (Option 002 Only) 4-14

Performance Test 4 - Pulse Modulation Test 4-18

Performance Test 5 - BPSK Test 4-20

Performance Test 6 - Level Accuracy and Flatness Test 4-22

Performance Test 7 - Level Accuracy Test (Optional - Low Level) 4-25

Performance Test 8 - SSB Phase Noise Test 4-28

Performance Test 9 - SSB Phase Noise Test (Optional) 4-30

Performance Test 10 - Harmonics and Spurious Tests 4-33

Performance Test 11 - Internal Time Base Aging Rate Test 4-37

Performance Test 12 - Absolute SSB Phase Noise on Rear Panel 640 MHz Output
 (Option 003 Only) 4-40

Section 5 – Adjustments

Introduction	5-1
Safety Considerations	5-1
Equipment Required	5-2
Factory Selected Components	5-2
Post-Repair Adjustments	5-2
Adjustment 1 - Power Supply Voltage Adjustment	5-9
Adjustment 2 - 10 MHz Reference Oscillator Adjustment	5-11
Adjustment 3 - 40 MHz Crystal Filter Adjustment	5-12
Adjustment 4 - 160 MHz and 640 MHz Band-Pass Filter Adjustment	5-13
Adjustment 5 - 480 MHz Band-Pass Filter Adjustment	5-15
Adjustment 6 - 140 MHz Band-Pass Filter Adjustment	5-16
Adjustment 7 - Fractional-N Pretune Adjustment	5-17
Adjustment 8 - Fractional-N Correction Current Adjustment	5-19
Adjustment 9 - N-Loop ECL Adjustment	5-20
Adjustment 10 - N-Loop Phase Error Adjustment	5-21
Adjustment 11 - N-Loop Fractional-N Spur Adjustment	5-23
Adjustment 12 - Sum Loop Phase Error Adjustment	5-25
Adjustment 13 - FM Sum Loop Pretune Adjustment	5-27
Adjustment 14 - Controller Board Power Supply (-30V) Adjustment	5-28
Adjustment 15 - Reference Sum Loop Pretune Adjustment	5-29
Adjustment 16 - Reference Sum Loop Out-Of-Lock Adjustment	5-30
Adjustment 17 - Output Sum Loop Pretune Adjustment	5-31
Adjustment 18 - Output Sum Loop Out-Of-Lock Adjustment	5-32
Adjustment 19 - Variable Modulation Oscillator (VMO) Adjustments	5-33
Adjustment 20 - AM - FM Adjustments	5-34
Adjustment 21 - Phase Modulation Adjustments (Option 002 Only)	5-36
Adjustment 22 - Phase Modulation Spur Adjustments (Option 002 Only)	5-39
Adjustment 23 - BPSK Adjustments (Option 002 Only)	5-41
Adjustment 24 - Output Amplifier Bias Adjustments	5-42
Adjustment 25 - RF Level Adjustments	5-44
Adjustment 26 - ALC Loop Bandwidth Adjustments	5-46
Adjustment 27 - Pulse Modulation Adjustments	5-49
Adjustment 28 - Low Frequency Down Converter Adjustment	5-51
Adjustment 29 - Low Pass Filter Adjustments	5-53
Adjustment 30 - Z-Axis Marker Level Adjustment	5-56

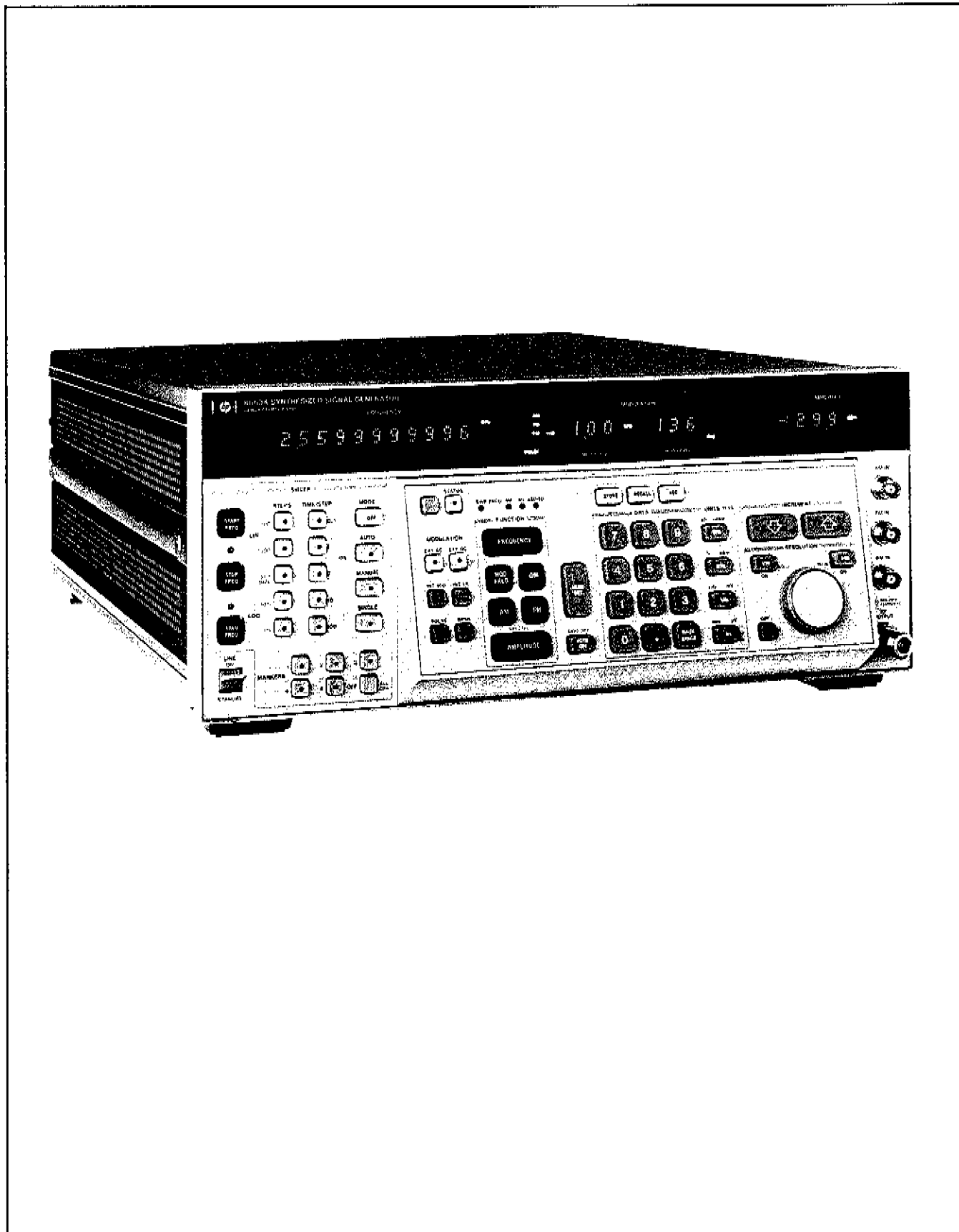

Figure 1-1. HP Model 8663A Synthesized Signal Generator

Section 1 GENERAL INFORMATION

1-1. INTRODUCTION

This manual contains information required to install, operate, test, adjust, and service the Hewlett-Packard Model 8663A Signal Generator. The HP 8663A will generally be referred to as the signal generator throughout this manual.

The HP 8663A Operating and Service manual is composed of an Operation and Calibration Manual and a three volume service manual. The Operation and Calibration Manual contains the following sections:

1. General Information
2. Installation
3. Operation
4. Performance Tests
5. Adjustments

The Service Manual (Volumes 1, 2 and 3) contain the following Sections:

6. Replaceable Parts
7. Manual Changes
8. Service

The HP part number for the Operation and Calibration Manual is shown on the title page of this manual. Part numbers for the Service Manual are shown on the title pages of Volumes 1, 2 and 3 of the Service Manual.

1-2. SPECIFICATIONS

Instrument specifications are listed in Table 1-1. These specifications are the performance standard or limits against which the instrument can be tested. Supplemental characteristics are not specifications but are typical characteristics included as additional information for the user.

1-3. SAFETY CONSIDERATIONS

This product is a Safety Class I instrument (provided with a protective earth terminal). The Signal Generator and all related documentation must be reviewed for familiarization with safety markings and instructions before operation. Refer to the Safety Considerations page found at the beginning of this manual for a summary of general safety information.

Safety information for installation and operation is found in appropriate places throughout this manual.

1-4. INSTRUMENTS COVERED BY MANUAL

Attached to the instrument is a serial number plate. The serial number is in the form: 0000A00000. It is in two parts: the first four digits and the letter are the serial number prefix and the last five digits are the suffix. The prefix is the same for all identical instruments; it changes only when a change is made to the instrument. The suffix, however, is assigned sequentially and is different for each instrument. The contents of this manual apply to instruments with the serial number prefix(es) listed under SERIAL NUMBERS on the title page.

Manual Updates. An instrument manufactured after the printing of this manual may have a serial prefix that is not listed on the title page. An unlisted serial prefix number indicates that the instrument differs in some way from those documented in this manual.

A "MANUAL UPDATES" packet is shipped with the manual when necessary to provide you with the most current information available at the time of shipment. These packets consist of replacement and addition pages which should be incorporated into the manual to bring it up to date.

Hewlett-Packard offers a Document Update Service that will provide you with further updates as they become available.

If you operate or service instruments of different serial prefixes, we strongly recommend that you join this service immediately to ensure that your manual is kept current. For more information, refer to the Documentation Update Service reply card included with this manual or contact:

Technical Writing Department
Spokane Division
Hewlett-Packard Company
East 24001 Mission - TAF C-34
Spokane, Washington, U.S.A. 99220
Telephone (509) 921-4001

1-5. DESCRIPTION

The HP Model 8663A is a precision synthesized signal generator with the following features:

- 100 kHz to 2560 MHz frequency range
- 0.1 Hz resolution (0.2 Hz from 640 to 1280 MHz) (0.4 Hz from 1280 to 2560 MHz)
- 5×10^{-10} /day frequency stability
- +16 to -129.9 dBm output level range (with overrange to +19.9 dBm)
- +1 dB level accuracy
- AM, FM, PM, PULSE, and BPSK modulation modes
- Hewlett-Packard Interface Bus (HP-IB) capability

.... with exceptional spectral purity.

- SSB phase noise < -131 dBc/Hz at 10 kHz offset from carrier ($320 < f_c < 640$ MHz)
- Broadband noise floor < -146 dBc
- Spurious signals from -78 to -100 dBc depending on f_c
- Harmonics -30 dBc (< -25 dBc, $1280 < f_c < 2560$ MHz)

.... microprocessor control for measurement efficiency.

- Keyboard control of all functions
- Storage and recall of front panel settings
- Learn modes
- Stepping of all value-selectable parameters

.... and versatile digital sweep.

- Synthesized frequency accuracy and resolution
- Start/Stop and Span modes
- Linear or log RF and modulation sweep
- Selectable time per step
- Completely variable step size
- 5 digital markers

1-6. OPTIONS

1-7. ELECTRICAL OPTIONS

Option 001 provides the RF OUTPUT connector and the AM IN, FM IN, and Φ M IN connectors on the rear panel instead of on the front panel.

Option 002 provides the Signal Generator with phase modulation capabilities. This option also allows BPSK to be used at all RF frequency settings.

Option 003 provides guaranteed absolute single sideband phase noise performance from the 640 MHz output. This output is available only on instruments with serial prefixes 2411A and above.

Option 900 provides an ac power cable (HP part number 8120-1351) for use in the United Kingdom, Cyprus, Nigeria, Rhodesia, or Singapore. Refer to Table 2-2 for description.

Option 901 provides an ac power cable (HP part number 8120-1369) for use in Australia or New Zealand. Refer to Table 2-2 for description.

Option 902 provides an ac power cable (HP part number 8120-1689) for use in Eastern and Western Europe, Saudi Arabia, Egypt. Refer to Table 2-2 for description.

Option 903 provides an ac power cable (HP part number 8120-1378) for use in the United States or Canada. Refer to Table 2-2 for description.

Option 906 provides an ac power cable (HP part number 8120-2104) for use in Switzerland. Refer to Table 2-2 for description.

Option 912 provides an ac power cable (HP part number 8120-2956) for use in Denmark. Refer to Table 2-2 for description.

Option 917 provides an ac power cable (HP part number 8120-4211) for use in South Africa and India. Refer to Table 2-2 for description.

1-8. MECHANICAL OPTIONS (Serial Prefixes 2234A to 2513A)

The following kits might have been ordered and received with the Signal Generator (they are shown in Figure 1-2). If they were not received with the original shipment and are now required, they may be ordered from your nearest Hewlett-Packard office, using the part numbers included in each of the following paragraphs.

Front Handle Kit, Option 907. This kit contains front handles and mounting hardware. Order HP part number 5061-0090 for the basic kit and 2190-0048 for lockwashers (8 required).

Rack Mount Kit, Option 908. This kit contains flanges and hardware for mounting the Generator in a standard rack of 482.5 mm (19 inches). Order HP part number 5061-0078.

Rack Mount Kit with Front Handles, Option 909. This kit contains flanges, handles and mounting hardware (the flanges are different than the Option 908 flanges). Order HP part number 5061-0084 for the basic kit and 2190-0009 for lockwashers (8 required).

1-9. MECHANICAL OPTIONS (Serial Prefixes 2516A and Above)

The following kits might have been ordered and received with the Signal Generator (they are shown in Figure 1-2). If they were not received with the original shipment and are now required, they may be ordered from your nearest Hewlett-Packard office, using the part numbers included in each of the following paragraphs.

Front Handle Kit, Option 907. This kit contains front handles and mounting hardware. Order HP part number 5061-9690 for the basic kit and 2190-0048 for lockwashers (8 required).

Rack Mount Kit, Option 908. This kit contains flanges and hardware for mounting the Generator in a standard rack of 482.5 mm (19 inches). Order HP part number 5061-9678.

Rack Mount Kit with Front Handles, Option 909. This kit contains flanges, handles and mounting hardware (the flanges are different than the Option 908 flanges). Order HP part number 5061-9684 for the basic kit and 2190-0009 for lockwashers (8 required). Option 001 provides the RF OUTPUT connector and the AM IN, FM IN, and PM IN connectors on the rear panel instead of on the front panel.

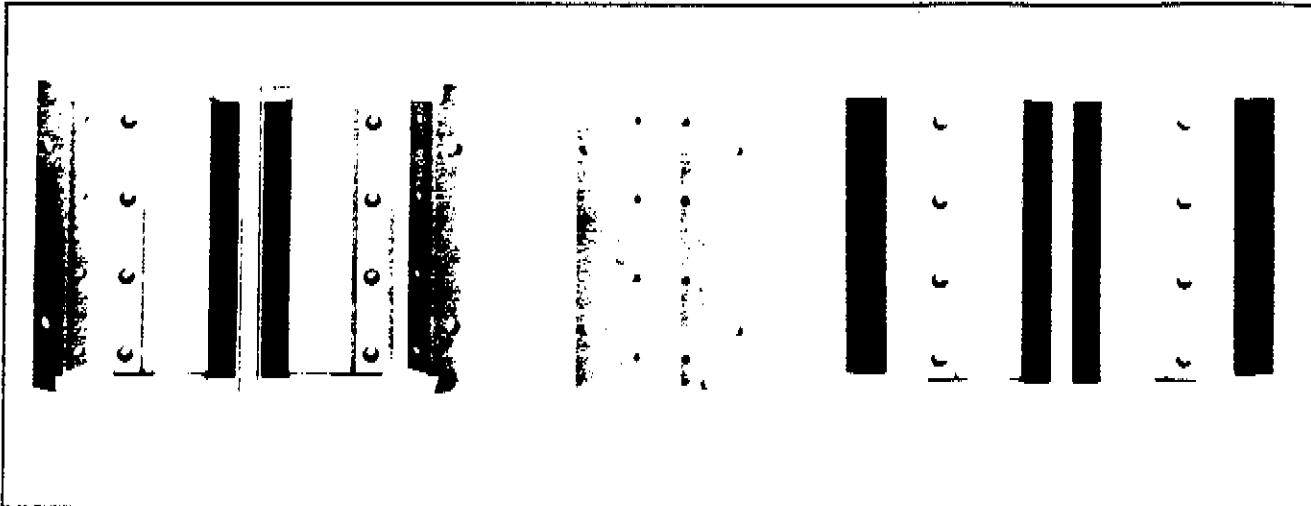

Figure 1-2. Rack Mounting Options

1-10. HEWLETT-PACKARD INTERFACE BUS

1-11. COMPATIBILITY

The Signal Generator has an HP-IB interface and can be used with any HP-IB computing controller or computer for automatic system applications. The Signal Generator is fully programmable via the HP interface Bus. HP-IB is Hewlett-Packard's implementation of IEEE Standard 488 and the identical ANSI Standard MC1.1. The Generator's compatibility with HP-IB is defined by the following list of interface functions: SH1, AH1, T6, TE0, L3, LE0, SR1, RL1, PP0, DC1, DT1, and C0. For more detailed information, refer to Section III of this manual.

1-12. HP-IB ADDRESS

Two thumbwheel switches inside the top cover select the address code. This procedure is described in paragraph 2-7, and is intended for service-trained persons only. However, the decimal equivalent of the five-bit address code can be displayed on the front panel by selecting Special Function 82 (refer to the detailed operating instruction entitled "HP-IB Address Display").

1-13. ACCESSORIES SUPPLIED

The accessories supplied with the Signal Generator are shown in Figure 1-1. The power cable is selected at the factory according to the voltage available in the country of destination. For the part numbers of the power cable refer to the paragraph titled Power Cables. For Generators shipped to countries using 115 volts, a set of fuses for 230 volts operation is also supplied.

1-14. EQUIPMENT AVAILABLE

A service accessory kit, Hewlett-Packard accessory number 11714A, is required for servicing and troubleshooting the Signal Generator. The service kit contains extender boards, connectors, cables, adapters and other service aids. For more details on the service accessory kit, refer to Table 1-5.

1-15. RECOMMENDED TEST EQUIPMENT

Table 1-4 lists the equipment required for maintaining the Generator. The Critical Specification column describes the essential requirements for each piece of test equipment. Other equipment can be substituted if it meets or exceeds these critical specifications.

The Recommended Model column may suggest more than one model. The first model shown is usually the least expensive, single-purpose model. Alternate models are suggested for additional features that would make them a better choice in some applications. For example, reasons for recommending an alternate model might be:

- HP-IB programmability
- or -
- Multi-function capability (that is, one model can replace two or more single-purpose models)

Table 1-1. Specifications (1 of 5)

Electrical Characteristics	Performance Limits	Conditions
FREQUENCY		
Range	100 kHz to 2560 MHz 2559.9999996 MHz	
Resolution	0.1 Hz 0.2 Hz 0.4 Hz	100 kHz to 640 MHz 640 kHz to 1280 MHz 1280 kHz to 2560 MHz
Accuracy and Stability	Same as reference oscillator	
Internal Reference Oscillator: ¹		
Frequency	10 MHz	
Aging Rate	5×10^{-10} /day	After ten day warm-up (typically 24 hours in normal operating environment)
SPECTRAL PURITY		
Residual SSB Phase Noise in 1 Hz Bandwidth	-100 dBc -112 dBc -121 dBc -131 dBc -132 dBc	$320 \leq f_c \leq 640$ MHz 10 Hz offset from carrier 100 Hz offset from carrier 1000 Hz offset from carrier 10 kHz offset from carrier 100 kHz offset from carrier
SSB Broadband Noise Floor in 1 Hz Bandwidth, 3 MHz offset from carrier	<145 dBc	$\geq +10$ dBm output level; 120 to 640 MHz, ϕ M off
Spurious Output Signals (subharmonically related ²)	None < -70 dBc < -40 dBc	0.1 to 640 MHz 640 to 1280 MHz 1280 to 2560 MHz
Spurious Output Signals (subharmonically related ²)	< -90 dBc < -100 dBc < -96 dBc < -90 dBc < -84 dBc < -78 dBc	0.1 to 120 MHz 120 to 160 MHz 160 to 320 MHz 320 to 640 MHz 640 to 1280 MHz 1280 to 2560 MHz
NOTE: In the remote mode it is possible to have microprocessor clock related spurious signals spaced 3 MHz apart at levels typically < -80 dBc.		
Spurious Output Signals (Power line (60 Hz) related or microphonically generated (within 300 Hz from carrier))	< -90 dBc < -85 dBc < -80 dBc < -75 dBc < -70 dBc < -65 dBc	0.1 to 120 MHz 120 to 160 MHz 160 to 320 MHz 320 to 640 MHz 640 to 1280 MHz 1280 to 2560 MHz
NOTE: At 50 Hz line frequency, power line or microphonically related spurious signals may be up to 3 dB higher and appear at offsets as high as 1 kHz from the carrier.		
¹ The internal reference oscillator is kept at operating temperature in STANDBY mode with the instrument connected to Mains power. ² Subharmonically related signals are $f/2$, $3f/2$, etc.		

Table 1-1. Specifications (2 of 5)

Electrical Characteristics	Performance Limits	Conditions
SPECTRAL PURITY Cont. Harmonics	$< -30 \text{ dBc} \leq +13 \text{ dBm}$ output $< -25 \text{ dBc}$, $+13 \text{ dBm}$ to $+16 \text{ dBm}$ output $< -25 \text{ dBc}$	0.1 to 1280 MHz 1280 to 2560 MHz
OUTPUT (+15 to +45 degrees C) Range Resolution Absolute Level Accuracy ^{3,4} Flatness Flatness in Sweep Mode (Uncorrected) ⁴	$+16$ to -129.9 dBm (1.41V to 0.072 μV into 50 ohms) 0.1 dB $< \pm 1.0 \text{ dB}$ $< \pm 3.0 \text{ dB}$ Same as Absolute Level Accuracy $< \pm 1.1 \text{ dB}$ $< \pm 1.5 \text{ dB}$	 $+16$ to -119.9 dBm -120 dBm and below 0.1 MHz to 1280 MHz 0.1 MHz to 2560 MHz
AMPLITUDE MODULATION Depth Resolution Incidental PM AM Indicator Accuracy AM Rates: Internal AM External Bandwidth (1 dB) Depth 90%, DC Offset $< 10 \text{ mV}$ AM Distortion (400 Hz and 1 kHz rates)	0 to 95% 0.1% < 0.15 radians peak < 0.10 radians peak < 0.33 radians peak $\pm(6\%$ of setting $+1\%$ AM) 10 Hz to 10 kHz dc to 1.5 kHz dc to 5 kHz dc to 10 kHz $< 2\%$ $< 3\%$ $< 4\%$	Output level $\leq +10 \text{ dBm}$ and below, ⁵ 0 to 95% AM 0.15 to 640 MHz; 30% AM (1 kHz rate) 640 to 1280 MHz; 30% AM (1 kHz rate) 1280 to 2560 MHz; 30% AM (1 kHz rate) Depth $\leq 90\%$ AM; for 400 Hz and 1 kHz AM rates 0.15 to 1 MHz 1 to 10 MHz 10 to 2560 MHz 0 to 30% AM 30 to 70% AM 70 to 90% AM
³ Includes flatness, attenuator error, detector error and measurement uncertainty. ⁴ The 8663A uses a microprocessor level accuracy enhancement routine to achieve $\pm 1 \text{ dB}$ absolute level accuracy and flatness for levels between $+16 \text{ dBm}$ and -119 dBm . This enhancement can be disabled with a special function. ⁵ AM is possible with an output level $> \pm 10 \text{ dBm}$, however, its modulation characteristics are not specified.		

Table 1-1. Specifications (3 of 5)

Electrical Characteristics	Performance Limits	Conditions
FREQUENCY MODULATION		
FM Rates:		
Internal	10 Hz to 100 kHz	
External ac	20 Hz to 100 kHz	1 dB bandwidth
External dc	dc to 100 kHz	1 dB bandwidth
Maximum Peak Deviation (external ac and internal)	The smaller of 100 kHz or $f_{mod} \times 500$ The smaller of 25 kHz or $f_{mod} \times 125$ The smaller of 50 kHz or $f_{mod} \times 250$ The smaller of 100 kHz or $f_{mod} \times 500$	0.1 to 120 MHz 120 to 160 MHz 160 to 320 MHz 320 to 640 MHz
	The smaller of 200 kHz or $f_{mod} \times 1000$ The smaller of 400 kHz or $f_{mod} \times 2000$	640 to 1280 MHz 1280 to 2560 MHz
Maximum Peak Deviation (external dc)	100 kHz 25 kHz 50 kHz 100 kHz 200 kHz 400 kHz	0.1 to 120 MHz 120 to 160 MHz 160 to 320 MHz 320 to 640 MHz 640 to 1280 MHz 1280 to 2560 MHz
Indicated FM Accuracy	$\pm 7\%$ of reading (+10 Hz)	50 Hz to 20 kHz rates
FM Deviation Resolution		
Deviation ≤ 100 kHz	0.1 kHz 0.2 kHz 0.4 kHz	$0.1 \leq f_c \leq 640$ MHz $640 \leq f_c \leq 1280$ MHz $1280 \leq f_c \leq 2560$ MHz
Deviation > 100 kHz	N/A 1 kHz 1 kHz	$0.1 \leq f_c < 640$ MHz $640 \leq f_c < 1260$ MHz $1260 \leq f_c < 2560$ MHz
PHASE MODULATION		
Maximum Peak Phase Deviation	100 deg 25 deg 50 deg 100 deg 200 deg 400 deg	0.1 to 120 MHz 120 to 160 MHz 160 to 320 MHz 320 to 640 MHz 640 to 1280 MHz 1280 to 2560 MHz
Resolution	1 deg 2 deg 4 deg	0.1 to 640 MHz 640 to 1280 MHz 1280 to 2560 MHz
PM Indicator Accuracy	$\pm(12\%$ of setting +3% of full scale)	+15°C to +35°C
Maximum Phase Modulation Rates 50 Ω Input Impedance	10 kHz 100 kHz 2 MHz 5 MHz 10 MHz	$0.15 \text{ MHz} \leq f_c < 10 \text{ MHz}$ $10 \text{ MHz} \leq f_c < 50 \text{ MHz}$ $50 \text{ MHz} \leq f_c < 220 \text{ MHz}$ $220 \text{ MHz} \leq f_c < 640 \text{ MHz}$ $640 \text{ MHz} \leq f_c < 2560 \text{ MHz}$

Table 1-1. Specifications (4 of 5)

Electrical Characteristics	Performance Limits	Conditions
PHASE MODULATION Cont'd 600 Ω Input Impedance Distortion	10 kHz 100 kHz 2 MHz 10%	$0.15 \text{ MHz} \leq f_c < 10 \text{ MHz}$ $10 \text{ MHz} \leq f_c < 50 \text{ MHz}$ $50 \text{ MHz} \leq f_c < 2560 \text{ MHz}$
PULSE MODULATION ⁶ On/Off Ratio Rise and Fall Time (10% to 90%) Pulse Repetition Frequency Minimum Pulse Width	>85 dB >80 dB <250 ns <800 ns <100 ns 10 Hz to 99.9 kHz (50% duty cycle) 10 Hz to 2 MHz 10 Hz to 5 MHz 1 μ s	$f_c \leq 640 \text{ MHz}$ $50 \text{ MHz} < f_c < 640 \text{ MHz}$ $50 \text{ MHz} \leq f_c < 120 \text{ MHz}$ $120 \text{ MHz} \leq f_c < 640 \text{ MHz}$ $f_c \geq 640 \text{ MHz}$ Internal External, $50 \text{ MHz} \leq f_c < 640 \text{ MHz}$ External, $f_c < 640 \text{ MHz}$ Duty cycle < 50%
BINARY PHASE SHIFT KEYING ⁷ Carrier Null, 100 kHz Square Wave	> 20 dB > 17 dB	$120 \text{ MHz} \leq f_c < 640 \text{ MHz}$ $f_c \geq 640 \text{ MHz}$ (Option 002 only, +15°C to +35°C)
INTERNAL MODULATION SYNTHESIZER Frequency Range Frequency Resolution Frequency Accuracy	10 Hz to 99.9 kHz 3 digits Same as reference oscillator.	
GENERAL Operating Temperature Range Power Requirements: Line Voltage 115V Setting 230V Setting Line Frequency Power Dissipation	0 to +55°C 90 to 126V 198 to 252V 48 to 66 Hz 450 VA maximum	
⁶ Pulse modulation is available for RF frequencies below 50 MHz but is not specified. ⁷ BPSK is standard for RF frequencies up to 640 MHz. With Option 002, BPSK is available at all RF frequencies. For RF frequencies up to 640 MHz, standard BPSK modulation is available at rates above 100 kHz, but is unspecified. BPSK cannot be simultaneously selected with Option 002 phase modulation at 640 MHz and above or with pulse modulation.		

Table 1-1. Specifications (5 of 5)

Electrical Characteristics	Performance Limits	Conditions
GENERAL Cont'd Electromagnetic Interference (EMI) Net Weight Shipping Weight Dimensions ⁸ : Height Width Depth	MIL STD 461A and VDE 0871 33.8 kg (74 lbs) 40 kg (88 lbs) 178 mm (7.0 in.) nominal 425 mm (16.75 in.) nominal 642 mm (23.3 in.) nominal	Conducted and radiated interference is within the requirements of methods CE03 and RE02 of MIL STD 461A as well as VDE 0871. Depth includes front-panel depth of 45 mm (1.75 in.)
⁸ Dimensions are for general information only. If dimensions are required for building special enclosures, contact your HP office.		

Table 1-2. Supplemental Characteristics

Supplemental characteristics are typical, but nonwarranted performance parameters. They are only intended to provide information which can be useful in determining instrument application.

FREQUENCY

Internal: The internal reference oscillator accuracy is a function of time base calibration \pm aging rate \pm temperature effects \pm line voltage effects. Temperature and line voltage effects are typically $<3.5 \times 10^{-11}/^{\circ}\text{C}$ and $<1 \times 10^{-10}/\pm 10\%$ line voltage change.

External: Any 5 MHz ($\pm 0.005\%$) frequency standard at a level of 1 V_{rms} ± 0.1 volt or any 10 MHz ($\pm 0.005\%$) standard at a level of 0.5 to 0.7 V_{rms} into 50 Ω (rear-panel connector).

Reference Output (Source Impedance 65 Ω): Reference signal (INT or EXT) available from rear-panel connector at a level of >0.5 V_{rms} into 50 Ω (Output is always 10 MHz even with 5 MHz external reference frequency.)

Frequency Switching Speed:¹ Total switching time depends on the programming mode used. The 8663A RF settling time is 250 μs , to be within 1 kHz and 400 μs to be within 100 Hz. The table below gives typical total switching time to be within 100 Hz. (All data for 11 digits of frequency change.)

Programming Mode	Microprocessor Time	Settling Time	Total Switching Time
String	12.1 ms	400 μs	12.5 ms
Character	8.3 ms	400 μs	8.7 ms
Remote Sweep	In these modes, micro-processor time and RF time overlap.		700 μs
Fast Learn			510 μs
Frequency Hop	130 μs	400 μs	530 μs

OUTPUT

Impedance: 50 Ω nominal.

SWR: <1.5

Level Switching Time: 60 ms from last command statement to stable output.

AMPLITUDE MODULATION

External Input Impedance: 600 Ω

External Input Level Required for Calibrated Operation: 1V peak. Front panel, input-level annunciator indicates 1V peak $\pm 2\%$.

FREQUENCY MODULATION

Measured Center Frequency Stability in DC Mode

f _c (MHz)	Center Frequency Accuracy	Measured Center Frequency Stability
0.01-120	± 10 kHz	± 200 Hz/hr
120-160	± 2.5 kHz	± 40 Hz/hr
160-320	± 5 kHz	± 100 Hz/hr
320-640	± 10 kHz	± 200 Hz/hr
640-1280	± 20 kHz	± 400 Hz/hr
1280-2560	± 40 kHz	± 800 Hz/hr

Input Impedance (Front Panel Input): 600 Ω nominal.

External Input Level Required for Calibrated Operation: 1V peak. Front panel, input-level annunciator indicates 1V peak $\pm 2\%$. (When greater accuracy is required, voltage of modulating signal should be monitored externally.)

NOTE

The EXTERNAL SOURCE annunciators will not provide a reliable indication if modulation rate is <20 Hz or if the Generator is sweeping with Time/Step ≤ 10 ms.

Auxiliary FM Input: Rear-panel connector for FM modulation. Operates independently allowing simultaneous FM modulation with two tones. Input impedance: 5.1 k Ω ; 4V peak yields maximum allowable deviation.

PULSE MODULATION

Pulse Delay Time: <150 ns

External Input Impedance: 50 Ω dc-coupled

External Input Level Required: $>2.5\text{V}$ —On, $<0.5\text{V}$ —Off (not to exceed $\pm 10\text{V}$).

BINARY PHASE SHIFT KEYING

External Input Impedance: 50 Ω , dc-coupled

External Input Level Required: $>2.5\text{V}$ —On, $<0.5\text{V}$ —Off (not to exceed $\pm 10\text{V}$).

PHASE MODULATION

External Input Impedance: 50 Ω , 600 Ω selected with a special function. Ac or dc coupling.

Low Frequency ac Coupling Limit: 200 Hz, 50 Ω
20 Hz, 600 Ω

External Input level Required for Calibrated Operation:
50 Ω input: 1V peak from source with SWR $<1.21 : 1$
600 Ω input: 1V peak. (Front panel MOD LEVEL annunciator indicates calibrated level $\pm 5\%$ for rates ≤ 100 kHz)

INTERNAL MODULATION SYNTHESIZER

Output Level: 1V peak into 600 Ω , available at rear panel.

Output Impedance: 600 Ω

Flatness: $< \pm 1\%$ referenced to 1 kHz

Distortion: $<1\%$

¹ Due to bandwidth switching of the automatic internal leveling loop, brief level inaccuracies (i.e., typically <30 ms) may occur when switching through exactly 150 kHz and exactly 1 MHz RF output frequencies

Table 1-3. Features (1 of 2)

Electrical Characteristics	Description
DIGITAL SWEEP Start-Stop Sweep Span Sweep Sweep Width Step Size Sweep Speed Log Sweep Frequency Markers Intensity Markers Amplitude Markers Marker Sweep Display Blanking Sweep Output	Sweeps between two selected RF or modulation frequencies. Symmetrical sweep about center RF or modulation frequency selected. Determined by frequency resolution and frequency range of instrument. Choice of 100 or 1000 steps per sweep, or set to any value within the frequency resolution of the instrument. Five selectable speeds: 0.5 Ms, 1 ms, 2 ms, 10 ms, and 100 ms per step (0.5 ms is nominal value which will vary depending on use of markers or log sweep). Two choices available in increasing steps of 10% or 1% of the last frequency. Five digital markers. Resolution and accuracy same as RF output. (Not available in modulation sweep.) Z-axis modulation of CRT display. Rear panel signal (5 kHz triangle wave) can be applied to AM input connector to provide adjustable amplitude markers. Start/stop sweeps between any two frequency markers can be selected. 250 μ s positive pulse (TTL levels) available at rear panel for display blanking during frequency switching. 0 to 10V (nominal) staircase ramp. 0V at start of sweep; approximately +10V at end of sweep regardless of sweep width. 10,000 points maximum.
SWEEP MODE Auto Single Manual	Sweep repeats automatically. Single sweep activated by front-panel keyboard. Sweep controlled by front-panel knob.
REMOTE OPERATIONS HP-IB (IEEE 488 Capability): Interface Functions Controlled Auxiliary Control: Interface Functions Controlled	Hewlett-Packard Interface Bus (HP-IB). HP-IB is Hewlett-Packard's implementation of IEEE Standard 488 (and identical ANSI Standard MC1.1). The generator's compatibility with HP-IB is defined by the following list of interface functions: SH1, AH1, T6, TE0, L3, LE0, SR1, RL1, PP0, DC1, DT1 AND C0. All functions controlled from the front panel, with the exception of the power switch, are programmable with the same accuracy and resolution as in manual mode. Rear panel 14-pin Micro Ribbon connector. Step Up/Step Down: Same as INCREMENT keys on keyboard. Stop Sweep: Puts sweep in manual mode. Continue Sweep: Puts sweep in auto mode. Single Sweep: Initiates single sweep.

Table 1-3. Features (2 of 2)

Electrical Characteristics	Description
REMOTE OPERATIONS (Cont'd) Auxiliary Control: Functions Controlled (Cont'd)	<p>Sequence: Same as sequence key on keyboard.</p> <p>Start-Stop Sweep: Sweeps between two selected RF or modulation frequencies.</p> <p>Input Required: Contact closure to ground or 5 μs negative-true TTL pulse. Internally installed jumper determines mode.</p> <p>Outputs: 5 μs negative-true TTL pulse output under following conditions:</p> <ol style="list-style-type: none"> 1. Change in signal parameter; for example, frequency, amplitude, modulation, 2. End of sweep, 3. Pen Up/Down (in single sweep mode only). When Special Function 91 is enabled, the auxiliary connector inputs will recall Register 1-9 contents (Frequency Hop).

Table 1-4. Recommended Test Equipment (1 of 3)

Instrument	Critical Specification	Recommended Model	Use*
Amplifier, Low Noise	Input/Output Impedance: 50 ohms Frequency Bandwidth: 1 kHz to 1 MHz Noise Figure: <3 dB Gain: 40 ±1 dB	HP 08640-60506 Requires 19-25 Vdc Power Supply	P
Amplifier, Wideband	Gain: 26 dB Frequency Range: 100 kHz to 1280 MHz Impedance: 50 ohms Connector: Type N	HP 8447D Option 010	P
Analyzer, Audio	Frequency Range: 20 Hz to 100 kHz Minimum Distortion Measurement: <0.1% Audio Source Output Level: >V _{rms} Audio Source Distortion: <0.01%	HP 8903B	P, A
Analyzer, Modulation	Accuracy: ±2% of reading AM Rejection: <30 Hz at 50% AM (3 kHz BW) FM Rejection: <0.2% AM (50 kHz FM)	HP 8901A	P, A
Analyzer, Signature	No known substitute. Provides preferred method for troubleshooting digital circuitry.	HP 5005A, HP 5005B HP 5006A	T
Analyzer, Spectrum	Frequency Range: 0.1 to 5600 MHz Resolution Bandwidth: ≤1 kHz	HP 8565A	P, A, T
Analyzer, Spectrum	Frequency Range: 100 Hz to 150 kHz Resolution Bandwidth: ≤10 Hz Tracking Generator Feature (required for one adjustment not generally performed: that is, the AGC Bandwidth Adjustment)	HP 8556A/ HP 8552B/141T	P, A
Attenuator, Fixed	Attenuation: As required by performance test Frequency Range: 10 kHz to 1300 MHz Accuracy: ±0.1 dB SWR: <1.3	HP 8491A	P
Attenuator, 1 dB Steps	Steps: 1 dB from 0 dB to 10 dB Frequency Range: 100 to 300 MHz	HP 355C or HP 8494G with HP 11713A	A
Attenuator, 10 dB Steps	Steps: 10 dB from 0 dB to 50 dB Frequency Range: 100 to 300 MHz	HP 355D or HP 8496G with HP 11713A	A
Cable, RF	Connector: UG-210/U Type N (male)	HP 11500B	P, A
Controller, HP-IB	HP-IB compatibility as defined by IEEE Standard 488-1975 and the identical ANSI Standard MC1.1: SH1, AH1, T2, TE0, L2, LE0, SR0, RL0, PP0, DC0, DT0, AND C1, 2, 3, 4, 5.	HP 9826, HP 9836	P, T
Counter, Frequency	Range: 2560 MHz Resolution: 0.1 Hz External Time Base Capability	HP 5328A Option 031 or HP 5328A Opt. 011 & 031	P, A, T
* P=Performance A=Adjustments T=Troubleshooting			

Table 1-4. Recommended Test Equipment (2 of 3)

Instrument	Critical Specification	Recommended Model	Use*
Detector, RF	Frequency Range: 10 to 2600 MHz	HP 8470B	P, A, T
Filter, Low-Pass	Bandwidth: 1 MHz Impedance: 50 ohms	See Figure 1-2	P
Function Generator	Level: 1 Vpk minimum into 600 ohms Frequency: 10 kHz Distortion: <0.1%	HP 3325A	P, A
Generator, Pulse	Repetition Rate: 10 Hz to 5 MHz Output Level: TTL compatible Rise/Fall Time: <10 ms	HP 8111A	P
Generator, Signal (Reference for Optional SSB Phase Noise Test)	Frequency: .01 to 2560 MHz Output: -50 dBm SSB Phase Noise: same or better than the specification for the Generator under test.	HP 8663A	P, A
Generator, Tracking	Frequency Range: 10 to 1200 MHz Output Level: >0 dBm Compatible with HP 8565A Spectrum Analyzer	HP 8663A Option 059	A
Kit, Service Accessory	Required for servicing and troubleshooting. See Table 1-4 for parts listing and description.	HP 11714A	A, T
Mixer	Frequency: 0.2 to 500 MHz Type: Double Balanced	HP 10514A	P
Mixer	Frequency: 500 to 2560 MHz Type: Double Balanced	Watkins-Johnson M1J	P
Oscillator, Sweep	Frequency Range: 10 to 2000 MHz Output Level: > +3 dBm Capable of generating markers	HP 8350A/ HP 83522A	A
Oscilloscope	Vertical Sensitivity: 10 mV/division Bandwidth: 50 MHz	HP 1741A	P, A, T
Power Meter and Sensor	Frequency Range: 250 kHz to 1300 MHz Power Range: +17 to -60 dBm Accuracy: ± 0.2 dB	HP 436A with 8482A & 8484A or HP 436A, Opt. 022 with 8482A & 8484A	P, A
Power Supply, dc	Range: 0 to 25 Vdc Current: 500 mA	HP 6002A Option 001	A, T

* P=Performance A=Adjustments T=Troubleshooting

Table 1-4. Recommended Test Equipment (3 of 3)

Instrument	Critical Specification	Recommended Model	Use*
Standard, Frequency	Frequency: 10 MHz Long Term Stability: $<1 \times 10^{-10}$ /24 hr	HP 5065A	P, A
Voltmeter, Digital (DVM)	Accuracy: $4\frac{1}{2}$ digit, $\pm 0.05\%$ of reading ± 1 digit Range: 10 mV to 600V Sensitivity: 10 μ V	HP 3478A	P, A, T
* P=Performance A=Adjustments T=Troubleshooting			

Table 1-5. 11714A Service Accessory Kit

Item Number	HP Part Number	CD	Qty	Description
1	08662-60276	0	3	Extender Board (15 pins)
2	08662-60275	9	3	Extender Board (18 pins)
3	08662-60277	1	3	Extender Board (10 pins)
4	08662-60274	8	3	Extender Board DCU (2 x 18 pins)
5	08662-60271	5	1	Extender Board Power Supply (10 and 15 pins)
6	08662-60273	7	1	Extender Board Power Supply (22 pins)
7	08662-60075	7	3	Test Cable (SMC to BNC)
8	08662-60080	4	4	Extender Cable
9	1251-1631	9	1	Test Data Bus Connector
10	1250-1598	5	3	RF Test Probe (AC Coupled)
11	1250-0827	1	1	SMC Adapter (Straight)
12	1250-0838	4	2	SMC Adapter (Tee)
13	08662-60196	3	1	Mixer Test Board
14	1250-0832	8	2	Adapter (BNC to SMC)
15	1250-0839	5	2	RF Termination
16	08662-60272	6	1	Extender Board Power Supply (18 pins)
17	5060-6033	4	1	Extender Board A8 Assembly (15 pins)
Not Shown	08662-10001	4	1	Verification Tape (8662A Only)
Not Shown	08662-90057	8	1	Operating Note
Not Shown	10811-90002	9	1	Operating and Service Manual
Not Shown	08663-60347	7	1	2 x 24 Extender Board Assembly

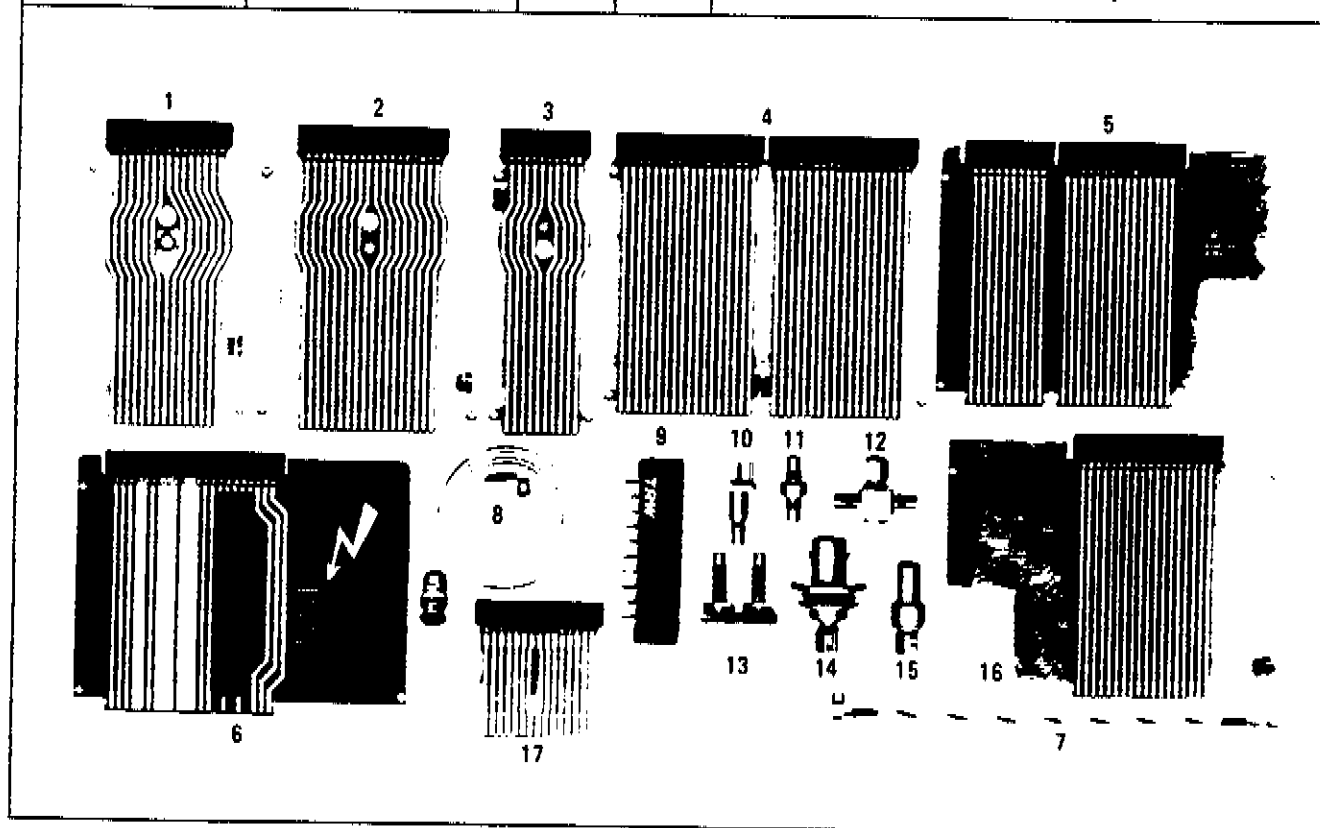

Section 2 INSTALLATION

2-1. INTRODUCTION

This section provides installation instructions for the signal generator. This section also includes information pertinent to initial inspection, power requirements, line voltage selection, HP-IB address selection, power cables, interconnection, environment, instrument mounting, storage, and shipment.

2-2. INITIAL INSPECTION

WARNING

To avoid hazardous electrical shock, do not perform electrical tests when there are signs of shipping damage to any portion of the outer enclosure (cover and panels).

Inspect the shipping container for damage. If the shipping container or cushioning material is damaged, it should be kept until the contents of the shipment have been checked mechanically and electrically. The contents of the shipment should be as shown in Figure 1-1. Procedures for checking electrical performance are given in the "Operation Verification" and "Performance Tests" in Section IV. If the contents are incomplete, if there is mechanical damage or defect, or if the instrument does not pass the electrical performance test, notify the nearest Hewlett-Packard Office. If the shipping container is damaged, or the cushioning materials show sign of stress, notify the carrier as well as the Hewlett-Packard Office. Keep the shipping materials for the carrier's inspection.

2-3. PREPARATION FOR USE

2-4. Power Requirements

The signal generator requires a power source of 115 (90-126) Vac or 230 (198-252) Vac, 48 to 66 Hz single phase. Power consumption is less than 450 volt-amperes.

WARNING

This is a Safety Class I product (provided with a protective earth terminal). An uninterruptible safety earth ground must be provided from the main power source to the product input wiring terminals, power cord, or supplied power cord set. Whenever it is likely that the protection has been impaired, the instrument must be made inoperative and be secured against any unintended operation.

If this instrument is to be energized via an autotransformer for voltage reduction, make sure the common terminal is connected to the earthed pole of the power source.

2-5. Line Voltage and Fuse Selection

CAUTION

BEFORE PLUGGING THIS INSTRUMENT into the mains (line) voltage, be sure the correct voltage and fuse have been selected.

Set the red switch on the rear panel to nominal 115V (for 90-126V) or 230V (for 198-252V).

WARNING

For protection against fire hazard, the LINE and OVEN fuses should only be 250V normal blow fuses with the correct current rating.

CAUTION

If the LINE fuse burns out, do not replace it until the cause for the failure has been determined and repaired (by a qualified service person only and specifically with resistance checks in the power supply. See Service Sheet 65). Replacing this fuse in a damaged generator can cause additional damage.

Two fuses are supplied with each instrument. One fuse has the proper rating for 110/120 Vac line operation; the other fuse is rated for 200/220 Vac operation.

One fuse is installed in the instrument at the time of shipment. The rating of the installed fuse is selected according to the line voltage specified by the customer. If the line voltage is not specified, the rating of the installed fuse will be selected according to the country of destination.

Current ratings are printed under the fuseholders on the generator's rear panel and listed with HP part numbers in Table 2-1.

Table 2-1. Line and Oven Fuse Part Numbers.

Line Voltage	Line Fuse	Oven Fuse
115V	HP 2110-0010 250V 5A Normal Blow	HP 2110-0063 250V 0.75A Normal Blow
230V	HP 2110-0083 250V 2.5A Normal Blow	HP 2110-0012 250V 0.50A Normal Blow

2-6. Power Cables

WARNING

BEFORE CONNECTING THIS INSTRUMENT, the protective earth terminal of the instrument must be connected to the protective conductor of the (mains) power cord. The mains plug shall only be inserted in a socket outlet provided with a protective earth contact. The protective action must not be negated by the use of an extension cord (power cord) without a protective conductor (grounding). Grounding one conductor of a two conductor outlet is not sufficient protection.

This instrument is equipped with a three-wire power cable. When connected to an appropriate ac power receptacle, this cable grounds the instrument cabinet. The type of power cable plug shipped with each instrument depends on the country of destination. Refer to Table 2-2 for the part numbers of the power cables available. Section I lists power cables that are configured as instrument options.

2-7. HP-IB Address Selection

The HP-IB address switches are located within the signal generator. To change the HP-IB address the top cover of the signal generator must be removed. For information describing how to display the generator's HP-IB address on the front panel, refer to the detailed operating instruction entitled "HP-IB Address Display".

WARNING

This task should be performed only by service trained persons who are aware of the potential shock hazard of working on an instrument with protective covers removed.

To avoid hazardous electrical shock, the line (mains) power cable should be disconnected before attempting to change the HP-IB address.

The following procedures describe how to locate and set the HP-IB address switches.

- a. Set the POWER switch to STANDBY and disconnect the line power cable.

NOTE

The HP-IB address changes only at instrument power-up. Thus, if the Generator is left on, the address will not change by simply changing the address switches.

- b. Remove the signal generator's top cover by removing the two plastic feet from the rear of the top cover and loosening the screw at the middle of the rear edge of the top cover.
- c. The HP-IB address switches are thumbwheel switches located behind the front-panel modulation display.
- d. The thumbwheel switch settings are in decimal code. Addresses from 00 to 30 are the only valid listen and talk addresses. Refer to Table 2-3 for the decimal equivalents of the ASCII Talk and Listen codes.
- e. Select the new address, reinstall the signal generator's top cover, and set the POWER switch to ON.

2-8. Mating Connectors

Aux Interface Connector. The rear panel AUX control connector requires a male 14-pin Micro-Ribbon (57 Series) connector. The HP part number is 1251-0142. The connector is also available from Amphenol (Oak Brook, Illinois 60521). Interconnection data for the rear panel AUX control connector is provided in Figure 2-1.

HP-IB Interface Connector. Interconnection data for the Hewlett-Packard Interface Bus is provided in Figure 2-2.

Coaxial Connectors. Coaxial mating connectors used with the Signal Generator should be either 50 ohm type BNC male, type N male or SMC male (Option 001 only) connectors that are compatible with US MIL-C-39012.

2-9. Operating Environment

The operating environment should be within the following limitations:

- Temperature 0°C to +55°C
- Humidity <95% relative at 40°C
- Altitude <4570 metres (15,000 feet)

NOTE

RF Output Level accuracy is specified only between +15 and +45 degrees C.

2-10. Bench Operation

The instrument cabinet has plastic feet and foldaway tilt stands for convenience in bench operation. (The plastic feet are shaped to ensure self-aligning of the instruments when stacked.) The tilt stands raise the front of the Signal Generator for easier viewing of the control panel.

2-11. Rack Mounting

Rack mounting information is provided with the rack mounting kits. If the kit was not ordered with the Signal Generator as an option, it can be ordered through the nearest Hewlett-Packard office. Refer to the paragraph entitled Options in Section I.

Rack Mount Slides. The following rack mount slide kits allow easy access to full-width instruments mounted in HP rack cabinets.

For non-HP rack cabinets, you will need to choose Slides and a Slide Adapter Kit. All slides lock in the fully extended position and will allow you to easily remove the instrument if necessary.

Non-tilting Rack Slides	1494-0059 Metric (1494-0017) English
Tilting Rack Slides	1494-0063 Metric (1494-0026) English
Non-HP Rack, Slide Adapter Kit	1494-0061 Metric (1494-0023) English

NOTE







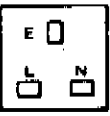

All instruments currently manufactured by Hewlett-Packard require slide kits with METRIC connecting hardware. Instruments manufactured with serial number prefixes 2234A to 2513A require English connecting hardware.

2-12. STORAGE AND SHIPMENT

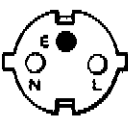
2-13. Environment

The instrument should be stored in a clean, dry environment. The following environmental limitations apply to both storage and shipment:

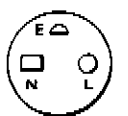
- Temperature -55°C to +75°C
- Humidity <95% relative
- Altitude <15 300 metres (50 000 feet)

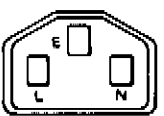
Plug Type	Cable HP Part Number	C D	Plug Description	Cable Length (inches)	Cable Color	For Use In Country
250V 	8120-1351 8120-1703	0 4	90°/STR BS1363A* 90°/90°	90 90	Mint Gray Mint Gray	United Kingdom, Cyprus, Nigeria, Rhodesia, Singapore
250V 	8120-1369 8120-0696	0 4	STR/STR NZSS198/ASC112* STR/90°	79 80	Gray Gray	Australia, New Zealand
250V 	8120-1689 8120-1692	7 2	STR/STR* STR/90°	79 79	Mint Gray Mint Gray	East and West Europe, Saudi Arabia, Egypt, (unpolarized in many nations)
125V 	8120-1378 8120-1521 8120-1751	1 6 1	STR/STR NEMA5-15P* STR/90° STR/STR	80 80 90	Jade Gray Jade Gray Jade Gray	United States, Canada, Mexico, Philippines, Taiwan U.S./Canada
100V (Same plug as above)	8120-4753 8120-4754	2 3	STR/STR STR/90°	90 90	Dark Gray Dark Gray	Japan only Japan only
250V 	8120-2104 8120-2296 8120-3997	3 4 4	STR/STR SEV1011 1959-24507 Type 12 STR/90° STR/90°	79 79 177	Gray Gray Gray	Switzerland
250V 	8120-0698	6	STR/STR NEMA6-15P	90	Black	United States, Canada
250V 	8120-2956 8120-2957 8120-3997	3 4 4	90°/STR 90°/90° STR/STR	79	Gray	Denmark
250V 	8120-4211 8120-4600	7 8	STR/STR*IEC83-B1 STR/90°	79 79	Black Gray	South Africa, India
250V 	8120-1860 8120-1575 8120-2191 8120-4379	6 0 8 8	STR/STR*CEE22-V1 (Systems Cabinet Use) STR/STR STR/90° 90°/90°	59 31 59 80	Jade Gray Jade Gray Jade Gray Jade Gray	

* Part number shown for plug is industry identifier for plug only. Number shown for cable is HP Part Number for complete cable including plug. E = Earth Ground; L = Line; N = Neutral; STR = Straight

Figure 2-2. AC Power Cables Available (P/O ERRATA)

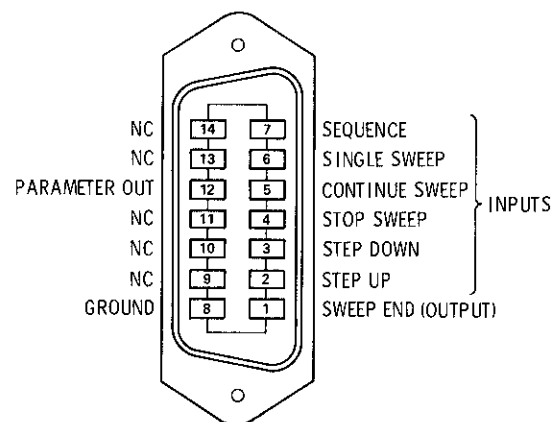

14-Pin Micro-Ribbon (57 Series) Connector

Logic Levels

The rear panel AUX connector logic levels are TTL compatible (5 μ s negative true TTL pulse or a contact closure to ground).

Internal Jumper Selection

If the signals to the rear panel AUX connector require contact debouncing (e.g., for mechanical switches), an internal jumper must be changed. The jumper is installed at the factory for electronically clean input signals (i.e., those signals that do not require the use of the debounce circuit). The jumper is located on the A2A1 Key-Code board. To change the jumper position the top cover of the Signal Generator must be removed.

WARNING

This task should be performed only by service trained persons who are aware of the potential shock hazard of working on an instrument with protective covers removed.

To avoid hazardous electrical shock, the line (mains) power cable should be disconnected before removing the generator's cover.

The following procedure describes how to locate and change the jumper position.

- a. Set the Line switch to STANDBY and disconnect the line power cable.
- b. Remove the signal generator's top cover by removing the two plastic feet from the rear of the top cover and loosening the screw at the middle of the rear edge of the top cover.
- c. The A2A1 Key-Code board is located directly behind the FREQUENCY readout display.
- d. Remove the A2 Assembly protective cover (left-hand side) by removing the two nuts.
- e. Remove the A2A1 Key-Code board by gently lifting the board's extractors (the extractors are color-keyed brown and black).
- f. The jumper is located on the upper left-hand corner of the board.
- g. To enable the debounce circuit remove the jumper from J1 and reinstall the jumper at J2.
- h. Reinstall the A2A1 Key-Code board, the A2 Assembly protective cover and the signal generator's top cover.

Figure 2-1. Aux Interface Connector

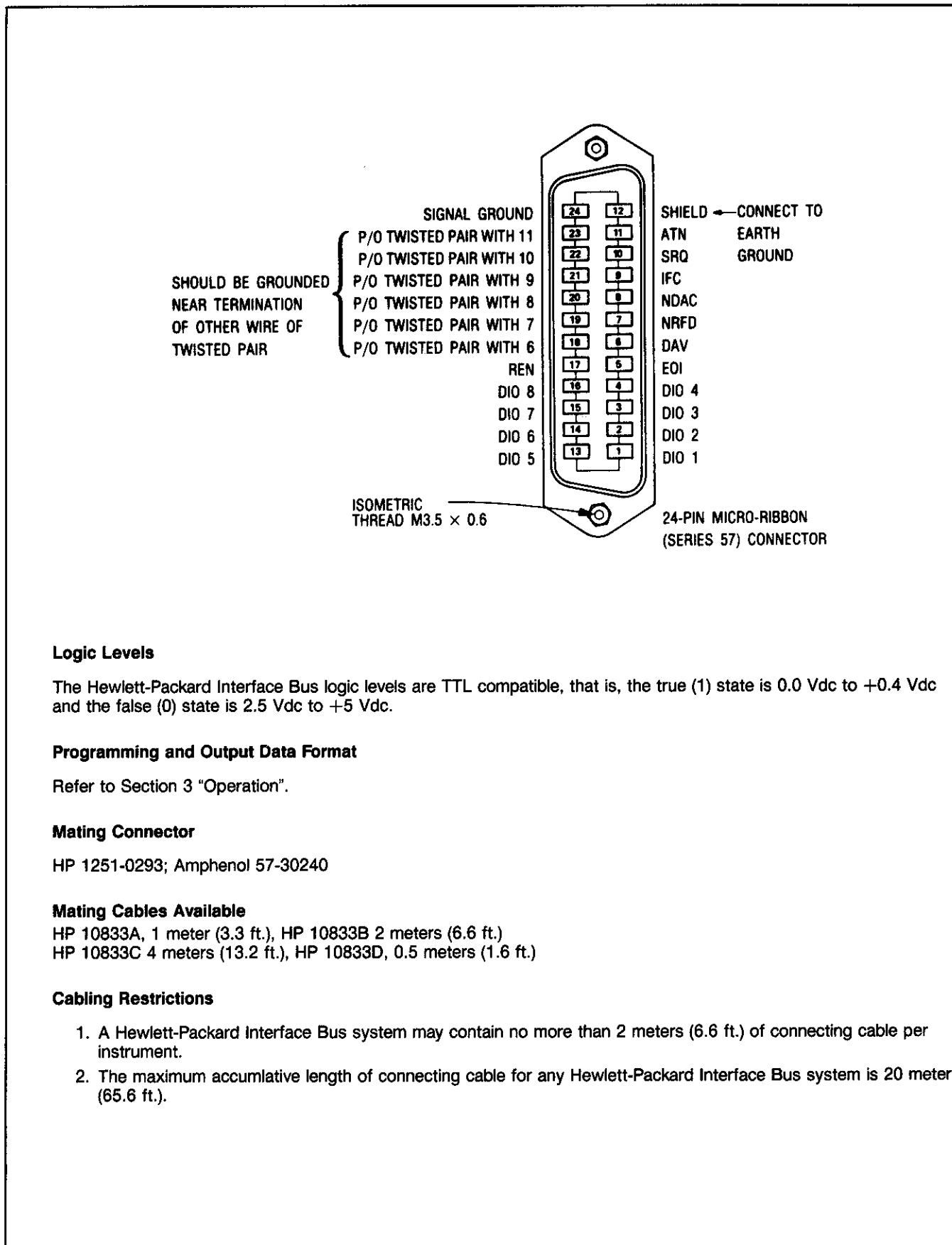

Logic Levels

The Hewlett-Packard Interface Bus logic levels are TTL compatible, that is, the true (1) state is 0.0 Vdc to +0.4 Vdc and the false (0) state is 2.5 Vdc to +5 Vdc.

Programming and Output Data Format

Refer to Section 3 "Operation".

Mating Connector

HP 1251-0293; Amphenol 57-30240

Mating Cables Available

HP 10833A, 1 meter (3.3 ft.), HP 10833B 2 meters (6.6 ft.)
 HP 10833C 4 meters (13.2 ft.), HP 10833D, 0.5 meters (1.6 ft.)

Cabling Restrictions

1. A Hewlett-Packard Interface Bus system may contain no more than 2 meters (6.6 ft.) of connecting cable per instrument.
2. The maximum accumulative length of connecting cable for any Hewlett-Packard Interface Bus system is 20 meters (65.6 ft.).

Figure 2-2. AC Power Cables Available (P/O ERRATA)

2-14. Packaging

Original Packaging. Containers and materials identical to those used in factory packaging are available through Hewlett-Packard Offices. If the instrument is being returned to Hewlett-Packard for servicing, attach a tag indicating the type of service required, return address, model number, and full serial number. Also mark the container FRAGILE to assure careful handling. In any correspondence refer to the instrument by model number and full serial number.

Other Packaging. The following general instructions should be used for repackaging with commercially available materials:

- a. Wrap the instrument in heavy paper or plastic. (If shipping to a Hewlett-Packard Office or service center, attach a tag indicating the service required, return address, model number, and full serial number.)
- b. Use a strong shipping container. A double-wall carton made of 2.4 MPa (350 psi) test material is adequate.
- c. Use enough shock absorbing material (75 to 100 mm layer—3 to 4 inches) around all sides of the instrument to provide firm cushion and prevent movement in the container. Protect the control panel with cardboard.
- d. Seal the shipping container securely.
- e. Mark the shipping container FRAGILE to ensure careful handling.

Table 2-3. Decimal Address Codes

Decimal Equivalents	ASCII Address Codes	
	LISTEN	TALK
00	SP	©
01	!	A
02	"	B
03	#	C
04	\$	D
05	%	E
06	&	F
07	'	G
08	(H
09)	I
10	.	J
11	+	K
12	,	L
13	-	M
14	.	N
15	/	O
16	0	P
17	1	Q
18	2	R
**19	3	S
20	4	T
21	5	U
22	6	V
23	7	W
24	8	X
25	9	Y
26	::	Z
27	:::	[
28	<	\
29	=]
30	v	^

*Indicates factory set address.

Section 3 OPERATION

3-1. INTRODUCTION

This section explains the operating characteristics of the signal generator, its function, controls and modes of operation. It explains operator checks and maintenance (the OVEN fuse replacement is the only maintenance recommended in this section).

3-2. Operating Characteristics

The signal generator can produce fixed or swept frequency signals between 100 kHz and 2560 MHz, between +16 and -129.9 dBm, with AM, FM, Φ M, PULSE, BPSK or mixed modulation.

The generator can be controlled by the front panel, or by the HP-IB and to a limited extent, by the rear panel AUX connector. All value selectable parameters can be varied in steps by the INCREMENT keys and the knob.

There are nine internal registers for storing and recalling full, front-panel configurations.

3-3. Local Operation

General Operation. Several instructions relating to all features and modes are presented in paragraph 3-7, "General Operating Instructions".

Operating Information Card. The pull-out "Operating Information" card, located underneath the generator, presents general operating instructions. With examples of most of the generator's features, it is a good teaching aid as well as a quick reference.

Detailed Operating Instructions. The detailed operating instructions present the most comprehensive information about all the generator's functions. The instructions are arranged alphabetically by title. They are indexed by function in Table 3-1.

Panel Features. Front and rear panel features are described in Figures 3-1 and 3-2.

3-4. Remote Operation

HP-IB. Knowledge of local operation is essential for HP-IB programming since most of the data messages contain the same keystroke-like sequences. HP-IB information is presented in the following areas:

- General HP-IB instructions begin in paragraph 3-15.
- Detailed information on the generator's operational features (with tables and examples of related program codes) is presented in the detailed operating instructions (refer to the index in Table 3-1).

Auxiliary. A limited amount of front-panel keyboard functions can be controlled through the rear-panel AUX connector. Refer to paragraph 3-12 for the description of the AUX connector configuration.

3-5. Operator's Checks

This section normally includes checks that allow the operator to make a quick evaluation of the Generator's operation. The HP 8663A Signal Generator however, contains self-diagnostic hardware and software that will alert the operator in the event of a major instrument malfunction. Refer to the detailed operating instruction entitled "STATUS" for related information.

3-6. OVEN FUSE REPLACEMENT

Two fuses on the rear panel are labeled "LINE" and "OVEN". If either fuse opens, the entire generator would be disabled. The operator should only replace the OVEN fuse.

WARNING

For continued protection against fire hazard, replace only with a 250V, normal blow fuse with the same current rating.

CAUTION

The casual operator should not replace the LINE fuse. Replacing this fuse in a damaged Generator might cause additional damage. A qualified service person should first determine the cause of its failure, specifically with resistance checks in the power supply (refer to Service Sheet 65); repair the failure and then replace the fuse.

Fig 3-1 SH-1 of 3

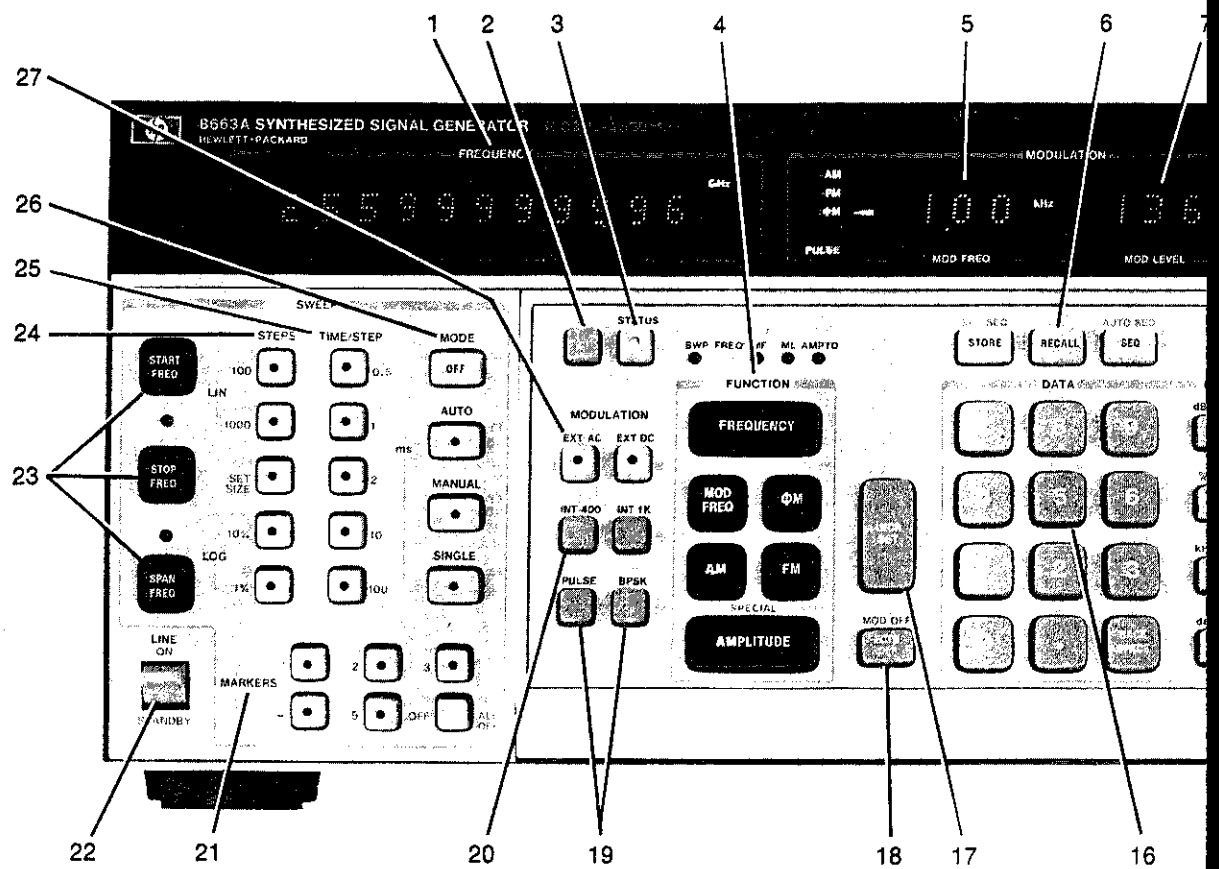

Figure 3-1. Front Panel Features

Fig 3-1 Sht 2 of 3

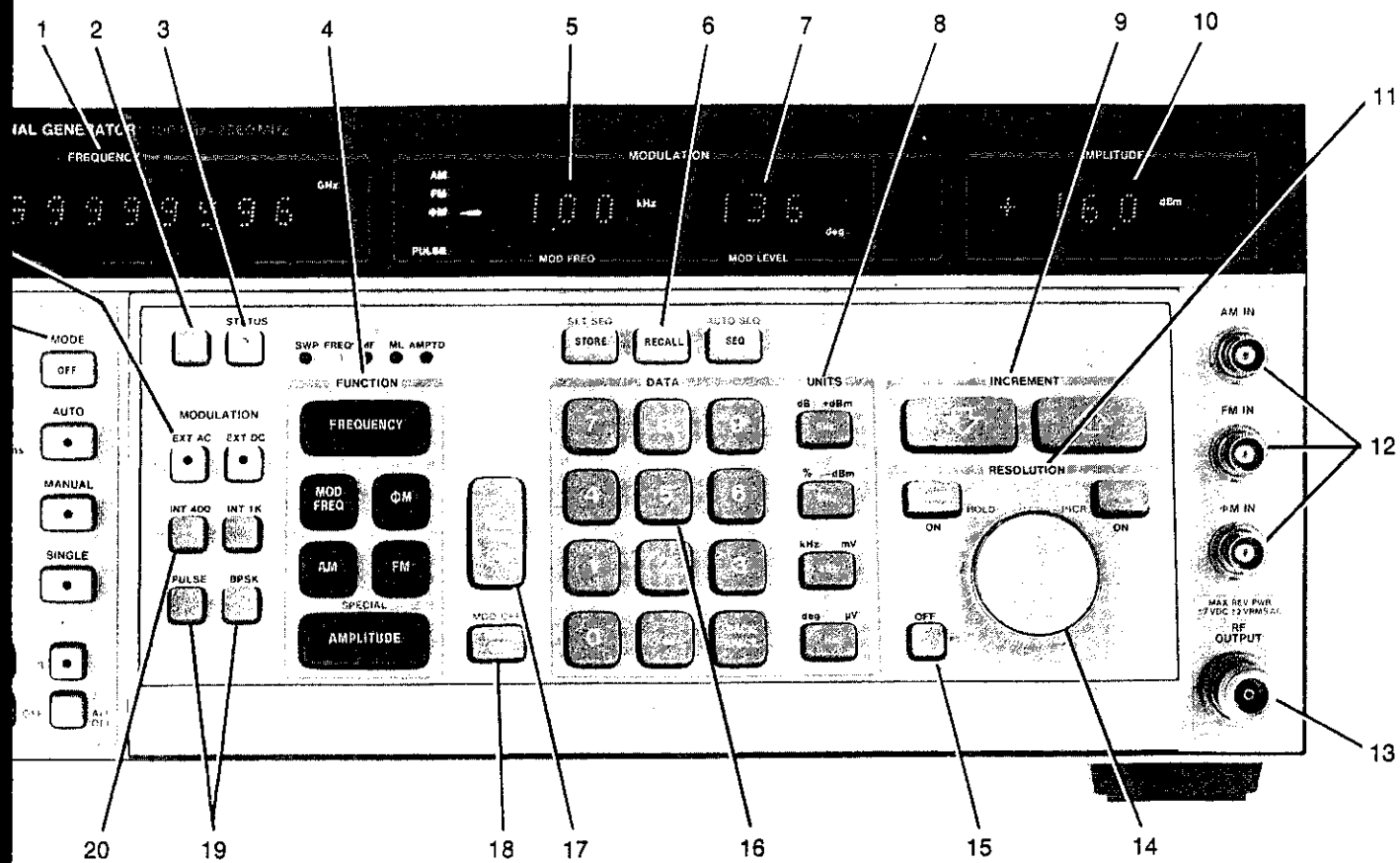

Figure 3-1. Front Panel Features

Fig 3-1 Sht 3 of 3

Model 8663A

To replace the OVEN fuse, first set the LINE switch to STANDBY and unplug the power cable. Then remove the fuse cap and replace the fuse. Values for the fuse are printed below the fuseholder. The HP part numbers are listed in Section 2 (Installation).

3-7. FRONT AND REAR-PANEL

The front-panel of the HP 8663A Signal Generator is shown in Figure 3-1. It is followed by a simplified operation describing basic operations such as setting frequency, modulation and modulation frequency, changing the set values using the increment key or knob, and setting the sweep parameters.

Table 3-1 contains a list of the detailed operating instructions and their page numbers. The detailed operating instructions should be referenced whenever more information on any of these functions is needed.

The rear-panel of the HP 8663A Signal Generator is shown in Figure 3-2. The rear-panel diagram shows a standard instrument.

-
1. **FREQUENCY.** Displays RF frequency parameters. Other data can be displayed: Special Functions, Error Codes, Sequence, Step-Delay and Sequence Recall-order.
 2. **BLUE KEY.** Allows entry of either special or shifted functions. Used in displaying hardware status codes and with the "Frequency Copying" function.
 3. **STATUS.** Indicates malfunctions, entry errors and other significant conditions. Press and hold to display instrument status.
 4. **FUNCTION.** Enable entry of basic signal generator parameter values.
 5. **MOD FREQ.** Displays frequency value of the signal generator's modulation oscillator.
 6. **STORE/RECALL/SEQUENCE.** Allows storage and recall of full front-panel configurations.
 7. **MOD LEVEL.** Displays AM depth, FM or Φ M deviation.
 8. **UNITS.** Select units for last-selected, front panel function.
 9. **INCREMENT.** Changes value of last-selected, front-panel function in increments determined by the INCR SET key.
 10. **AMPLITUDE.** Displays RF level.
 11. **RESOLUTION.** Changes resolution of Knob by a factor of ten with each keystroke.
 12. **AM/FM/PM IN.** Ac- or dc-coupled inputs for external modulation signal sources.
 13. **RF OUTPUT.** Output signal 100 kHz to 2560 MHz, +16 dBm to -129.9 dBm.
 14. **KNOB.** Changes value of last-selected, front-panel function in steps determined by the RESOLUTION (times-ten, divide-by-ten) keys. Shifted divide-by-ten key enables the knob to change parameter in increments determined by the INCR SET key.
 15. **KNOB OFF.** Turns knob function off.
 16. **DATA.** Select value for the last-selected, front-panel function.
 17. **INCR SET.** Select the increment step-size for the INCREMENT keys or Knob.
 18. **FCTN OFF.** Turns off last-selected, front-panel function.
 19. **PULSE/BPSK.** Select either Bi-Phase Shift Keying or Pulse modulation modes.
 20. **INT 400/INT 1K.** Select internal fixed frequency (400 Hz or 1 kHz).
 21. **MARKERS.** Set marker frequencies and turn markers on.
 22. **LINE.** Turns on full power. In STANDBY, the reference oscillator oven is energized.
 23. **START-STOP/SPAN.** Determines RF or modulation frequency sweep limits.
 24. **STEPS.** Select the number of steps in the RF or modulation staircase sweep.
 25. **TIME/STEP.** Set the time interval between sweep steps.
 26. **MODE.** Select one of three sweep modes. MANUAL sweep is controlled by the knob.
 27. **MODULATION EXT AC/EXT DC.** Select ac- or dc-coupling for external modulation source.
-

SIMPLIFIED OPERATION

BASIC SIGNAL GENERATOR FUNCTIONS

RF FREQUENCY is set by selecting FREQUENCY, Data and Units.

RF OUTPUT AMPLITUDE is set by selecting AMPLITUDE, Data and Units.

MODULATION

MODULATION LEVEL is set by selecting Modulation type, Data and Units.

MODULATION FREQUENCY is set by selecting MOD FREQ, Data and Units.

STORE/RECALL/SEQUENCE

The Generator can store control settings for recall at a later time. These capabilities are discussed in detailed operating instructions entitled "STORE-RECALL" and "SEQUENCE".

STATUS

Entry errors, hardware malfunctions and other significant conditions are indicated by the lighted STATUS key. A two-digit code will appear at the far right of the FREQUENCY display when the STATUS key is pressed and held down. Status code descriptions can be found on the Generator's pull-out information card or in the detailed operating instruction entitled "STATUS".

SIMPLIFIED OPERATION

CHANGING VALUES

A parameter's value can be changed by: A new Function-Data-Units entry, by the use of the INCREMENT keys, or by using the knob.

INCREMENT a parameter by selecting a Function, then either the INCREMENT UP or the INCREMENT DN key.



INCR SET allows the increment step-size of a parameter to be entered by selecting a Function, INCR SET, Data and Units.

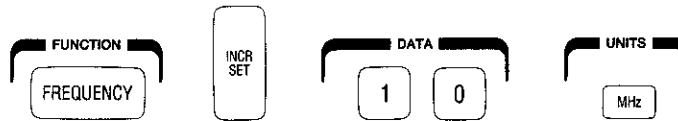

KNOB can be used to control the value of a specific function by selecting a Function key and times-ten or divide-by-ten.

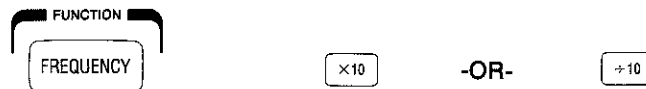

If the times-ten or the divide-by-ten key is pressed and held down, the knob resolution will increase or decrease by a factor of ten upon each keystroke.

KNOB ROTATION clockwise or counterclockwise, increments parameter value in unit steps; incrementing begins at the digit designated as the knobs resolution.

The knob is disabled by selecting the OFF key or by selecting a new function.

SWEEP FUNCTIONS

The Generator has the capability to sweep its RF or modulation signal in discrete steps.

START/STOP FREQUENCY values determine where the RF sweep will begin and end.

START frequency is set by selecting START FREQ, Data and Units.

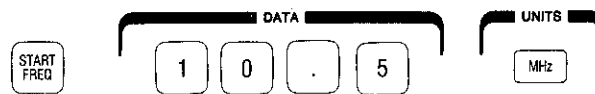

STOP frequency is set by selecting STOP FREQ, Data and Units.



STEPS allows selection of the increment step-size for FREQUENCY when in the sweep mode.

TIME/STEP sets the time interval between sweep steps.

MODE keys can select a continuous sweep (AUTO), manual sweep (controlled by the knob) or single sweep.

MARKER frequencies are set by selecting the desired MARKER, Data and Units.



SIMPLIFIED OPERATION**SPECIAL FUNCTIONS**

Special Functions extend the keyboard capability, however, these functions are not labeled on the front panel. Refer to the Generator's pull-out information card or to the detailed operating instruction entitled "Special Functions" for descriptions of these functions.

Table 3-1. Index of Detailed Operating Instructions

Instruction	Page	Instruction	Page
ALC Bandwidth Reduction	3-17	Modulation, Internal AM	3-66
Amplitude	3-18	Modulation, External AM	3-69
Amplitude Conversion (V → dBm)	3-20	Modulation, Internal FM	3-71
Amplitude Correction	3-21	Modulation, External FM	3-74
Amplitude Correction, RF Sweep Mode	3-23	Modulation, External AUX FM	3-77
Amplitude Reference	3-25	Modulation, Internal Φ M	3-79
Amplitude, Manual Level-Control	3-27	Modulation, External Φ M	3-81
Amplitude, Microvolt Reference	3-30	Modulation, Pulse	3-83
Frequency	3-32	Modulation, BPSK	3-85
Frequency Copying	3-34	Modulation, Mixed	3-87
Frequency Hopping	3-36	Modulation, Oscillator	3-89
Frequency Offset	3-38	Modulation Sweep	3-91
HP-IB Address Display	3-40	Modulation Sweep Modes	3-93
HP-IB Execution Modes	3-41	Modulation Sweep, Span	3-95
HP-IB "Fast" Learn Mode	3-42	Modulation Sweep, Start-Stop	3-97
HP-IB Front-Panel Learn Mode	3-44	Modulation Sweep, Step Size	3-99
HP-IB Remote Stepped Sweep	3-46	Modulation Sweep, Time/Step	3-101
HP-IB Request Service (RQS) Mask	3-48	RF Sweep	3-102
HP-IB Status Byte	3-50	RF Sweep Modes	3-104
HP-IB STATUS Key Message	3-52	RF Sweep Markers	3-106
HP-IB Trigger Response	3-53	RF Sweep Span	3-108
Increment UP DN	3-54	RF Sweep, Start-Stop	3-110
Increment Setting	3-55	RF Sweep, Time/Step	3-112
Increment, Parameter Shift Keying	3-57	RF Sweep, Step Size	3-113
Knob	3-59	Sequence	3-116
Knob Hold	3-61	Sequence, Step-Delay	3-118
Knob Increment	3-62	Special Functions	3-120
Knob Increment/Revolution	3-64	Status	3-124
Memory Check	3-115	Store-Recall	3-128
		System Clear	3-130

Fig 3-2 Sht 1 of 3

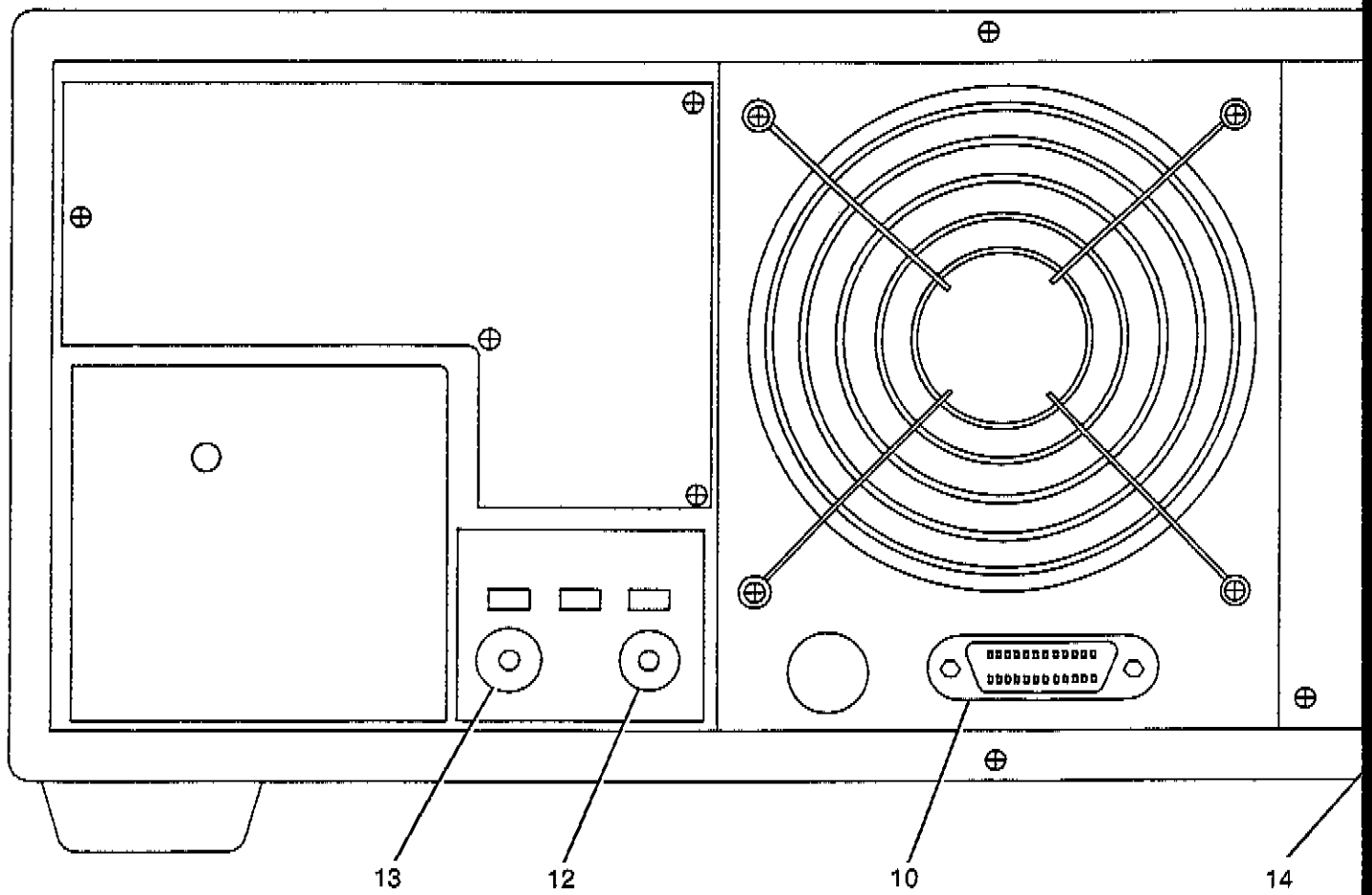
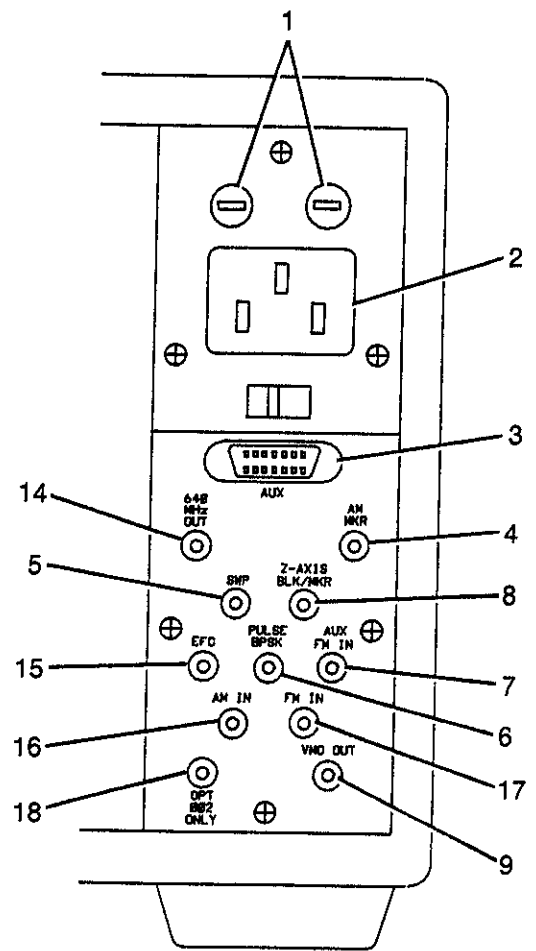
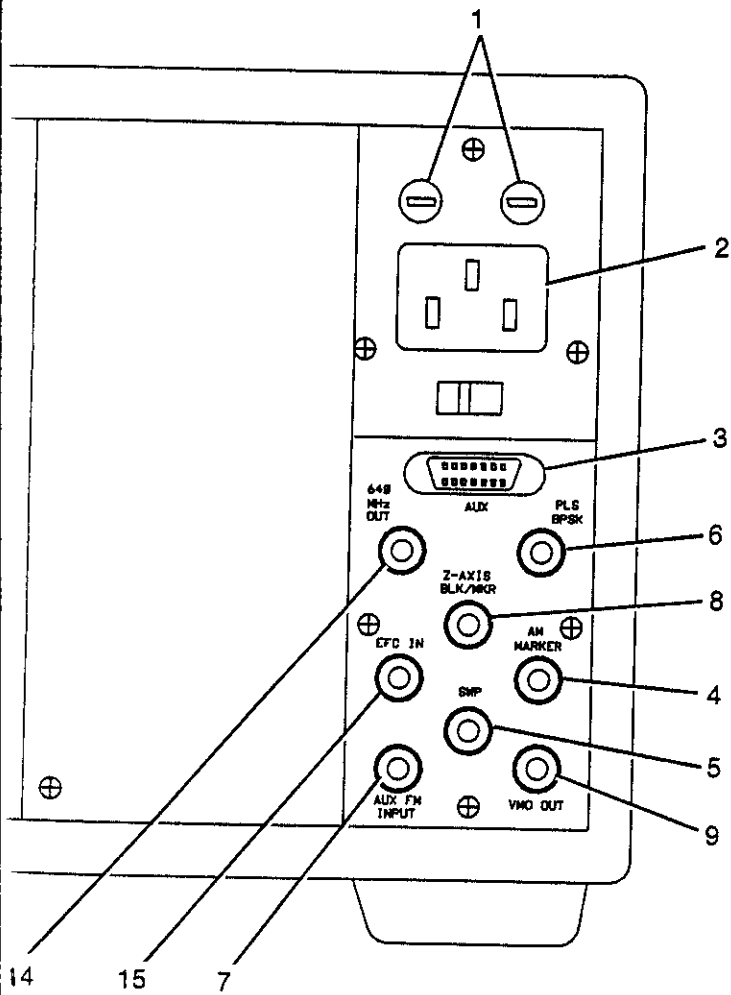

Figure 3-2. Rear P

Fig 3-2 SHt 2 of 2



OPT 001

Fig 3-2
Shd 3 of 3

WARNING

Plate with warning designations protects the Signal Generator's line voltage wiring and associated components. This plate should only be removed by service-trained personnel who are aware of the potential shock hazard.

Long hair can be drawn into the fan causing personal injury.

1. **OVEN/LINE FUSE.** OVEN fuse for reference oscillator oven and the Generator's auxiliary power supply. The entire Generator is disabled when this fuse is opened. It must be selected for 115V or 230V operation. Ordering information for this fuse is presented in Section 2, Installation.

LINE fuse will disable the entire instrument if it is opened. This fuse must be selected for 115V or 230V operation. The LINE fuse should not be replaced until the cause of its failure has been determined.
2. **LINE Cord Receptacle.** The center contact of this receptacle is connected to the Generator's chassis. Available power cables are described in Section 2, Installation.

115V-230V Switch must be selected for available line voltage.
3. **AUX Connector.** Connector consists of six TTL inputs for limited remote control of front-panel functions. There are three TTL outputs which indicate the Generator's processing status. Refer to paragraph 3-12 for more detailed information.
4. **AM MARKER.** Output impedance is ≈ 1 k ohms, 5 kHz triangle wave, 3 Vpp. Can be applied to the AM IN modulation input connector to provide adjustable AM markers.
5. **SWEEP.** The SWP output connector on the rear panel provides a 0 to +10V staircase that can be used to drive a swept display (maximum of 10,000 steps). Staircase sweep is synchronized with the RF or modulation sweep.
6. **PLS BPSK.** Connector allows input of external PULSE or BPSK modulation signal.
7. **AUX FM IN.** Connector allows input of external FM modulation signal. Input impedance ≈ 5 k ohms and is dc coupled. Refer to detailed operating instruction entitled "Modulation, External AUX FM".
8. **Z-AXIS BLANKING/MARKER.** A blanking pulse (TTL high-level, 250 μ s duration) is produced at the beginning of each step of the staircase sweep.

A marker pulse (-5V pulse) is produced at the point of a selected marker frequency (-5V is nominal; it is internally adjustable between -2 and -8V).

Refer to detailed operating instruction entitled "RF Sweep".
9. **VMO OUT.** The VMO OUT connector outputs the Generator's modulation oscillator signal. Output 1 Vpk into 600 ohms. Output impedance ≈ 600 ohms.
10. **HP-IB REMOTE CONTROL.** Connects the Generator to the Hewlett-Packard Interface Bus for remote operation.
11. **OPTIONAL RF OUTPUT.** (Option 001 only). Nominal impedance is 50 ohms. Output level is +16 to -129.9 dBm.
12. **EXTERNAL REFERENCE.** Switched input for external 5 or 10 MHz reference. Input impedance is 50 ohms.
13. **INTERNAL REFERENCE.** 10 MHz reference output. Output impedance is 50 ohms. Output signal is derived from the selected reference.
14. **640 MHz OUT.** A 640 MHz reference output used in phase noise applications. Performance is specified for Option 003 only.
15. **EFC IN.** Input for frequency control of the 10 MHz reference oscillator. +10 Vdc to -10 Vdc gives a 1 Hz change in frequency.
16. **AM IN.** (Option 001 only) AC or DC coupled input for AM modulation.
17. **FM IN.** (Option 001 only) AC or DC coupled input for FM modulation.
18. **PM IN.** (Option 001 only) AC or DC coupled for phase modulation.

3-8. GENERAL OPERATING INSTRUCTIONS

WARNING

Before the instrument is switched to on, all protective earth terminals, extension cords, auto-transformers and devices connected to it should be connected to a protective earth grounded socket. Any interruption of the protective earth grounding will cause a potential shock hazard that could result in personal injury.

Only 250V normal blow fuses with the required rated current should be used. Do not use repaired fuses or short circuited fuseholders. To do so could cause a shock or fire hazard.

When working near the back of the Generator, take care not to let long hair be drawn into the fan. This could result in personal injury.

CAUTION

Before the instrument is switched on, it must be set to the voltage of the power source, or damage to the instrument may result.

Turn-on

Turn-on Procedure. The Generator has a STANDBY state and an ON state. Whenever the power cable is plugged in, the instrument's oven is energized to keep the reference oscillator stable. If the Generator is already plugged in, set the POWER switch to ON.

If the power cable is not plugged in, follow these instructions:

1. Check the line voltage switch for correct voltage selection.
2. Check the two fuses for correct current ratings. Current ratings are printed on the rear panel.
3. Plug in the power cable.
4. Set the front-panel POWER switch to ON.

NOTE

The light in the STATUS key should turn on blinking to indicate that the Generator requires warming up. (Status Code 12). The light should turn off within one hour and the Generator should be ready for general use.

Turn-on Configuration. The Generator turns on to the same control settings it had before it was switched to STANDBY or even completely OFF (that is, if line power was removed). The exceptions to this rule are listed below.

- It always turns on to local mode (vice HP-IB remote).
- It always turns on with the auto-sequence mode disabled.
- HP-IB default conditions are enabled. These are described in paragraph 3-21 under "Turn-on Default Conditions".

Turn-on Memory Check. The Generator performs a quick memory check at turn-on. It checks for a failure in ROM (permanent memory) or in RAM (temporary memory), and for the presence of correct data stored in RAM. Also refer to the operating instruction entitled "Memory Check".

NOTE

An internal battery is used to retain data in RAM during standby and off periods. The data restores the last control setup and the nine storage registers.

The check takes less than five seconds and occurs while the Generator's readout displays all dashes.

If a ROM or serious RAM failure occurs the Generator will attempt to turn on to its last control setup. The Generator might be useable but does require service (malfunction code 99 will be set in the status readout).

If all of the register data has been altered (for example, if the battery failed) the Generator will initialize to 100 MHz, -30 dBm, modulation, sweep and special functions off. The initialized control setup will then be stored in all of the registers. The Generator might be useable but does require service (code 53 will be set in the status readout).

NOTE

The Parameter Out line (pin 12) on the rear panel AUX connector will switch to and remain at a TTL-low level when this condition occurs. Thus it can be used to indicate that the Generator turned on to an unexpected state.

If any, but not all, of the stored data is found to be incorrect, the Generator will turn on to the configuration stored in its first good register. This could be caused by even a single bit of data being lost due to line transients, noise or other unpredictable

conditions. The Generator should be useable and does not require service unless this situation occurs repeatedly (code 52 will be set in the status readout).

NOTE

In this situation, special functions and markers would also be cleared and the sequence reset to 1-2-3-4.

If the Generator is being used in a situation where its turn-on configuration is critical, it should have that configuration stored in all of the registers (without the use of special functions, markers or sequence).

3-9. Reference Selection

Three reference signal switches and two connectors are located on the rear panel. The INPUT connection can accept a reference signal to be used instead of the Generator's internal reference.

The internal reference is a 10 MHz signal with an aging rate of $< (5 \times 10^{10})/\text{day}$ after warm-up (typically after 24 hours). Pressing the INT switch enables this internal reference.

Pressing either EXT switch disables the internal reference and enables the INPUT connector for signals of 5 MHz at >13 dBm or 10 MHz at >7 dBm. The OUTPUT connector provides a 10 MHz signal (>7 dBm) derived from the selected reference. The OUTPUT connector does not require any switching.

3-10. Status Messages

The Generator produces several messages that indicate its status. The messages are in numeric codes which are described on the pull-out Operating Information card, and in the detailed operating instructions entitled "Status". The messages appear in the FREQUENCY read-out when the STATUS key is pressed (special functions on the left; entry errors, hardware malfunctions and general status on the right).

The light in the STATUS key turns on to signal the operator that an entry error, hardware malfunction or other significant condition exists that affects operation. The light does not turn on for special functions.

3-11. Amplitude Correction

The Generator achieves optimum, output level accuracy by correcting for internal amplitude variations throughout its frequency range. Much of this correction involves switching of the output attenuator. The exception is when the Special Function 87 is enabled

and an RF sweep is being executed. Thus, it is possible for the attenuator to receive excessive mechanical wear during long periods of automatic frequency changes (for example, during operations that involve auto-sequencing, HP-IB controlled frequency switching, low-rate FM, etc).

If the high degree of level accuracy is not required during these operations, the correction feature should be defeated with the Special Function 85.

NOTE

The normal amplitude correction feature is disabled when an RF sweep mode is executed.

Specified level accuracies (with correction enabled) and typical accuracies (with correction disabled) are listed in the detailed operating instruction entitled "Amplitude Correction".

3-12. REMOTE OPERATION, AUXILIARY CONTROL

3-13. AUX Input Lines

A limited number of front panel functions can be controlled through the rear panel AUX connector. These functions are listed in the table below.

The input lines are TTL compatible and negative-edge sensitive. They require a minimum of $5 \mu\text{s}$ between negative edges. Input signals can be generated by clean TTL drivers or by mechanical switches that require debouncing. The Generator has a built-in debouncing circuit that should be enabled or disabled depending upon which type of control is used.

The Generator is shipped from the factory configured for electrically-clean control signals (that is, the debouncing circuit is disabled). One way to determine if the debouncing circuit is still disabled is described below.

- Set any of the front-panel parameter's increment value to one (1).
 - Ground pin 2 (Step Up) several times and observe the parameter change.
 - If the parameter steps are erratic (for example, steps of 2, 4, 3, etc.), the debouncing circuit is still disabled.
 - If the parameter consistently changes in steps of one, the debouncing circuit is enabled.
- Refer to Section II (Installation) for the procedure for enabling or disabling the debouncing circuit.

NOTE

The Installation section also shows the pin-out configuration of the AUX connector as well as information for a recommended mating connector.

3-14. AUX Output Lines

The AUX connector also has a ground line and three TTL compatible output lines. The output lines are normally held at a TTL-high level. The Sweep End line produces one 5 us low-going pulse at the end of each sweep. The Pen-Lift line outputs a TTL high-level for a pen-up condition and a low-level for a pen-down condition (Single sweep mode only). The Parameter Out line produces one 5 us low-going pulse when any signal parameter changes.

The Parameter Out line also goes low and remains low if the Turn-On Memory Check produces error code 53. This feature can be used to signal an unexpected turn-on configuration. The line is reset the first time an instrument parameter changes.

The Auxiliary connector Mode 1 configuration is the connector's normal operating state. The Mode 2

configuration is enabled by Special Function 91 (Frequency Hopping function).

3-15. REMOTE OPERATION, HEWLETT-PACKARD INTERFACE BUS

The Generator can be operated through the Hewlett-Packard Interface Bus (HP-IB). Bus compatibility, programming and data format are described in the following paragraphs and in the detailed operating instructions.

All front panel functions (except for that of the POWER switch), special functions and remote-only functions are programmable through the HP-IB.

For more information about HP-IB, refer to IEEE Std 488 (or the identical ANSI Standard MC1.1), the Hewlett-Packard catalog and the booklet "Improving Measurements in Engineering and Manufacturing" (HP part number 5952-0058).

3-16. HP-IB Compatibility

The Generator's complete bus compatibility as defined in IEEE 488 (or the identical ANSI Standard MC1.1) is presented beneath Table 3-4.

Table 3-2. Mode 1 AUX Connector Functions

	Pin	Function	Description
INPUTS	2*	Step Up	Same as INCREMENT (↑) key
	3*	Step Down	Same as INCREMENT (↓) key
	4	Stop Sweep	Same as MANUAL sweep mode key
	5	Continue Sweep	Same as AUTO sweep mode key
	6	Single Sweep	Same as SINGLE sweep mode key
	7	Sequence	Same as SEQ key
OUTPUTS	1	Sweep End	One pulse at end of each sweep.
	9	Pen Lift	TTL high level for pen-up, TTL low level for pen-down. Single sweep mode only.
	12	Parameter Out	One pulse whenever Generator's signal parameter changes. Low if Generator encounters unexpected turn-on state.

*Special Function 95 defines pin 2 as Knob Clockwise and pin 3 as Knob Counterclockwise.

Table 3-3. Mode 2 AUX Connector Functions

Pin	Function	Description
2	Hop to Frequency 1.	Recalls RF frequency in Register 1.
3	Hop to Frequency 2.	Recalls RF frequency in Register 2.
4	Hop to Frequency 3.	Recalls RF frequency in Register 3.
5	Hop to Frequency 4.	Recalls RF frequency in Register 4.
6	Hop to Frequency 5.	Recalls RF frequency in Register 5.
7	Hop to Frequency 6.	Recalls RF frequency in Register 6.
12	Parameter Out	One pulse whenever Generator's signal parameter changes. Line remains low if Generator encounters an unexpected turn-on configuration.

Table 3-4. HP-IB Message Reference Table

HP-IB Message	Applicable	Response	Related Commands and Controls*	Interface Functions*
Data	Yes	All front panel functions, special functions and remote only functions are programmable. The Generator can send STATUS key information, the Request Service Mask value and control setups (learn modes). The front panel ADDRESSED indicator turns on when addressed.		T6 L3 AH1 SH1
Trigger	Yes	Executes a previously selected program code. Responds equally to bus command GET and program code TR (a Data Message).	GET	DT1
Clear	Yes	Sets output to 100 MHz, -30 dBm with modulation and sweep off. Resets many additional parameters as shown on page 3-167. Responds equally to DCL and SDC bus commands.	DCL SDC	DC1
Remote	Yes	The Generator's remote mode is enabled when the REN bus line is true. However, it remains in local (i.e., the keyboard is active) until it is addressed to listen the first time. The output signal is unchanged. The front panel REMOTE indicator turns on when in remote mode and after receiving its first Data Message.	REN	RL1
Local	Yes	The Generator returns to front panel control. The output signal is unchanged. Responds equally to the GTL bus command and the front panel Blue Key.	GTL	RL1
Local Lockout	Yes	Blue key is disabled. Only the controller can return the Generator to local.	LLO	RL1
Clear Lockout/ Set Local	Yes	Generator returns to local when the REN bus line goes false.	REN	RL1
Pass Control/ Take Control	No	The Generator has no controller capability.		C0
Require Service	Yes	The Generator sets the SRQ bus line true if one of the following conditions exists and it has been enabled by the RQS mask to send the message for that condition: Ready, Entry Error, Hardware Error, Power Fail Restart, Parameter Out, Sweep End and Operator Requests Response (SP-87).	SRQ	SR1
Status Byte	Yes	The Generator responds to a Serial Poll Enable (SPE) bus command by sending an 8-bit byte. Bit 7 (RQS bit) is true if Generator had sent the Request Service Message. All bits except bit 1 are latched and must be cleared. Each bit requires different conditions for clearing. See page 3-71 for details.	SPE SPD	T6
Status Bit	No	The Generator does not respond to a parallel poll.		PP0
Abort	Yes	The Generator stops talking or listening.	IFC	T6, L3

*Commands, Control lines and Interface Functions are defined in IEEE Std. 488 (and the identical ANSI Standard MC1.1). Knowledge of these might not be necessary if your controller's manual describes programming in terms of the twelve HP-IB Messages shown in the left column.

Complete HP-IB capability as defined in IEEE Std. 488 (and the identical ANSI Standard MC1.1) is:
SH1, AH1, T6, TE0, L3, LE0, SR1, RL1, PP0, DC1, DT1, C0.

3-17. HP-IB Messages

The programming capability of the Generator is further described by the twelve HP-IB messages in Table 3-4. Foremost among these messages is the Data message. Data messages contain the program codes that control the Generator's output signal.

3-18. Remote Mode

Remote Capability. The Generator communicates on the bus in both remote and local modes. In remote, its front panel controls are disabled (except for the POWER switch, the Blue Key, the STATUS key and the function keys for displaying "hidden" parameters). The Generator can be addressed to listen or talk. When addressed to listen, the Generator will automatically stop talking and respond to the following messages: Data, Trigger, Clear, Remote, Local, Local Lockout, Clear Lockout/Set Local and Abort. When addressed to talk, the Generator will automatically stop listening and send one of the following messages: Data, Request Service or Status Byte.

NOTE

When the instrument is in the remote mode, the keyboard is functionally disabled; however, the STATUS and function keys can interrupt certain Generator operations thus delaying the generator's processing of program steps.

Local-to-Remote Change. The Generator switches to remote upon receipt of the Remote message. The Remote message has two parts. They are:

- Remote-enable (REN)
- Addressed-to-Listen once

The Generator's output signal and all control settings remain unchanged with the Local-to-Remote transition.

3-19. Local Mode

Local Capability. In local, the Generator can send a Require Service message, send a Status Byte message and respond to the Remote message.

NOTE

By strict definition, the Generator can respond to all HP-IB messages except the Data Message while in local. However, most of these messages would not normally be used in the local mode.

Remote-to-Local Change. The Generator returns to local control upon receipt of the Local or Clear Lockout/Set Local message. It can also be set to local mode by pressing the front-panel Blue Key (assuming that local lockout is not in effect). The Generator's output signal remains unchanged and all preselected functions remain unchanged with the remote-to-local transition.

Local Lockout. When a data transmission is interrupted, which can happen by returning the Generator to local with the Blue Key, the data could be lost. This would leave the Generator in an unknown state. To prevent this, a local lockout is recommended. Local lockout disables the Blue Key and allows return-to-local only under program control.

NOTE

Return-to-Local can also be accomplished by turning the Generator to Standby, then on again. However, this technique has several potential disadvantages.

- It defeats the purpose and advantages of local lockout (that is, the system controller will lose control of a system element).
- There are several HP-IB conditions that reset to default states at turn-on.

3-20. Addresses

The Generator's Talk and Listen addresses are set by a set of thumbwheel switches located inside the instrument. The address selection procedure is described in Section II. This information is intended for service trained persons who are aware of the potential shock hazard of working on an instrument with protective covers removed.

To display the Generator's current HP-IB address, refer to the detailed operating instruction entitled "HP-IB Address Display".

3-21. Turn-on Default Conditions

Several HP-IB parameters are reset at turn-on. The parameters and their default conditions are listed below:

- HP-IB Local Mode.
- Immediate Execution Mode. (Refer to operating instruction entitled "HP-IB Execution Modes.")
- Talk and Listen addresses set to internal switch setting.
- Unaddressed.

- Remote Stepped Sweep off.
- Trigger configuration.

3-22. Displays

The REMOTE light is on when the Generator is in the remote mode and after it has received its first Data message. The ADDRESSED light is on when the Generator is currently addressed to talk or listen.

The conditions which will cause a STATUS Message to be set are the same in both remote and local. The STATUS message can be read in either remote or local when the Generator is under program control. For further discussion of STATUS, refer to the operating instructions entitled "HP-IB Status Key Message" or "STATUS". The three major parameter readouts (FREQUENCY, MODULATION and AMPLITUDE) operate identically in the remote mode as in local. Hidden parameters can still be displayed by their front-panel keys. (This capability is not available to the controller since no program code equivalent to pressing and holding a key down.)

3-23. Receiving Data Messages

The Generator communicates on the HP-IB primarily with Data messages. Data messages include the Generator's HP-IB program codes (which are defined in Tables 3-4 and 3-5). The program codes contain information for programming front-panel functions (with the exception of the LINE switch), all special functions and remote-only functions.

The Generator will respond to Data messages when in remote and addressed to listen.

Data Message Input Format. Data messages contain the controller's Talk address, the Generator's Listen address, a string of program codes and an End-of-String message (EOS). The string of program codes follows the same protocol as keystrokes at the front panel. EOS can be a Line Feed (LF), an exclamation mark (!), a bus END message (i.e., EOI and ATN true) or an internally produced EOS (refer to the operating instruction entitled "HP-IB Execution Modes").

The following paragraphs explain other key elements of the program code strings. Figure 3-3 shows several examples of Data Messages.

Keyboard-Program Code Correlation. There is a corresponding HP-IB program code for every key-label printed on the front panel. These program codes appear adjacent to their respective key.

Value-Selectable Parameters. Parameters, such as FREQUENCY and AMPLITUDE are set with a Function-Data-Units sequence of program codes.

Data. "Data" in this sense refers only to number values and not to the entire Data message. The term is derived from the bank of front-panel DATA keys. Data can be any number, of arbitrary length, in fixed point notation. Digits beyond the display capability of a particular parameter are truncated. Therefore, it is best to format the data so that it is rounded to the correct number of digits. Leading zeroes are also acceptable, with the exception that a leading zero in the 10 GHz location will cause a digit overflow error (however, in most controllers, fixed point notation suppresses leading zeroes, thus circumventing the error).

Signs preceding data are generally ignored. The exception to this rule is data with the unsigned dBm code (DM). With this program code only, data can be preceded with a plus or minus. Otherwise, the +D or -D codes would be used for +dBm or -dBm.

Single-Value Parameters. Parameters such as "INT 1k" and "LIN 1000", are set with a single program code.

The Knob. Programming a single step of the knob requires that the program code RU or RD be sent ten times. The exceptions to this rule are: In Manual sweep mode, one program code produces one sweep step and when Special function 94 or 95 is enabled; one program code will perform one step (refer to the operating instruction entitled "Knob Increment/Revolution").

Special Functions. Special functions are capabilities that are not explicitly described on the front panel. They are programmed with SP and a numeric code (the single program code SP or the keystroke-like sequence BL AP can be used for SPECIAL). The numeric codes are listed under the operating instruction entitled "Special Functions" or on the Generator's pull-out information card.

Detailed Operating Instructions. The detailed operating instructions in this section of the manual present examples of program code sequences for most of the Generator's functions. An index of detailed instructions is located in Table 3-1.

Upper-Lower Case Letters. Either upper or lower case letters can be used in a Data message. Also the number 0 is interchangeable with the letter O (or o), and the character ?, is interchangeable with @.

Recognizable Characters. The Generator can recognize only the following ASCII characters in a data message:

LF ! + - . 0-9 a-z A-Z @

All other characters, including spaces, are ignored by the Generator. However, if a space or other such char-

acter were inserted between the two characters of a program code, the program code would be invalid and any remaining characters in a string might be misinterpreted by the Generator.

Thus the following entries would be valid ...

FR 1,200,000 HZ;AP -30DM
 FR 1200000HZAP-30DM
 FR 1 200 000 HZ AP -30 DM

... but the following entry would be invalid:

F R1200000HZAP-30DM

Execution Modes. The Generator can accept and process ASCII characters in either the Deferred or Immediate execution modes. Refer to the operating instruction entitled "HP-IB Execution Modes".

3-24 Sending Data Messages

The Generator can send Data messages when in remote and addressed to talk. The four types of information it can send in a Data message are listed below:

1. The Request Service Mask Value (explained in the operating instruction entitled "HP-IB Request Service Mask").

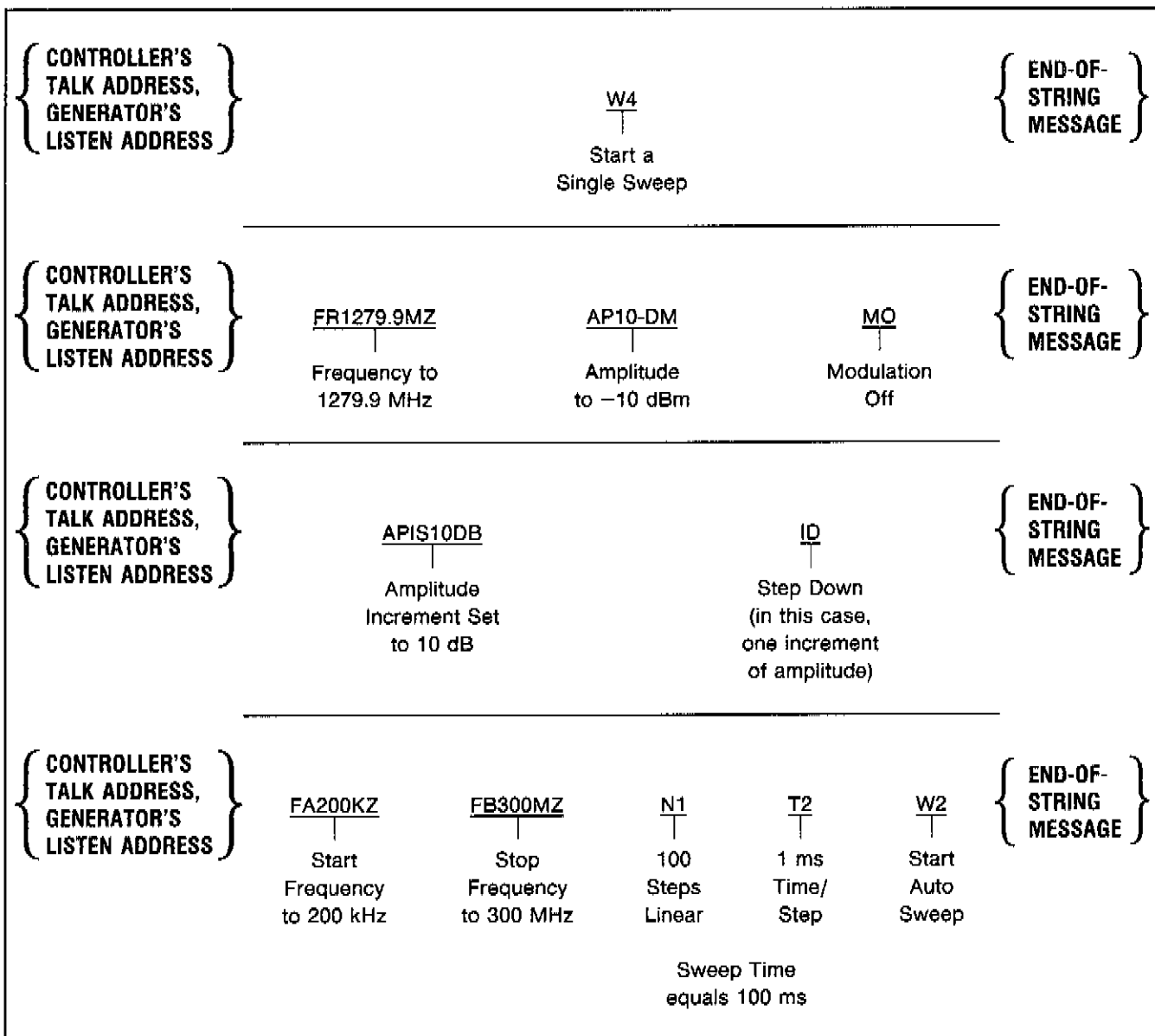

Figure 3-3. Data Message Examples

2. **STATUS Key Message.** (Refer to operating instruction entitled "HP-IB STATUS Key Message".)
3. **Front Panel Learn Data.** (Refer to the operating instruction entitled "Front-Panel Learn Mode").
4. **"Fast" Learn Data.** (Refer to the operating instruction entitled "Fast" Learn Mode).

3-25. Receiving the Trigger Message

The Generator responds to a Trigger message only if a response has been preprogrammed (refer to the operating instruction entitled "HP-IB Trigger Response"). Otherwise, it ignores a Trigger message.

3-26. Receiving the Clear Message

A description of the Generator's response to the Clear message can be found in the operating instruction entitled "System Clear". The Generator responds equally to Selected Device Clear and Device Clear bus commands (SDC and DCL).

3-27. Receiving the Remote Message

The Remote message causes the Generator to switch to remote mode. It has two parts:

1. remote enable and
2. address-to-listen.

The Generator's output does not change with the local-to-remote transition. The REMOTE light turns on only when the Generator is in remote mode and after receiving its first Data Message. The ADDRESSED light turns on when the Generator is addressed to talk or listen.

3-28. Receiving the Local Message

The Generator returns to front panel control when it receives the Local message. Its output does not change with the remote-to-local transition. When the Generator goes to local mode, the front panel REMOTE indicator turns off. However, the ADDRESSED indicator would still illuminate if the Generator were addressed. The local message is the means by which the controller sends the Go to Local (GTL) bus command.

The front-panel Blue Key can also return the Generator to local mode. However, pressing the Blue Key might interrupt a Data message to the Generator. This would leave the Generator in a state unknown to the controller. This situation would be undesirable and could be avoided by sending the Local Lockout message which disables the Blue Key.

3-29. Receiving the Local Lockout Message

After receiving the Local Lockout message, the Generator's Blue Key return-to-local function is disabled. With Local Lockout in effect, the Generator can be returned to local only by the controller. The Local Lockout message is the means by which the controller sends the Local Lockout (LLO) bus command.

3-30. Receiving the Clear Lockout/Set Local Message

The Generator responds to the Clear Lockout/Set Local message in the same way as to the Local message (that is, it returns to front-panel control). The Generator need not be addressed to listen. This message is the means by which the controller sets the Remote Enable (REN) bus line false.

3-31. Receiving the Pass Control Message

The Generator does not respond to the Pass Control message because it cannot act as a controller.

3-32. Sending the Request Service Message

The Generator sends a Request Service message if one of the following conditions exist and if it has been preprogrammed to send the message by the Request Service (RQS) Mask. Refer to the detailed operating instruction entitled "HP-IB Request Service (RQS) Mask".

3-33. Sending the Status Byte Message

The Generator has the capability to send an 8-bit byte which reflects the instrument's current operating condition. Refer to the detailed operating instruction entitled "HP-IB Status Byte".

3-34. Sending the Status Bit Message

The Generator does not respond to a Parallel Poll Enable bus command (PPE) and thus cannot send a Status Bit Message.

3-35. Receiving the Abort Message

The Generator stops talking or listening when it receives the Abort message. The Abort message is the means by which the controller sets the Interface Clear (IFC) bus line true.

Table 3-5. HP-IB Program Codes (Alphabetical Order)*

Code	Parameter	Code	Parameter
AP	Amplitude	RD	Knob, CCW (Down)**
AO	Amplitude Off	RM	Read RQS Mask
AM	AM	RU	Knob, CW (UP)**
AS	Auto Sequence	R1	Resolution X10 (ON)
BL	Blue Key	R2	Resolution 1/10 (ON)
BP	BPSK	R3	Knob Off
BS	Backspace	R4	Knob Hold
CT	Configure Trigger	R5	Knob Increment
DB	dB	SP	Special Function
DG	deg	SQ	Sequence
DM	dBm (w/sign on data)	SS	Set Sequence
DN	Down ↓	ST	Store
FA	START FREQ	TR	Trigger
FB	STOP FREQ	T1	0.5 ms/step (sweep)
FM	FM	T2	1 ms/step (sweep)
FR	FREQUENCY	T3	2 ms/step (sweep)
FS	SPAN FREQ	T4	10 ms/step (sweep)
GZ	GHz	T5	100 ms/step (sweep)
HZ	Hz	UP	Up ↑
IS	Increment Set	UV	μV
KZ	KHz	W1	Sweep Off
L1	Front Panel Learn	W2	Auto Sweep
L2	"Fast" Learn	W3	Manual Sweep
MF	MOD FREQ	W4	Single Sweep
MO	MOD OFF	X1	Marker 1
MS	Read Status Message	X2	Marker 2
MV	mV	X3	Marker 3
MZ	MHz	X4	Marker 4
M1	INT 400	X5	Marker 5
M2	INT 1K	X6	Markers All Off
M3	EXT AC	Y0	Remote Stepped Sweep Off
M4	EXT DC	Y1	RSS with display
N1	100 steps—lin sweep	Y2	RSS without display
N2	1000 steps—lin sweep	Y3	RSS Execute
N3	SET SIZE—lin sweep	@1	Write RQS Mask
N4	Log 10% steps	@2	Deferred Execution Mode
N5	Log 1% steps	@3	Immediate Execution Mode
PC	Percent	0-9	Numerals 0-9
PL	PULSE	.	Decimal Point
PM	Phase Modulation	+D	+dBm
RC	Recall	-D	-dBm

* Program codes can be either in upper case or lower case.

** RD and RU must be sent ten times to execute one step (except when in the Manual Sweep mode or when Special 94 or 95 is enabled, where one program code will perform one step).

Table 3-6. HP-IB Program Codes (Functional Order)*

Parameter	Code	Parameter	Code
Frequency		Sweep (cont'd)	
Frequency	FR	Log 10%	N4
Amplitude		Log 1%	N5
Amplitude	AP	0.5 ms/Step (sweep)	T1
Amplitude Off	AO	1 ms/Step (sweep)	T2
Modulation		2 ms/Step (sweep)	T3
AM	AM	10 ms/Step (sweep)	T4
BPSK	BP	100 ms/Step (sweep)	T5
FM	FM	Marker 1	X1
MOD FREQ	MF	Marker 2	X2
Modulation Off	MO	Marker 3	X3
INT 400	M1	Marker 4	X4
INT 1K	M2	Marker 5	X5
EXT AC	M3	Markers All Off	X6
EXT DC	M4	Remote Stepped Sweep Off	Y0
PULSE	PL	RSS With Display	Y1
PHASE MODULATION	PM	RSS Without Display	Y2
Data		RSS Execute	Y3
Numerals 0-9	0-9	Other	
Decimal Point	.	Blue Key	BL
Back Space	BS	Up (↑)	UP
Units		Down (↓)	DN
dB	DB	Increment Set	IS
deg	DG	Knob CW (Up)**	RU
dBm (w/sign on data)	DM	Knob CCW (Down)**	RD
+dBm	+D	Resolution X10 (ON)	R1
-dBm	-D	Resolution 1/10 (ON)	R2
mV	MV	Knob, Off	R3
μV	UV	Knob, Hold	R4
Percent	PC	Knob increment	R5
Hz	HZ	Knob, Increment	
kHz	KZ	Sequence	SQ
MHz	MZ	Auto Sequence	AS
GHz	GZ	Set Sequence	SS
Sweep		Store	ST
Sweep Off	W1	Recall	RC
Auto Sweep	W2	Configure Trigger	CT
Manual Sweep	W3	Trigger	TR
Single Sweep	W4	Write Require Service Mask	@1
Start Frequency	FA	Read Require Service Mask	RM
Stop Frequency	FB	Read Status Key Message	MS
Frequency Span	FS	Front Panel Learn	L1
100 Steps (linear)	N1	"Fast" Learn	L2
1000 Steps (linear)	N2	Deferred Execution Mode	@2
SET SIZE (linear)	N3	Immediate Execution Mode	@3
		Special Functions	SP

* Program codes can be either in upper case or lower case.

** RD and RU must be sent ten times to execute one step (except when in the Manual Sweep mode or when Special 94 or 95 is enabled, where one program code will perform one step).

ALC BANDWIDTH REDUCTION (Special Function 20 and 21)

Description

This instruction details how to decrease the ALC loop bandwidth, from greater than 100 kHz, to less than 1 kHz. Reduction of the ALC bandwidth significantly improves the ALC's intermodulation distortion characteristics.

Procedure

To reduce ALC bandwidth, select Blue Key, SPECIAL and 21.

To restore normal bandwidth (greater than 100 kHz), select Blue Key, SPECIAL and 20.

Example

Reduce ALC bandwidth.

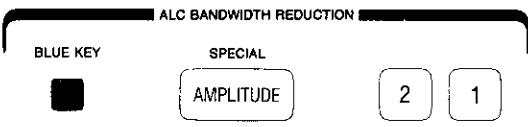
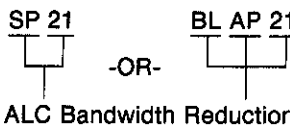
LOCAL (keystrokes)	
HP-IB (program codes)	

Keys and Program Codes

All of the keys and program codes for this feature are shown in the example. Note: SPECIAL can be programmed with SP or with BL and AP (Blue Key and AMPLITUDE).

Indications

There is no apparent indication that this feature has been enabled until the STATUS key is pressed and held. Code 21 will appear in the Special Functions block of the FREQUENCY readout.

Comments

None.

Related Functions

None.

AMPLITUDE

Description

This instruction details how to set the RF output amplitude to a specified level.

OPERATING CHARACTERISTICS

- Output Range (in dBm): +16 to -129.9 dBm.
- Output Range (in volts): 999 mV to 0.072 μ V. (Refer to Comments.)
- Resolution (in dB): 0.1 dB.
- Resolution (in volts): 0.001 μ V to 1 mV. (Refer to Comments.)

Procedure

To set RF output amplitude, select AMPLITUDE, Data and Units.

To turn amplitude off (that is, output less than -150 dBm) select AMPLITUDE then FCTN OFF.

Example

Set RF signal amplitude to -12.7 dBm.

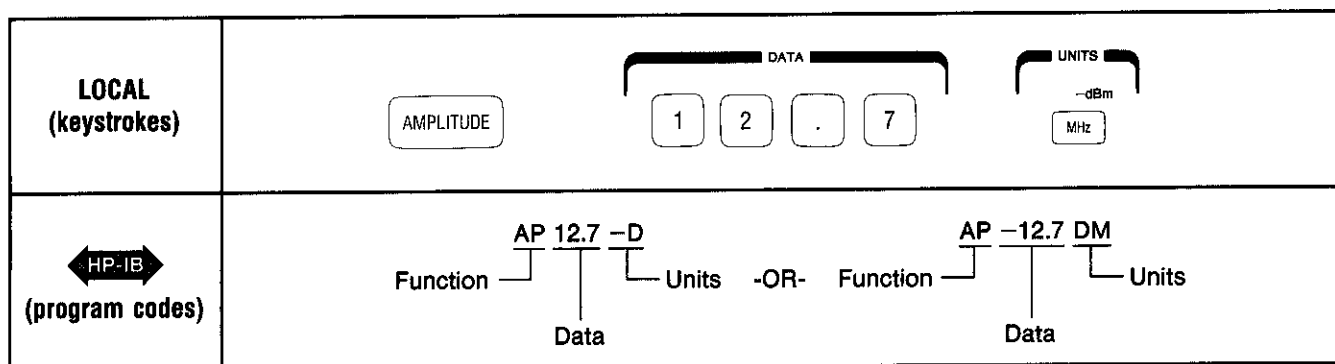

Keys and Program Codes

Keys	Codes
AMPLITUDE	AP
Amplitude Off	AO
+dBm	+D
-dBm	-D
dBm (with sign on data)	DM
mV	MV
μ V	UV

Indications

The selected amplitude (with sign) will be displayed in the appropriate units on the AMPLITUDE readout. The one's digit is always displayed. Otherwise, leading zeros are blanked. When four significant digits are selected between -100.0 and -129.9 dBm, the tenth's digit will not appear until after the -dBm key is pressed.

When the Amplitude is turned off (Amplitude, FCTN OFF), the AMPLITUDE readout will display "----".

Comments

Digits that are selected beyond the instrument's specified resolution are truncated.

The Signal Generator uses microprocessor correction to achieve ± 1 dB absolute output level accuracy from +16 dBm to -120 dBm. The correction feature is automatically enabled upon power-up.

Correction can be defeated with Special Function 85 and restored with Special Function 86.

Correction is also available in the RF frequency sweep mode (Special Function 87).

Amplitude overrange extends to +19.9 dBm. However, this overrange cannot be selected in voltage units; 999 mV (the equivalent of +13 dBm) is maximum.

When the Amplitude is expressed in units of volts, the resolution is dependent upon the actual level. This is because the Generator (in the Amplitude increment mode), changes in 0.1 dB increments only.

When AMPLITUDE, FCTN OFF is selected, the instrument's internal modulators reduce the signal level (prior to the Output Attenuator) to less than -15 dBm. The Output Attenuator is set for maximum attenuation (-135 dB), thus reducing the output amplitude to a net value of -150 dBm or less.

◀ HP-IB ▶

Data can be entered with leading sign under HP-IB control only (for example, +13 DM). Otherwise, the sign must be incorporated in the units (that is, +D or -D).

Related Functions

Amplitude Conversion (V \leftrightarrow dBm)
Amplitude Correction
Amplitude Correction, Sweep Mode
Amplitude, Manual Level-Control
Amplitude, Microvolt Reference
Amplitude Reference

AMPLITUDE CONVERSION, (V → dBm) (Special Function 81)

Description

This instruction details how to convert the display of RF amplitude, expressed in units of volts, to units of power in dBm. This feature does not effect the actual output level.

Procedure

To convert RF amplitude, expressed in units of volts to units of power, select Blue Key, SPECIAL and 81.

Example

Convert the amplitude units (as displayed in mV or μV) to dBm.

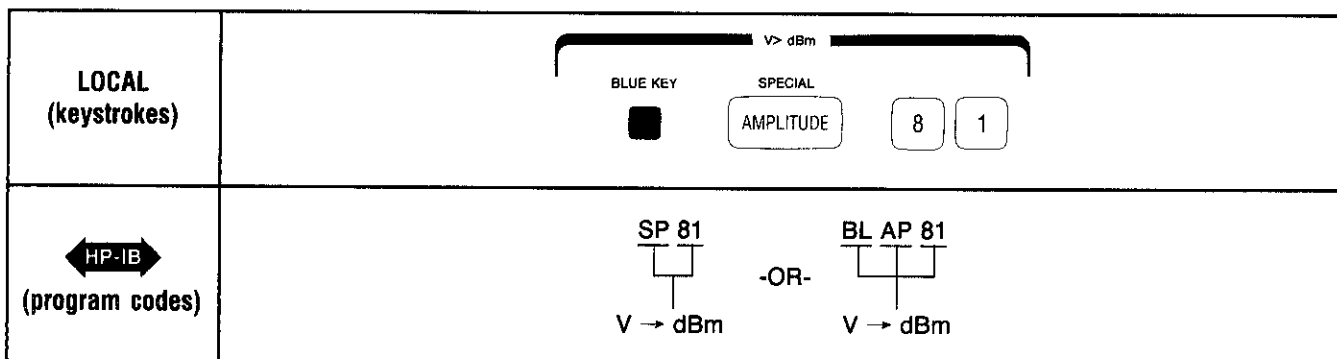

Keys and Program Codes

All of the keys and codes for this feature are shown in the example. Note: SPECIAL can be programmed with a simple SP or with BL and AP (Blue Key and Amplitude).

Indications

After the Amplitude readout changes to a value in dBm, there is no other indication that the conversion was made.

Comments

There is no built-in conversion feature for dBm-to-volts. However, the following formula can be used to determine voltage when the output level is expressed in units of power:

$$V = (0.05)^{1/2} * (10)^{P/20}$$

where V is the level in volts (rms) and P is the level of power in dBm.

Related Functions

- Amplitude
- Amplitude Correction
- Amplitude Reference
- Amplitude, Manual Level-Control
- Amplitude, Microvolt Reference

AMPLITUDE CORRECTION (Special Function 85 and 86)

Description

This instruction details how to disable and enable the RF Amplitude Correction function.

The Amplitude Correction feature, which is automatically enabled at turn-on, corrects for internal amplitude variations that are inherent throughout the Generator's frequency range.

Correction can be disabled by Special Function 85 and re-enabled by Special Function 86.

Operating Characteristics

- Absolute Level Accuracy (+15° to +45° C):
- ±1 dB, (-120 dBm < RF level ≤ +16 dBm).
- ±3 dB, (-130 dBm < RF level ≤ -120 dBm).

NOTE

The Amplitude Correction feature is available for the output range of +16 to +19.9 dBm. If enabled, the Correction feature will cause the RF output level to increase to a more accurate value. The RF level, however, may not comply with the Absolute Level Accuracy specifications.

- Flatness (without Correction, down to -120 dBm):
- ±1.5 dB, (Frequency range; 0.1-1280 MHz).
- ±3.5 dB, (Frequency range; 0.1-2560 MHz).

Procedure

To disable the correction feature, select Blue Key, SPECIAL and 85.

To re-enable the correction feature, select Blue Key, SPECIAL and 86.

Example

Disable the Amplitude Correction feature.

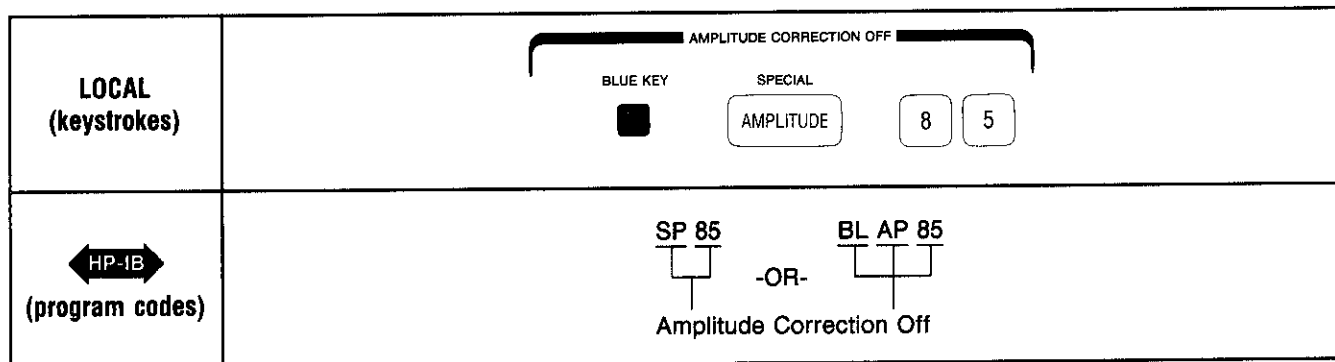

Keys and Program Codes

All of the keys and program codes for this feature are shown in the example.

Indications

If the Correction feature is defeated, the value displayed on the AMPLITUDE readout will not change. However, the actual RF amplitude might change to a less accurate value.

There is no indication that the correction feature has been disabled until the STATUS key is pressed and held. Code 85 will then appear in the Special Functions block of the FREQUENCY readout.

Comments

If maximum level accuracy is not required during long periods of rapid frequency-changing (Auto Sequence or HP-IB controlled frequency changing), the Amplitude Correction feature should be disabled. This will eliminate excessive mechanical wear of the Output Attenuator.

Related Functions

Amplitude
Amplitude Conversion (V → dBm)
Amplitude Reference
Amplitude Correction, Sweep Mode
Amplitude, Manual Level-Control

AMPLITUDE CORRECTION, SWEEP MODE (Special Function 87)

Description

This operating instruction details how to enable the Amplitude Correction function, RF frequency sweep modes inclusive.

Correction is available in all four sweep modes (Manual, Auto, Single, and Remote Stepped Sweep). Refer to the operating instruction entitled "Sweep" for sweep-related information.

Absolute Level Accuracy (+15° to +45° C):
 ±1 dB (Output level between +16 and -120 dBm).
 ±3 dB (Output level between -120 and -130 dBm).

NOTE

The Amplitude Correction feature is available from +16 to +20.0 dBm and will cause the RF output level to increase to a more accurate value. These values, however, may not comply with the Absolute Level Accuracy specifications.

Procedure

To enable the Amplitude Correction, Sweep Mode feature, select Blue Key, Special and 87.

To turn Amplitude Correction off (during sweep mode only), select Blue Key, Special and 86.

To turn Amplitude Correction off in all modes, select Blue Key, Special and 85.

Example

Enable the Amplitude Correction, Sweep Mode feature.

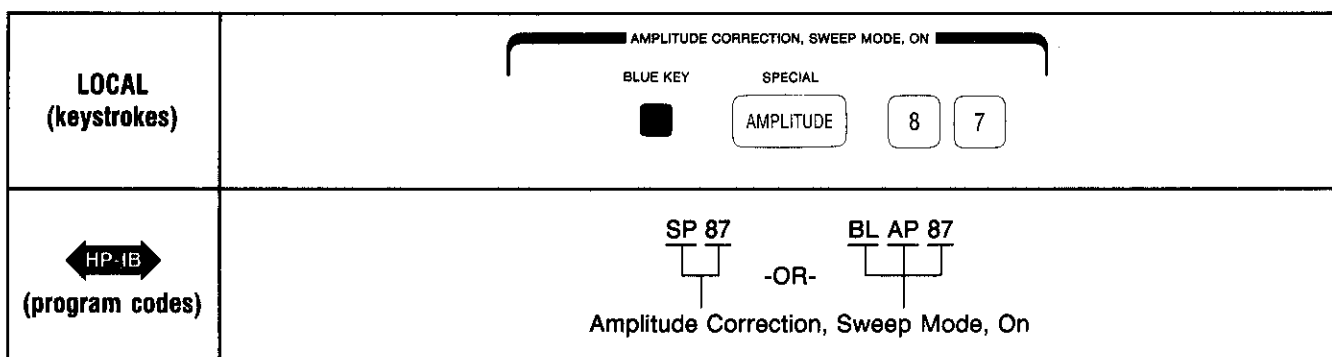

Keys and Program Codes

All of the keys and program codes for this feature are shown in the example. Note: SPECIAL can be programmed with a simple SP or with BL and AP (Blue Key and AMPLITUDE).

Indications

There is no apparent indication that this feature has been enabled until the STATUS key is pressed and held. Code 87 will appear in the Special Functions block of the FREQUENCY readout.

The RF output level, displayed on the AMPLITUDE readout, will not change when the Amplitude Correction function is enabled. The Generator, however, will achieve its optimum, output level-accuracy (sweep mode inclusive).

Comments

When Special Function 87 is enabled, the Generator does not use the mechanical Output Attenuator to compensate for level inaccuracies during an RF Sweep.

The only mechanism used for output leveling during an FF sweep is the instrument's electronic RF Vernier.

NOTE

The RF Vernier consists of the instrument's modulators, ALC circuit and Output Amplifier.

Since the modulators are used to correct for level inaccuracies when Special Function 87 is enabled, AM performance can be degraded when the instrument is operated with simultaneous high AM depths and high carrier rates.

When the amplitude correction function is active during an RF sweep, the minimum accurate sweep time is 10 ms (refer to operating instruction entitled "RF Sweep, Time/Step").

Related Functions

Amplitude

Amplitude Conversion, (V → dBm)

Amplitude Reference

Amplitude Correction

Amplitude, Manual Level-Control

AMPLITUDE REFERENCE (Special Function 30 and 31)

Description

This instruction details how to convert the display of RF amplitude (in dBm) to a reference value of 0.0 dB. This feature, by itself, does not change the actual RF level.

After the Amplitude Reference function is enabled, any change in amplitude will be displayed in units of dB relative to the selected reference.

Procedure

To change the displayed amplitude from absolute units of dBm, to a reference of 0.0 dB, select Blue Key, SPECIAL and 31.

To turn off the Amplitude Reference feature, select Blue Key, SPECIAL and 30.

Example

Change the display, which reads -107 dBm, to indicate a reference level of 0.0 dB.

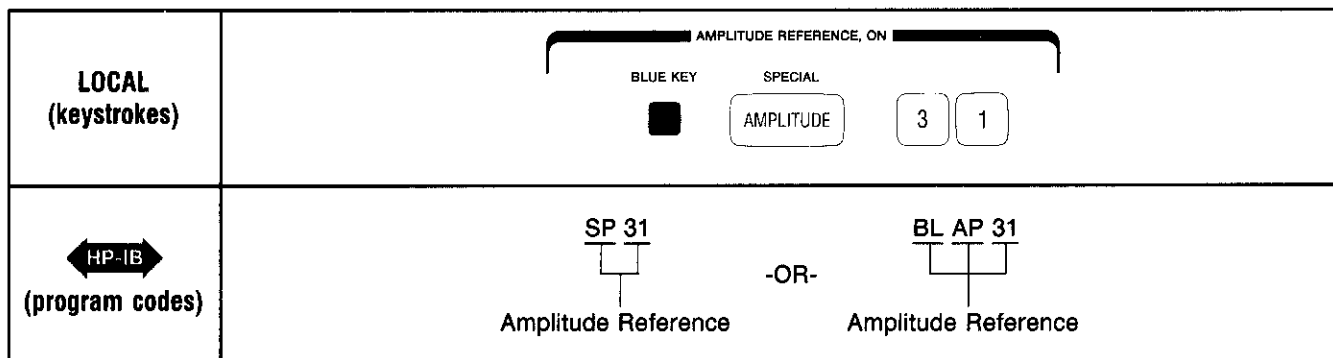

Keys and Program Codes

All of the keys and codes used in the Amplitude Reference feature are shown in the examples. Note: the SPECIAL function can be programmed with a simple SP or BL and AP (Blue Key and AMPLITUDE).

Indications

The Amplitude readout will display 0.0 dB when the Amplitude Reference function is enabled. There will, however, be no change in actual output level at this point. Any subsequent change in output level will be displayed in units of dB relative to the selected reference.

Code 31 will appear in the Special Function block of the Frequency readout if the STATUS key is pressed and held.

Comments

Before the Amplitude Reference feature can be invoked, the Amplitude must be expressed in units of dBm. If the units are mV or μ V, they must be converted to dBm (refer to the Amplitude Conversion operating instruction, Special 81).

If the Amplitude Reference function is defeated (Special Function 30), the amplitude (expressed in dB) will be converted to its absolute level in units of dBm.

In the Amplitude Reference mode, output level can be varied with the INCREMENT UP or DN keys or the Knob. A completely new setting; that is, a Function, Data, Units entry will turn off the reference feature.

Related Functions

Amplitude
Amplitude Conversion (V → dBm)
Amplitude Correction
Amplitude Correction, Sweep Mode
Amplitude, Manual Level-Control
Amplitude, Microvolt Reference

AMPLITUDE, MANUAL LEVEL-CONTROL (Special Function 93)

Description

This instruction details how to manually define RF Vernier levels and Output Attenuator settings.

NOTE

The RF Vernier consists of the instrument's modulators, ALC circuit, and Output Amplifier.

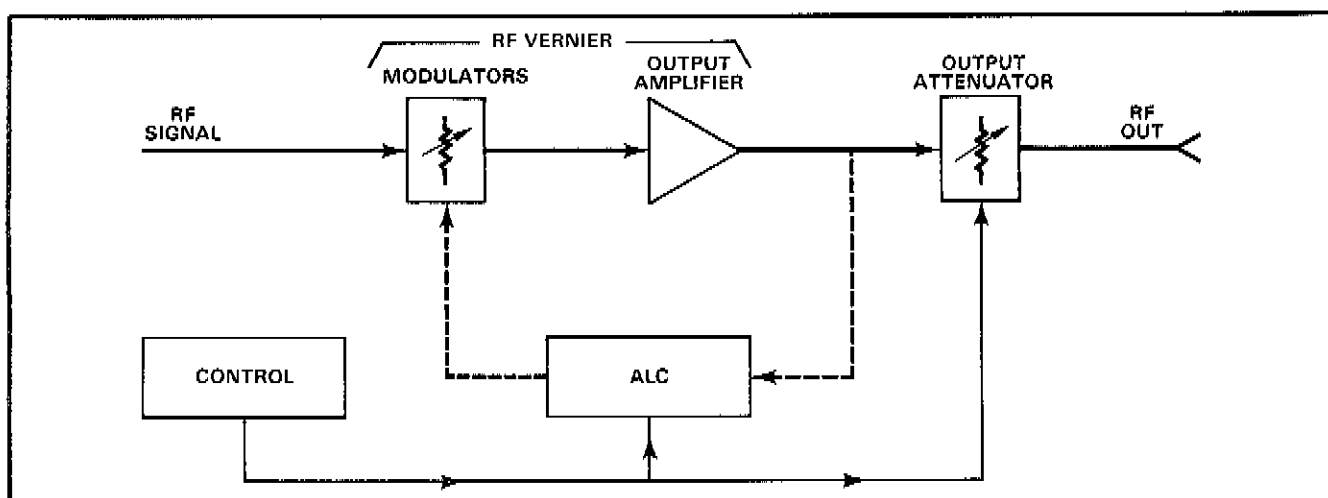

In the normal operating mode, the Generator uses a level-control algorithm to determine (from the entered amplitude) the optimum setting for the RF Vernier and Output Attenuator.

Enabling Special Function 93, however, defeats the automatic level-control algorithm and allows the user to independently define both RF Vernier and Output Attenuator settings.

Operating Characteristics:

RF Vernier Output Range: +0.1 to +19.9 dBm (0.1 dB increments).

Output Attenuator Range: 0 to -135 dB (5 dB increments).

Flatness (without Correction, down to -120 dBm):

±1.5 dB, (Frequency range; 0.1-1280 MHz).

±3.5 dB, (Frequency range; 0.1-2560 MHz).

Procedure

RF level settings must only be entered with numeric keystrokes (Knob and Increment functions are disabled).

To turn the Manual Level-Control function on, select Blue Key, SPECIAL and 93.

To set RF Vernier level, select Data and Units (“+dBm” is the only valid Units entry).

To set the Output Attenuator level, select Data and Units (“-dBm” is the only valid Units entry).

Example

Turn on the Manual Level-Control feature.

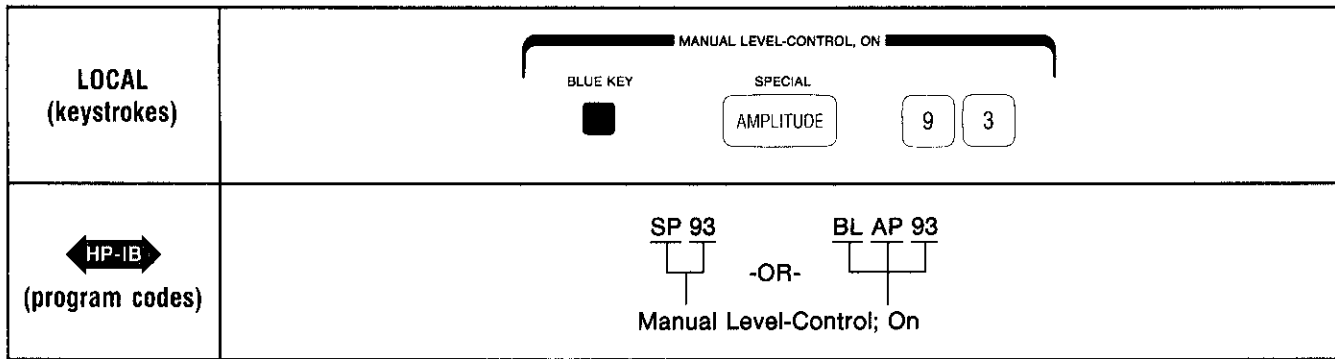

Set RF Vernier output level to +10.0 dBm.

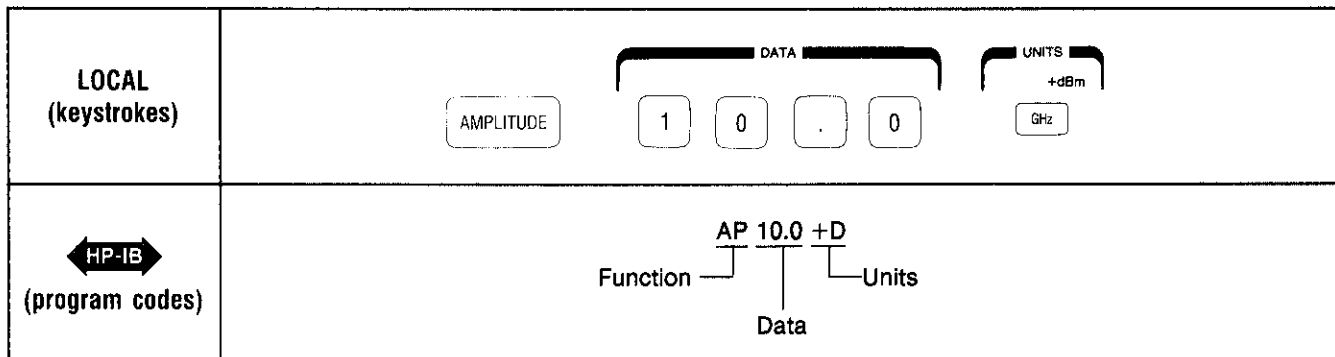

Set Output Attenuator level to -120 dB.

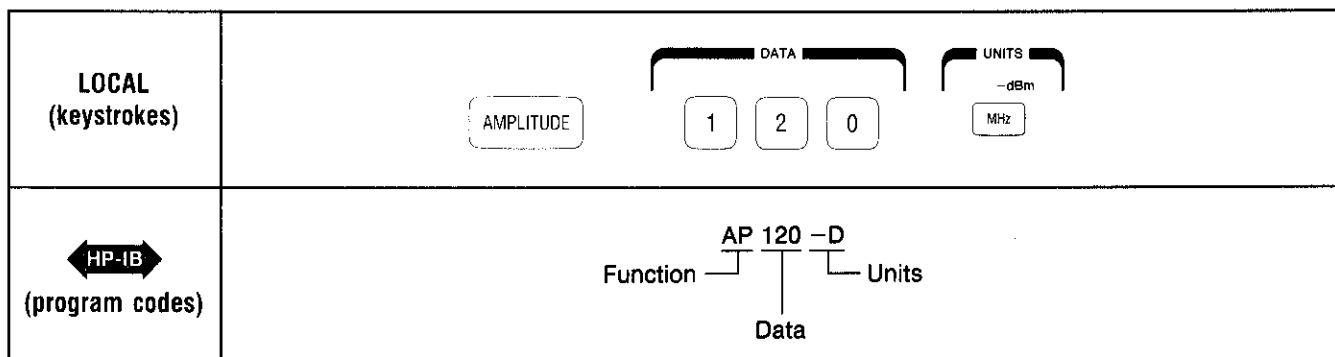

Keys and Program Codes ↔ HP-IB ↔

Keys	Codes
Blue Key	BL
SPECIAL	SP
+dBm	+D
-dBm	-D

Indications

The AMPLITUDE readout will display the sum of the Vernier level and Output Attenuator setting (in units of dBm).

There is no apparent indication that the Manual Level-Control function has been enabled until the STATUS key is pressed and held. Code 93 will appear in the Special Functions block of the FREQUENCY display.

Comments

To turn the Manual Level-Control function off, enter Special Function 86 which re-enables the Amplitude Correction function.

Related Functions

Amplitude
Amplitude Correction

AMPLITUDE, MICROVOLT REFERENCE (Special Function 30 and 32)

Description

This instruction details how to convert the Generator's RF amplitude to a relative value, referenced to a one microvolt (rms) level. (Equivalent to -107 dBm.)

When the Microvolt Reference function is enabled, the Amplitude readout will display 0.0 dB; the actual output level however, is -107 dBm. Any subsequent change in RF amplitude will be displayed in units of dB, relative to the one microvolt level.

Operating Characteristics

Output Amplitude Range: -22.9 dB μ V to $+123.0$ dB μ V. (One microvolt reference)
Resolution: 0.1 dB.

Procedure

To enable the Microvolt Reference function, select Blue Key, SPECIAL, then 32.
Enter the desired amplitude. (Amplitude entry must be in units of +dB or -dB).

Note

Units keys, +dBm and -dBm, are redefined as +dB μ V and -dB μ V respectively.

To turn the Microvolt Reference function off, select Blue Key, SPECIAL, and 30.

Example

Enable the Microvolt Reference function.

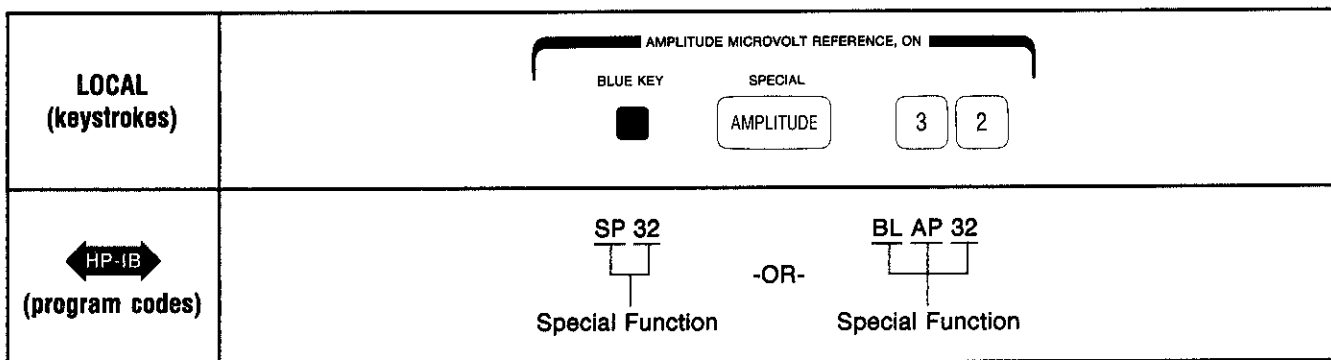

Set RF signal amplitude to 77 dB above a microvolt.

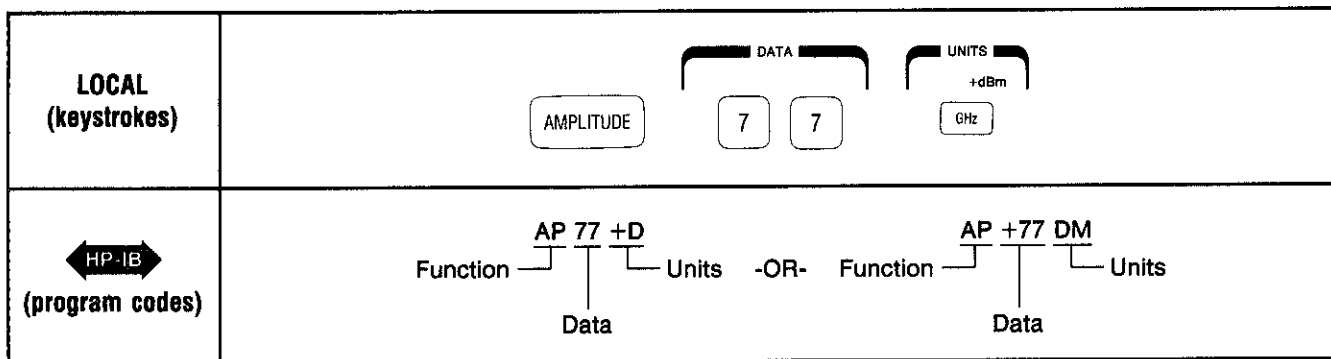

Keys and Program Codes 

Keys	Codes
SPECIAL	SP
AMPLITUDE	AP
Amplitude	AO
Off	
+dBm	+D
-dBm	-D

Indications

The AMPLITUDE readout will read 0.0 when the Microvolt Reference function is enabled. The AMPLITUDE units annunciators dB and μ V will also be lit.

Code 32 will appear in the Special Functions block of the FREQUENCY display if the STATUS key is pressed and held.

The selected amplitude (with sign and units) will be displayed on the AMPLITUDE readout. The one's digit is always displayed. Otherwise, leading zeros are blanked. When four significant digits are selected between +100.0 and +123.0 dBuV, the tenth's digit will not appear until after the units key is pressed.

Comments

Digits selected beyond the specified resolution are truncated.

When the Microvolt Reference function is defeated (Special Function 30), the amplitude (expressed in dB μ V) is converted to its absolute level in units of dBm.

Related Functions

Amplitude
 Amplitude Conversion, (\rightarrow dBm)
 Amplitude Reference

FREQUENCY

Description

This instruction details how to set the frequency of the Generator's RF output.

Operating Characteristics:

Range: 100 kHz-2560 MHz (2559.999 999 6)

Resolution: 0.1 Hz (below 640 MHz)

0.2 Hz (640 MHz ≤ carrier < 1280 MHz)

0.4 Hz (carrier ≥ 1280 MHz)

Procedure

To enter an RF frequency, select FREQUENCY, Data and Units.

Example

Set RF output frequency to 250 MHz.

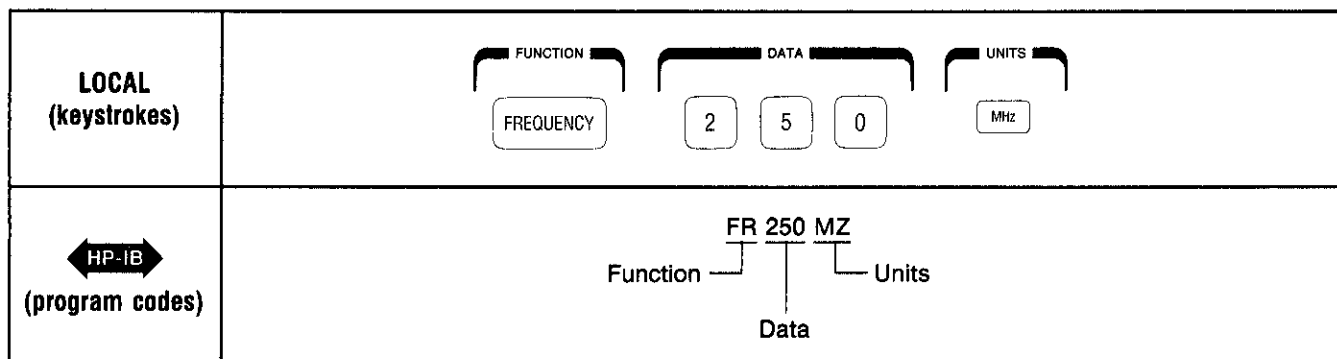

Keys and Program Codes

Keys	Codes
FREQUENCY	FR
GHz	GZ
MHz	MZ
kHz	KZ
Hz	HZ

Indications

Entering the RF output frequency will cause the FREQ function indicator to turn on. The frequency and units entered will appear on the FREQUENCY readout; leading zeros will be blanked. Less significant digits display zeros if not selected (except for the tenth-hertz digit which should be blanked).

Comments

Digits selected beyond the specified resolution are truncated.

RF frequencies as low as 1 kHz can be selected, however, the Generator's signal characteristics are not specified below 100 kHz.

Related Functions

Frequency Hopping
Frequency Offset
Frequency Copying
RF Sweep

FREQUENCY COPYING

Description

This instruction details how to copy a frequency value from one of the instrument's frequency-related parameters into another.

The frequency value contained in the originating parameter will remain unchanged.

Frequency Copying can be performed between two or more of the following parameters:

Frequency	Marker Frequencies
Start Frequency	Sweep Step Size
Stop Frequency	Span Step Size
Span Frequency	

Procedure

To perform the copy function, select Blue Key, then a source parameter followed by the selection of the desired recipient parameter.

Example

Copy the frequency value of Marker 1 into the Start Frequency parameter and the frequency value of Marker 2 into the Stop Frequency parameter.

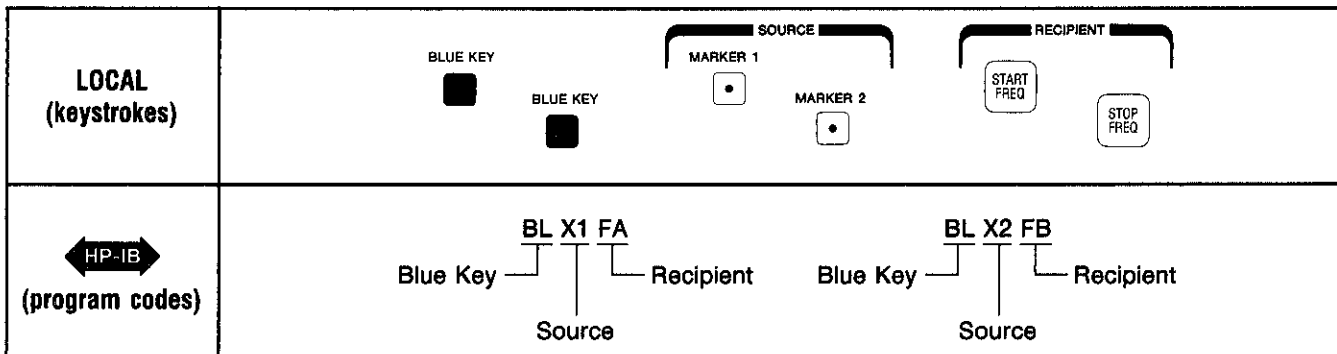

Keys and Program Codes

Keys	Codes
Blue Key	BL
FREQUENCY	FR
START FREQ	FA
STOP FREQ	FB
SPAN FREQ	FS
SET SIZE	N3

Keys	Codes
MARKERS	
1	X1
2	X2
3	X3
4	X4
5	X5
MARKER OFF	X6
ALL OFF	X7

Indications

Indications depend upon the parameter currently being displayed. The source remains unchanged; the recipient will change to the same value as the source.

Comments

None.

Related Functions

Frequency
RF Sweep, Start-Stop
RF Sweep, Span
RF Sweep Markers
Store-Recall

FREQUENCY HOPPING (Special Function 91)

Description

This instruction details how to enable the Generator's Frequency Hopping mode. The instrument has the capability to rapidly switch between six, predetermined RF frequencies.

RF frequency values are stored in the instrument's storage registers (Registers 1-6) and can be selected in any consecutive order.

Register selection is executed by applying a trigger pulse to the appropriate pin on the rear-panel AUX connector; Pins 2-7 correspond with Register 1-6, respectively. Refer to paragraph 3-12 for information regarding the Mode 2 operation of the AUX connector.

Operating Characteristics

Frequency Switching Time: Nominally 550 μ s. (Frequency within 100 Hz of setting)

Trigger pulse: TTL, negative-true (5 μ s minimum).

Available Registers: Register 1-6.

Procedure

To enable the Frequency Hopping mode, select Blue Key, SPECIAL and 91.

To turn the Frequency Hopping function off, select any key except STATUS.

NOTE

Modulation of the RF signal is not available in the Frequency Hopping mode.

To store RF frequencies in Registers 2-6, refer to the Store-Recall operating instruction.

To store a frequency value in Register 1, select FREQUENCY, Data and Units, prior to enabling the Frequency Hopping function. When Special 91 is invoked, the value displayed on the FREQUENCY readout is stored in Register 1.

Example

Enable the Frequency Hopping mode.

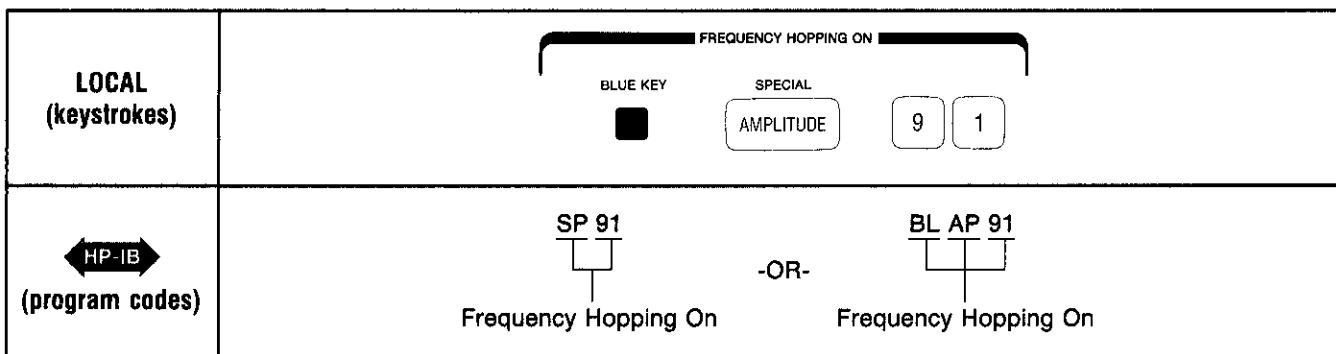

Keys and Program Codes

All of the keys and codes for this feature are shown in the example. Note: SPECIAL can be programmed with a simple SP or with BL and AP (Blue Key and Amplitude).

Indications

When Special 91 is entered, the FREQUENCY readout will blank and a "1" will be displayed in the second digit from the left.

The digit displayed on the readout signifies which register has been selected.

When the STATUS key is pressed and held, Special code 91 will appear in the Special Functions block of the FREQUENCY display.

Modulation annunciators will be turned off.

Comments

When the Frequency Hopping mode is enabled, the Generator recalls and outputs the frequency stored in Register 1. The contents, stored in Register 1, always serve as the instrument's initialized condition when Special 91 is enabled.

The Generator can switch to another register before lock and settling have occurred, however, a minimum setup time of 160 μ s is required between trigger pulses.

The following graph illustrates the Generator's processing and switching time that is needed after the trigger pulse.

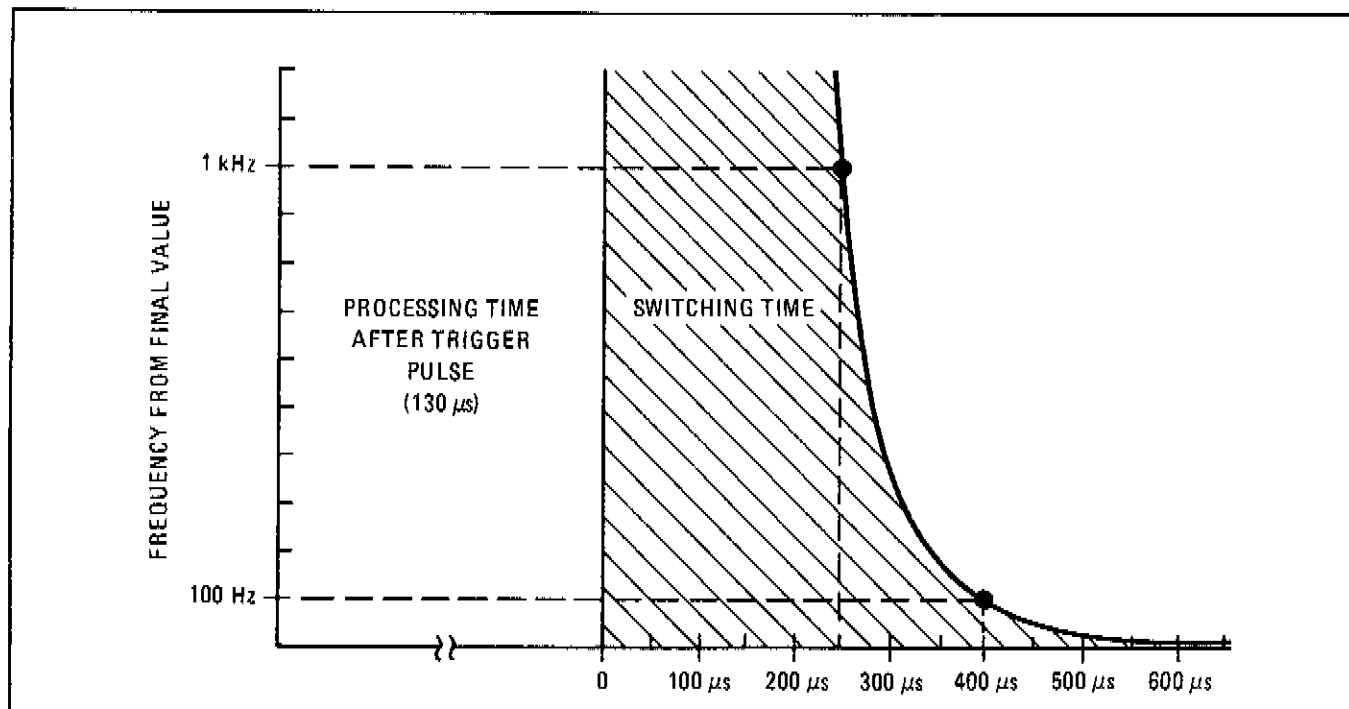

Typical Frequency Switching Time Showing Worst Case Lock and Settling Times

Related Functions

Store-Recall
Sequence

FREQUENCY OFFSET Special Functions 10, 11 and 12)

Description

This instruction details how to select an output frequency with a positive or negative offset from the displayed frequency. Both the amount and direction of offset are selectable.

Procedure

To enter a positive offset, select Blue Key, SPECIAL and 11. When the FREQUENCY readout blanks, enter the frequency offset by selecting Data and Units.

To enter a negative offset, perform the above procedure substituting Special 12 for Special 11.

To remove the offset, select Blue Key, SPECIAL and 10.

Example

Select a positive offset such that the output frequency is 10.7 MHz higher than the displayed frequency.

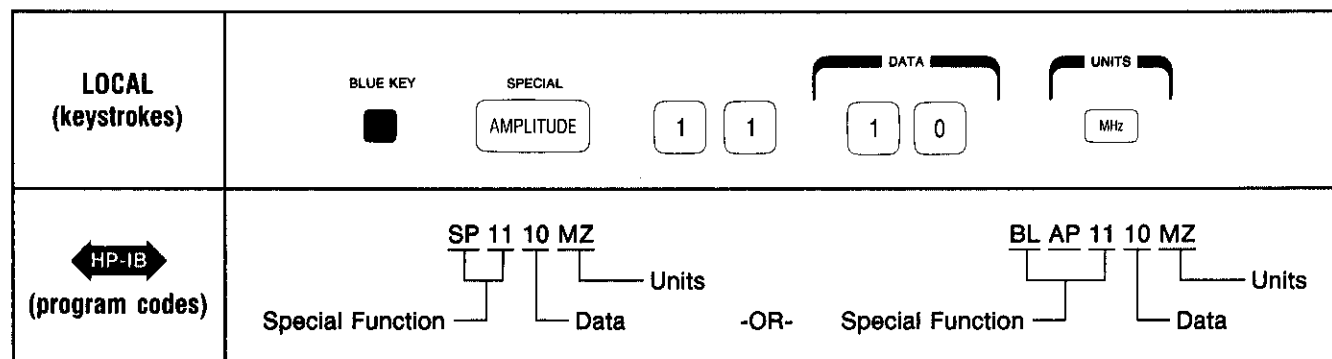

Keys and Program Codes

Keys	Codes
Blue Key	BL
SPECIAL	SP
GHz	GZ
MHz	MZ
kHz	KZ
Hz	HZ

Indications

There is no indication that the Frequency Offset function has been enabled until the STATUS key is pressed and held. The output frequency however, will change by the selected offset.

Code 11 or 12 will appear in the Special Functions block of the FREQUENCY readout when the STATUS key is pressed and held.

The numerical value displayed on the FREQUENCY readout will not change.

Comments

The offset applies to both fixed and swept output frequencies. It also applies to Sweep Start-Stop and Marker frequencies. However, it does not apply to Sweep Span or Step Size.

Related Functions

Frequency
RF Sweep, Start-Stop
RF Sweep, Markers



HP-IB ADDRESS DISPLAY (Special Function 82)

Description

This instruction details how to read the Generator's HP-IB address. The instrument's HP-IB address can be displayed on the FREQUENCY readout.

The HP-IB address display will not time out, but it can be cleared by pressing any key. Selecting a number key however, will cause the selected digit to be displayed on the readout of the last enabled, front panel function.

Procedure

To display the HP-IB address, select the Blue Key, SPECIAL and 82.

Example

Display the Generator's internally-set, decimal address.

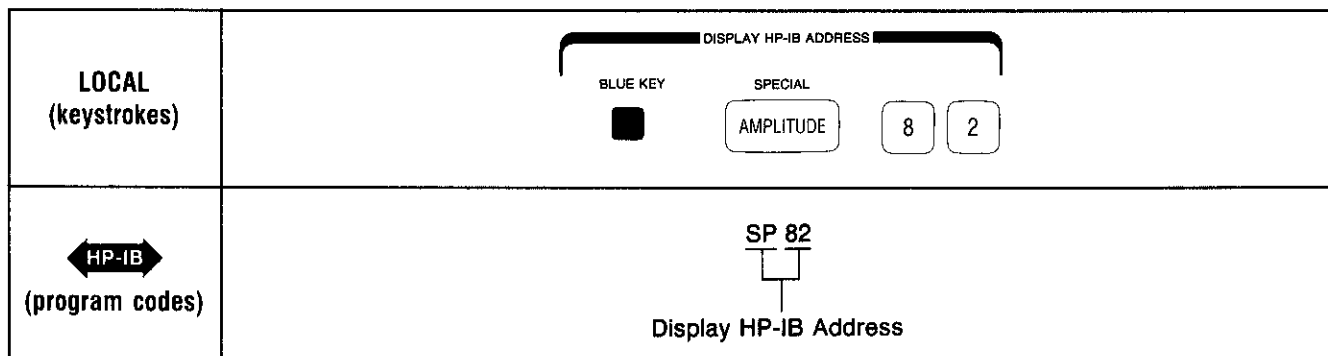

Keys and Program Codes

Keys	Codes
HP-IB Address	None

Indications

The address will be displayed in the format, --XX-- and is the decimal equivalent of the last five bits of both Talk and Listen ASCII address codes.

Comments

HP-IB addresses greater than 30 (decimal) are invalid. The Generator's HP-IB address is factory-set to 19 (decimal) and can only be updated prior to an instrument power-up or reset. To change the address, refer to Section II under "HP-IB Address Selection".

Related Functions

None.



HP-IB EXECUTION MODES (Program Codes @2 and @3)

Description

This instruction details how to select the Generator's mode of processing ASCII characters. The Generator can accept and process ASCII characters in the Immediate or Deferred execution modes.

In the Immediate execution mode (power-up default condition), the Generator produces an internal End-of-String (EOS) message at the end of each character received from the controller. The Generator processes each character before accepting the next one.

In the Deferred execution mode, the Generator accepts strings of up to 82 characters at a time, executing the string upon receiving an EOS message. An EOS message may be a Line Feed (LF), an exclamation mark (!) or a bus END message (that is, bus lines EOI true and ATN false). The Generator produces its own EOS Message upon receipt of the 82nd character in a string.

Procedure

To configure the Generator in the Immediate Execution Mode, send the program code @3 to the instrument.

To configure the Generator in the Deferred Execution Mode, send the program code @2 to the instrument.

Example

Configure the Generator in the Immediate Execution Mode.

Controller	Program Statements
HP-85 (BASIC)	OUTPUT 719; "@3"
HP 9825 (HPL)	wrt 719, "@3"

Comments

The Immediate Execution Mode slows down the overall data transfer rate, however, the Generator can switch faster after the final EOS, than when in the Deferred mode. This can be useful when the system controller's execution time (data rate < 1000 bytes/second) is such that it cannot take advantage of the Deferred mode's transfer speed.

Also, the Immediate mode can be advantageous if switching time (after the final EOS), independent of message length, is more important than program execution speed.

In the Deferred Execution Mode, if a block of strings containing more than 82 characters is sent, the first 82 characters are accepted and the Generator holds the bus busy (NDAC false) until it executes them. Then the next 82 characters are accepted and so on, until the entire block is accepted. If only one string of less than 82 characters is sent (without an EOS), the Generator accepts (but does not process) the string, then frees the bus allowing program execution to continue.



HP-IB "FAST" LEARN MODE (Program Code L2)

Description

The Generator has the capability to send front-panel modulation and frequency configurations to the controller for storage in its memory. These configurations can be recalled at a later time and transferred back to the Generator.

The "Fast" Learn mode significantly decreases the overall execution time of a learn operation in comparison to the Front-Panel Learn Mode, since only modulation and frequency data are transferred.

Procedure

To execute the "Fast" Learn operation, the controller must first send the L2 program code. The Generator is then able to send the current front-panel configuration data to the controller. (The data string consists of 16 8-bit bytes.)

To return the data to the Generator, the controller needs only to send the data string, representative of the front-panel configuration, to the instrument; no separate program code is needed. (The first byte received from the Generator is the first byte returned.)

NOTE

The first two bytes of the information string returned to the Generator instruct the instrument to interpret the subsequent data as "Fast" Learn information.

To exit the "Fast" Learn mode, a "dummy" byte must be sent to the controller. The "dummy" byte can be any eight bit word except 01000000 or 11000000 (ASCII @ or '). When received at the end of a data string, the "dummy" byte instructs the Generator that the "Fast" Learn Mode has ended.

Example

Enable the "Fast" Learn mode and transfer the Generator configuration to the controller's memory.

Controller	Program Statements
HP-85 (BASIC)	OUTPUT 719; "L2" ENTER 719 USING "#,16A"; [string variable]
HP 9825 (HPL)	fmt 1, c16, z wrt 719, "L2" red 719.1, [string variable]

Example

Return the front-panel configuration to the Generator.

Controller	Program Statements
HP-85 (BASIC)	OUTPUT 719 USING "K,16A"; [string variable]
HP 9825 (HPL)	fmt 1, c16, z wrt 719.1, [string variable]

Indications

The FREQUENCY and MODULATION readouts will display all dashes. The AMPLITUDE display will remain unchanged.

Comments

When the "Fast" learn mode is first entered, data representing the front-panel configuration is transferred to the Generator's Register 1. When the Generator receives the "dummy" byte (instead of another sixteen-byte string) it will exit the "Fast" Learn mode and recall the front-panel setup stored in Register 1.

RF amplitude level correction will be disabled. RF and modulation sweep will be turned off and disabled.

All keys are locked-out including the STATUS key, Blue Key and "hidden" parameter-display keys.

The Request Service function is disabled.

When the Generator outputs the data string to the controller, the 16th byte is sent with the bus EOI line true, thus terminating the message.

Whenever data is being transferred between controller and Generator, it must do so in uninterrupted strings. If a data string is broken or interrupted, the data could be lost or offset, and misinterpreted by the Generator. An offset of data bytes will continue to affect subsequent data strings until the Generator is switched to Standby, then ON again.

All Generator functions which cause the front-panel parameters to change (Auto Sequence, RF Sweep, Modulation Sweep etc.) should not be active when a learn operation is being performed (due to the unpredictability of the front-panel data).

The size of the string variable assigned to the "Fast" Learn data must be set to a minimum dimension of 16 elements.

The overall execution time of the "Fast" Learn operation can be significantly decreased by the use of the controller's I/O buffers. I/O data buffers, though limited in flexibility, have rapid data transfer capabilities. Refer to the appropriate controller's I/O programming guide for related information.

Related Functions

HP-IB Front-Panel Learn Mode



HP-IB FRONT-PANEL LEARN MODE (Program Code L1)

Description

The Generator has the capability to send full, front-panel configurations to the controller for storage in its memory. These configurations can be recalled at a later time and transferred back to the Generator.

The Front-Panel Learn mode transfers the Generator's complete front-panel configuration to and from the controller's memory. This information string contains only those parameters that can be stored in the Generator's internal storage registers. (Refer to Store/Recall operating instruction for storage limitations.)

Procedure

To initiate the Front-Panel Learn mode, the Generator must first receive the L1 program code. The Generator is then able to send the current front-panel configuration data to the controller. (The data string consists of 189 8-bit bytes).

To return the data to the Generator, the controller simply needs to output the data string to the instrument; no separate program code is needed. (The first byte received from the Generator is the first byte returned.)

NOTE

The first two bytes of information in the data string designate the following 187 bytes of data as front-panel learn information.

Example

Enable the Front-Panel Learn mode and transfer the Generator configuration to the controller's memory.

Controller	Program Statements
HP-85 (BASIC)	OUTPUT 719; "L1" ENTER 719 USING "#,189A"; [string variable]
HP 9825 (HPL)	fmt 1, c189, z wrt 179, "L1" red 719.1, [string variable]

Example

Return the front-panel configuration to the Generator.

Controller	Program Statements
HP-85 (BASIC)	OUTPUT 719 USING "#,189A"; [string variable]
HP 9825 (HPL)	fmt 1, c189, z wrt 719.1, [string variable]

Comments

When the Generator outputs the data string to the controller, the 189th byte is sent with the bus EOI line true, thus terminating the message.

In the learn mode, when the data representing the front-panel configuration is transferred to the controller, the identical configuration is also stored in the Generator's Register 1.



Whenever data is being transferred between controller and Generator, it must do so in uninterrupted strings. If a data string is broken or interrupted, the data could be lost or offset, and misinterpreted by the Generator. An offset of data bytes will continue to affect concurrent data strings until the Generator is switched to Standby, then ON again.

The overall execution time of the Front-Panel Learn operation can be significantly decreased by the use of the controller's I/O buffers. I/O data buffers, though limited in flexibility, have rapid data transfer capabilities. Refer to the appropriate controller's I/O programming guide for related information.

All Generator functions which cause the front-panel parameters to change (Auto Sequence, RF Sweep, Modulation Sweep etc.) should not be active when a learn operation is being performed (due to the unpredictability of the front-panel data).

The size of the string variable assigned to the Front-Panel Learn data must be set to a minimum dimension of 189 elements.

NOTE

The Status Byte's Operator-Requests-Response condition can be a useful aid in performing learn functions. After the Generator's front panel has been set in the desired configuration (in the local mode) selecting the Blue Key, SPECIAL and 89 will issue a Request Service Message (if enabled by the RQS Mask). When the Generator issues the Request Service Message, the controller could be programmed to send the instrument into remote, execute the learn function, and return the Generator to local, ready to receive the next front-panel setup. For more information refer to the detailed operating instruction entitled "HP-IB RQS MASK".

Related Functions

HP-IB "Fast" Learn Mode



HP-IB REMOTE STEPPED SWEEP (Program Codes Y0, Y1, Y2, and Y3)

Description

This instruction details how to remotely execute an RF or a modulation frequency sweep via the HP-IB. The Remote Stepped Sweep (RSS) mode allows the controller to synchronize other system activities with each step of the Generator's sweep.

In the Remote Stepped Sweep mode, the controller must send one program code for each step of the sweep. Sweep time is dependent upon the controller's program execution time.

Most RF and Modulation sweep functions that are accessible from the front panel, are available in RSS. The exceptions are: the selectable Time/Step settings and sweep modes (Auto, Manual, and Single) which do not apply to this mode. For more information regarding frequency sweep modes, refer to the detailed operating instructions listed under RF Sweep and Modulation Sweep (Special Function 41).

Procedure

To configure the Generator in the Remote Stepped Sweep mode with a swept frequency display (displays each sweep step), the controller must send the program code Y1.

To configure the Generator in the Remote Stepped Sweep mode with a static frequency display (sweep limits displayed only), send the program code Y2.

To execute one step of the sweep, send the program code Y3 (RSS Execute).

To reset the frequency readout and disable the Remote Stepped Sweep mode, send the program code Y0.

NOTE

When the Generator first receives the Y1 or Y2 program code, the frequency readout will change to a swept display format. The actual output frequency, however, will not change to the designated start frequency until the first Y3 (RSS Execute) program code is received. Subsequent Y3 program codes will cause sweep execution.

Example

Configure the Generator in the Remote Stepped Sweep mode (with swept display) and execute 100 sweep steps.

Controller	Program Statements
HP-85 (BASIC)	OUTPUT 719; "Y0 Y1 Y3" FOR X = 1 TO 100 OUTPUT 719; "Y3" NEXT X
HP 9825 (HPL)	wrt 719, "Y0 Y1 Y3" for X = 1 to 100 wrt 719, "Y3" next X

Comments

Sweep time can be as fast as 700 us per step when in the Remote Stepped Sweep (with static display) mode. When Y1 (RSS with swept display) is used, sweep time per step is about 1.5 ms slower.

The Generator's Remote Stepped Sweep parameters, unless otherwise specified, default to the SPAN FREQ mode with STEPS set to 100 when the RSS mode is enabled.



Any of the Generator's parameters can be changed during a Remote Stepped Sweep. If the value of the static RF frequency is changed, the Remote Stepped Sweep readout will be reset; the Generator's actual frequency, however, will not change. When the next Y3 (RSS Execute) program code is received, the readout will return to where it left off (plus one step).

Execution of the Remote Stepped Sweep can be synchronized to other system activities by use of the Generator's trigger capability. Refer to the operating instruction entitled "HP-IB Trigger Response".

Related Functions

RF Sweep

Modulation Sweep



HP-IB REQUEST SERVICE (RQS) MASK (Program codes @1 and RM)

Description

This instruction details how to set and read the Generator's Request Service (RQS) Mask. The value of the RQS Mask determines the specific Generator condition(s) that will cause the instrument to issue a Request Service Message.

During operation, the Generator updates the Status Byte register to reflect the instrument's current operating condition. Bits 1-6 and 8 of the Status Byte are then logically ANDed with the RQS Mask. If the resultant value is not equal to 0, the Generator sets bit 7 of the Status Byte true, which issues the Request Service Message (SRQ bus line true).

The following Status Byte conditions will cause the Generator to issue the Request Service Message if enabled by the RQS Mask:

READY: when the Generator has completed processing the data received from the controller.

ENTRY ERROR: when an invalid keystroke or program command occurs (that is, when the front-panel STATUS light turns on steady).

HARDWARE ERROR: when a hardware condition turns the STATUS light on (blinking) or the EXTERNAL SOURCE HI-LO lights turn on.

POWER-FAIL RESTART: when the Generator is returned to a power ON condition (from STANDBY or completely off).

PARAMETER OUT: when any parameter of the output signal is changed.

SWEEP END: when the last step of a sweep occurs.

OPERATOR REQUESTS RESPONSE: when Special Function 87 is executed.

Procedure

To set the RQS mask value, the controller must send the program code @1, followed by a data message consisting of one 8-bit byte (decimal 0-255).

To read the RQS mask value, the controller must first send the program code RM. When the controller performs a read operation, the Generator will send one 8-bit byte which is the RQS Mask's current value.

Example

Set the Generator's RQS Mask to 00100010 (decimal 34). (This enables the instrument to issue the Request Service Message when a Sweep End or Entry Error is encountered.)

Controller	Program Statement
HP-85 (BASIC)	OUTPUT 719 USING "#,K,B"; "@1", 34
HP 9825 (HPL)	wtb 719, "@1",34



Example

Read the Generator's RQS Mask value.

Controller	Program Statement
HP-85 (BASIC)	OUTPUT 719; "RM" ENTER 719 USING "#,B"; [user variable]
HP 9825 (HPL)	wrt 719, "RM" rdb 719, [user variable]

Comments

When the @1 program code (Set Mask) and its associated data message are sent, the Generator executes the command immediately and does not require an End-of-String message.

Special Function 00 (System Clear) will reset the RQS Mask value to zero. Also, if the instrument is turned ON from completely off or from the Standby state the RQS Mask value be reset to zero.

When the Generator receives the Read Mask command, it responds by sending a single binary word (8-bit byte) which is the value of the mask. The Generator then sets the EOI line true to terminate the message.

The Generator can send a Request Service Message in either the local or remote mode. However, in the local mode, it can only respond to two instrument conditions: 1) Power-Fail Restart and 2) Operator Requests Response (Special Function 87).

The Request Service Message is cleared after a serial poll has been executed by the controller.

BIT	8	7	6	5	4	3	2	1
BINARY WEIGHT	128	64	32	16	8	4	2	1
STATUS BYTE CONDITION	OPERATOR REQUESTS RESPONSE	REQUEST SERVICE MESSAGE	SWEEP END	PARAMETER OUT	POWER-FAIL RESTART	HARDWARE ERROR	ENTRY ERROR	READY
RQS* MASK	0	X**	0	0	0	0	0	0

* Bits 1-8 are set to zero after execution of power-up or a system clear.

** Don't care state.

Related Functions

HP-IB Status Byte



HP-IB STATUS BYTE

Description

This instruction details how to read the Generator's Status Byte register.

In normal operation, the Generator updates the Status Byte register to reflect the instrument's current operating condition. The 8-bit Status Byte can be used to cause a bus interrupt or simply be read to monitor the Generator's operating status.

The Status Byte indicates the following Generator conditions:

Bit	Condition	Description
1	READY	Set true when the Generator has completed processing an operation.
2	ENTRY ERROR	Set true when an invalid keystroke or program command occurs (that is, when the front-panel STATUS light turns on steady).
3	HARDWARE ERROR	Set true when a hardware condition turns the STATUS light on (blinking) or the EXTERNAL SOURCE HI-LO lights turn on.
4	POWER-FAIL RESTART	Set true when the Generator is returned to a power ON condition (from STANDBY or completely off).
5	PARAMETER OUT	Set true when any parameter of the output signal is changed.
6	SWEEP END	Set true when the last step of a sweep occurs.
7	RQS	Set true when any of the bits 1-6 or 8 of the Status Byte are true and if its corresponding bit of the RQS Mask is true. When true, the Generator sets the SRQ bus line true.
8	OPERATOR REQUESTS RESPONSE	Set true when Special Function 89 is executed.

Procedure

To read the Generator's Status Byte register, the controller must send the Serial Poll Enable bus command.

Example

Read the Generator's Status Byte register.

Controller	Program Statement
HP-85 (BASIC)	[user variable] = SPOLL(719)
HP 9825 (HPL)	rds (719) → [user variable]

Comments

The eight bits of the Status Byte are cleared under several sets of conditions:

Bit 1, the "Ready" bit, is cleared whenever the Generator is processing data received from the controller.

Bits 2 and 3, "Entry and Hardware Error" bits, are cleared only after the following conditions occur consecutively:

- a. The error condition is corrected.
- b. The STATUS Key Message is re-read.
- c. The Status Byte is re-read. (This reading will still show the error because it is cleared only after the reading.)



Bits 4, 5, 6, and 8 are set on transient conditions and are cleared after the Status Byte is read once.

Bit 7, the "RQS" bit, is cleared only after all bits that caused the Request Service Message are cleared. (Refer to the operating instruction entitled "HP-IB RQS MASK".)

NOTE

One additional situation can clear bit 7. If the RQS Mask is changed, for instance to all zeros, and one of the seven Status Byte conditions occur, bit 7 would go to the clear condition.

BIT	8	7	6	5	4	3	2	1
BINARY WEIGHT	128	64	32	16	8	4	2	1
STATUS BYTE CONDITION	OPERATOR REQUESTS RESPONSE	REQUEST SERVICE MESSAGE	SWEEP END	PARAMETER OUT	POWER-FAIL RESTART	HARDWARE ERROR	ENTRY ERROR	READY

Related Functions

HP-IB Request Service (RQS) Mask

HP-IB STATUS KEY MESSAGE (Program Code MS)

Description

This instruction details how to read the Generator's STATUS Key Message. The STATUS Key Message contains the same codes that would normally be displayed in the status block of the FREQUENCY readout when the STATUS key is pressed and held.

Sending the STATUS Key Message command to the Generator prompts the instrument to output a message string, eight characters in length, ending with a Carriage Return/Line Feed.

The codes represent entry errors and instrument malfunctions. The message is sent in the following format:



If more than one error code is active, only the smallest value will be displayed in the message.

The status codes are explained on the Generator's pull-out information card and in the detailed operating instructions entitled "Status" and "Special Functions".*

*Refer to Comments for a description of the data for the External Modulation Source data.

Procedure

To receive the Status key message from the Generator, the controller must first send the program code MS (STATUS Key Message) to the instrument. When the Generator is addressed to talk, it will output its status information onto the bus.

Example

Send the Status Key Message program code and receive the status information.

Controller	Program Statements
HP-85 (BASIC)	OUTPUT 719; "MS" ENTER 719; [string variable]
HP 9825 (HPL)	wrt 719, "MS" red 719, [string variable]

Comments

The Status and Hardware error codes are cleared only after the condition is corrected and the message has been re-read. External Modulation Input Level (HI-LO CODE) will equal 2 if the external source's modulation level is low, 1 if high and 0 if it is within limits.

The size of the string variable assigned to the STATUS Key Message must be set to a minimum dimension of eight elements.

Related Functions

Status

Modulation, External



HP-IB TRIGGER RESPONSE (Program Codes CT and TR)

Description

This instruction details how to enable the Generator to execute a preprogrammed operation upon receipt of a bus trigger message.

The controller enables the Generator to respond to the trigger message by sending the Configure Trigger (CT) program code followed by a "response" program code. When the Generator receives a trigger message, it will immediately perform the "response" operation.

Procedure

To enable the Generator to respond to the trigger message, the Configure Trigger (CT) program code must first be sent to the Generator, followed by the program code of the operation to be executed.

To execute the "response" operation, the controller must send the Trigger (TR) program code. The Generator will also respond to a Device Trigger or a Group Execute Trigger.

Example

Configure the Generator to execute a single sweep (W4) upon receipt of the Trigger message.

Controller	Program Statements
HP-85 (BASIC)	OUTPUT 719; "CT W4"
HP 9825 (HPL)	wrt 719, "CT W4"

Comments

The Trigger (TR) program code will cause the Generator to perform the assigned instruction as shown in the example, however, the Device Trigger or Group Execute Trigger command can decrease the overall execution time of the assigned function.

INCREMENT ↑ ↓**Description**

This instruction details how to increase or decrease parameter values in predetermined increment sizes. All value-selectable parameters, with the exception of the modulation sweep parameters, can be changed using the INCREMENT ↑ or ↓ keys.

Procedure

To set the size of the increment refer to the instruction entitled "Increment Setting".

To increment a parameter value, select its respective function key, then select the Increment ↑ or ↓ to change the parameter value by the selected increment.

Keys and Program Codes 

Keys	Codes
↑	UP
↓	DN
FREQUENCY	FR
AMPLITUDE	AP
AM	AM
FM	FM
PM	PM

Keys	Codes
START FREQ	FA
STOP FREQ	FB
SPAN FREQ	FS
SET SIZE	N3
MARKERS 1-5	X1-X5
MOD FREQ	MF

Indications

The value of the parameter displayed will increase (↑) or decrease (↓) according to the increments selected.

Comments

A parameter value will change once for each keystroke of the ↑ or ↓ keys, or about five times per second if the key is held down (local operation or with the rear-panel AUX connector).

A parameter's increment value can be displayed by first, selecting its respective function key, then pressing and holding the INCR SET key.

The INCREMENT ↑ ↓ keys are always enabled.

Increment execution can be done via the rear-panel AUX connector by applying a TTL negative-true (5 μs minimum) pulse to the appropriate pin (INCREMENT ↑, Pin 2 or INCREMENT ↓, Pin 3). If either pin is held low, the parameter value will change about five times per second. Refer to paragraph 3-12 for AUX connector configuration.

Related Functions

Increment Setting

Knob

Knob, Increments

Increment, Parameter Shift Keying

INCREMENT SETTING

Description

This instruction details how to set the increment step sizes for all value-selectable parameters.

Incrementing a parameter value can be controlled with the INCREMENT UP DN keys or the knob (in the increment mode).

The smallest increment for which a parameter may be changed is given as the parameter's resolution; listed in the function's respective operating instruction.

Increments can be selected for the following parameters:

FUNCTION Keys: FREQUENCY, AM, FM, ϕ M, MOD FREQ, and AMPLITUDE.

SWEEP Keys: START, STOP, SPAN, SET SIZE, as well as all of the MARKERS keys.

Procedure

Select function, INCR SET, Data, and Units.

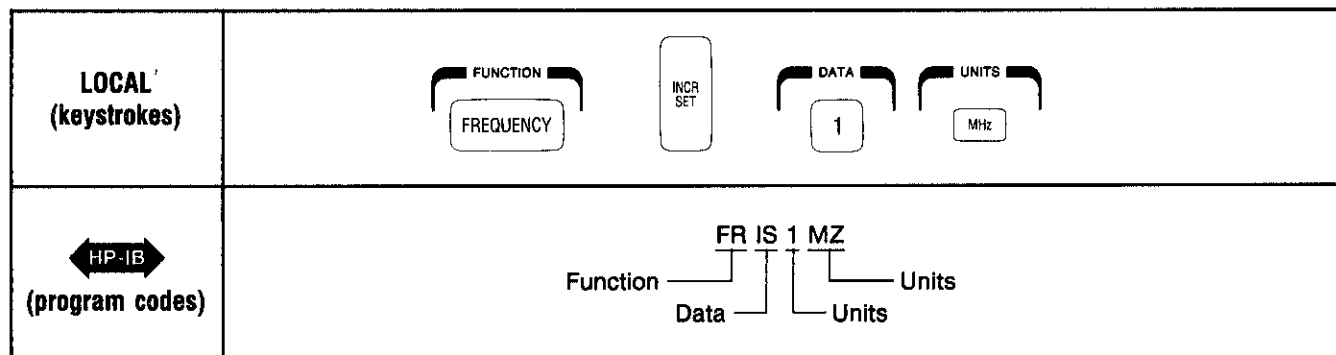

Keys and Program Codes

Keys	Codes
INCR SET	IS
KNOB INCR	R5
FREQUENCY	FR
AMPLITUDE	AP
AM	AM
FM	FM
ϕ M	PM
START FREQ	FA
STOP FREQ	FB
SPAN FREQ	FS

Keys	Codes
SET SIZE	N3
MARKERS 1-5	X1-X5
GHz	GZ
MHz	MZ
kHz	KZ
Hz	HZ
%	PC
dB	DB
mV	MV
μ V	UV
deg	DG

Indications

The value of the increment and its units annunciator will be displayed on the readout as the digits are entered. The readout will revert to its normal parameter function and value after the units are selected.

Comments

If the amplitude was selected in units of dBm, the increment must be selected in units of dB. If the amplitude was selected in units of volts, the increment must also be selected in units of volts (either mV or μ V).

Voltage increments can be selected with a maximum resolution 0.001 uV/Step. However, the Generator (in the Amplitude increment mode) only changes in 0.1 dB/step increments.

A parameter's increment value can be recalled to the readout by first, selecting its respective function key, then pressing and holding the INCR SET key.

Related Functions

Increment $\uparrow \downarrow$
Knob, Increment

INCREMENT, PARAMETER SHIFT KEYING (Special Functions 60, 61, and 62)

Description

This instruction details how to "toggle" a parameter value; that is one step up, then one step down using the instrument's \uparrow/\downarrow keys. This function is a variation of the Increment \uparrow/\downarrow feature.

Special Function 61 is a two-key format; the INCREMENT \uparrow key is enabled for one step up, then disabled while the INCREMENT \downarrow is enabled for one step down.

Special Function 62 is a one-key format; either key (UP or DN) will perform the complete toggle function.

Procedure

To enable the two-key format, select Blue Key, SPECIAL and 61.

To enable the one-key format, select Blue Key, SPECIAL and 62.

To toggle a parameter value, select its respective function key. Then, depending on the selected format, select one or both stepping keys (\uparrow , \downarrow).

To turn off either feature, select Blue Key, SPECIAL and 60.

Keys and Program Codes

Keys	Codes
Blue Key	BL
SPECIAL	SP
\uparrow	UP
\downarrow	DN
AMPLITUDE	AP

Note

The SPECIAL function can be programmed with a simple SP or with BL and AP (Blue Key and Amplitude).

Indications

The displayed parameter value will increase and decrease according to the size of the increment setting.

There is no indication that the parameter shift function has been enabled until the STATUS key is pressed and held, Code 61 or 62 will appear in the Special Function block of the Frequency readout.

Comments

This feature applies to all of the Generator's value-selectable functions with the exception of the modulation sweep functions.

Parameter shift keying always turns on with the up-step enabled regardless of the format that is selected.

The operator should consider switching to the uncorrected Amplitude mode (Special Function 85) when using the Parameter Shift Keying feature to control RF frequency (primarily in remote operation). The uncorrected mode can prevent excessive mechanical wear of the attenuator.

Toggling can be executed via the rear-panel AUX connector by applying a negative-true TTL pulse (5us minimum) applied to the appropriate pin. (INCREMENT ↑, Pin 2 or INCREMENT ↓, Pin 3). Refer to paragraph 3-12 for the description of the AUX connector configuration.

Related Functions

Increment ↑ ↓
Increment Setting

KNOB

Description

This instruction details how to increase or decrease any of the instrument's value-selectable parameters, with the exception of the modulation sweep parameters, using the Knob function.

The knob is a stepping control with an analog-like operation which can change a parameter value in incremental values. The increment sizes are determined by selecting the Knob increment mode (refer to the operating instruction entitled "Knob, Increment") or using the resolution keys.

The knob resolution is determined by the RESOLUTION keys times-ten and divide-by-ten.

Procedure

To increment a parameter value using the knob, select the function's respective key.

To enable the knob, select either of the ON keys; that is, the times-ten or divide-by-ten.

Selecting either key again will subsequently increase or decrease the knob's resolution by a factor of ten (depending on the key selected).

Rotate the knob clockwise to increase the parameter value. Rotate the knob counterclockwise to decrease the value.

To disable the knob, select the OFF key or select a different keyboard function.

Example

Enable the knob with 1 kHz/step resolution (assuming the FREQUENCY function key has already been selected and that the knob turns on with a resolution of 100 kHz/step).

LOCAL (keystrokes)	
 (program codes)	

Keys and Program Codes

Keys	Codes
ON X10	R1
ON 1/10	R2
OFF	R3
Knob, (cw)	RU
Knob, (ccw)	RD

Indications

Whenever the times-ten or divide-by-ten key is pressed and held down, the digit representing resolution flashes on and off (local mode only). When either key is pressed again, the adjacent (right or left) digit flashes to show the new resolution.

When the knob is turned clockwise, the displayed frequency value will increase in unit steps; starting at the selected digit. The inverse is true for counterclockwise rotation.

Comments

The knob is normally turned off whenever a new keyboard function is selected. There is a HOLD feature, however, that allows retention of knob control over one function, after shifting keyboard control to another. (See instruction for Knob, Hold).

The basic knob feature allows selection of the digit where the stepping will start. Knob rotation causes the progression of selected digit in units of one. Another feature allows the increment size to be chosen without regard to a starting digit. With this feature, the knob acts similarly to the INCREMENT \uparrow and \downarrow keys (refer to the instruction entitled KNOB, INCREMENT).

The knob rotation function can be performed using the rear-panel AUX connector. Special Function 95 converts the INCREMENT \uparrow (Pin 2) and INCREMENT \downarrow (Pin 3), on the connector, to Knob Clockwise and Knob Counterclockwise respectively.

Knob "otation" is executed by applying a negative-true (5 μ s minimum) TTL pulse to the appropriate pin on the AUX connector. Refer to paragraph 3-12 for a description of the AUX connector, Mode 1 configuration.

HP-IB

The knob function can be performed under HP-IB control. However, it requires a string of ten program codes (either RU or RD) to perform one step. The exceptions to this rule are: in Manual sweep mode, one program code produces one sweep step and when Special Function 94 or 95 is enabled, one program code will perform one step (refer to the operating instruction entitled "Knob Increment/Revolution").

In the remote mode, the knob does not need to be enabled before it will respond to "rotational" program codes. The program codes RU or RD will always cause "knob rotation".

Related Functions

Increment \uparrow \downarrow
Increment Setting
Knob Hold
Knob Increment
Knob, Increment/Revolution
Sweep Modes

KNOB HOLD

Description

This instruction details how to enable the Knob "Hold" feature. The HOLD feature allows retention of knob control over one function, even though another function has been selected.

Normally the knob feature applies to the function for which the front panel is set, and is disabled if another front-panel function is selected.

Procedure

To enable the knob hold function, select Blue Key and HOLD (×10).

Example

Enable the knob to vary amplitude; hold control of amplitude and shift front-panel control to FREQUENCY.

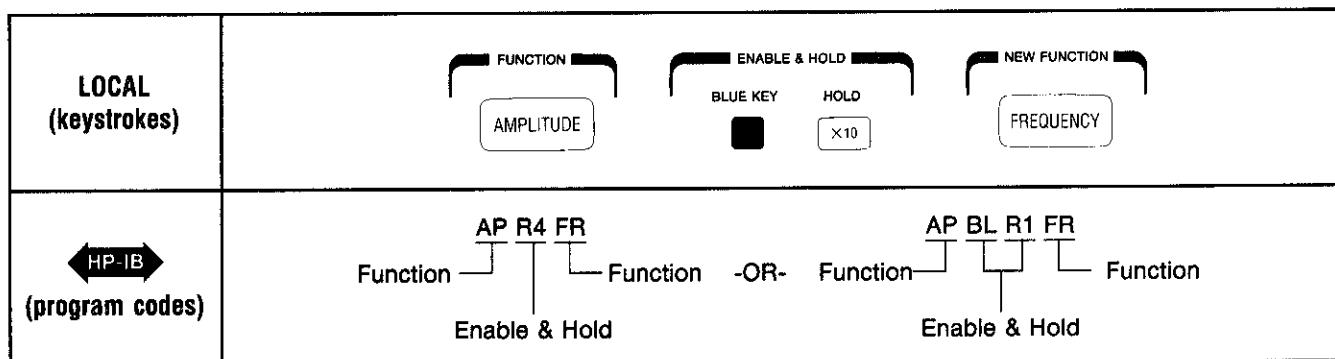

Keys and Program Codes

Keys	Codes
HOLD (×10)	R4

Indications

Knob control of the original function will still be evident.

Comments

Manual sweep mode takes priority over the HOLD feature; that is, the HOLD feature cannot be maintained if manual sweep is selected.

The HOLD feature cannot be maintained for one modulation function when front panel control is shifted to another modulation function (for example AM to FM or vice versa). The knob does remain enabled when the shift is made but the control shifts to the new modulation function.

The knob increment mode for one parameter can be "held" under knob control while a second parameter is incremented with the INCREMENT ↑ or ↓ keys.

Related Functions

- Knob
- Knob Increment

KNOB INCREMENT

Description

This instruction details how to use the knob to increase or decrease a parameter value in selected increments (similar to INCREMENT keys). The knob's normal resolution format is no longer applicable in this mode.

All value-selectable parameters, with the exception of the modulation sweep parameters, can be controlled with this feature.



Procedure

To increment a parameter value with the knob, select the respective function key and enter the desired increment value (refer to the operating instruction entitled "Increment Setting").

To enable the knob increment mode, select Blue Key and divide-by-ten (INCR ON).

Example

Enable the knob in the Increment (INC ON) configuration.

<p>LOCAL (keystrokes)</p>	
<p> (program codes)</p>	<p>R5 -OR- BL R2</p>

Keys and Program Codes

Keys	Codes
Blue Key	BL
INCR	R5
Divide-by-ten	R2

Indications

The displayed value will increase (cw) or decrease (ccw) according to the increments selected.

Comments

The knob is normally turned off whenever a new keyboard function is selected. The Hold feature, however, allows retention of knob control over one function after shifting keyboard control to another. (Refer to the instruction entitled "Knob Hold".)

The increment mode for a parameter can be "held" under knob control while a second function is incremented using the INCREMENT ↑/↓ keys.

In the Increment configuration, the knob acts essentially the same as the INCREMENT keys: cw (up), ccw (down).

A parameter's increment value can be recalled to the readout by first selecting the respective function key, then pressing and holding the INCR SET key.

The Increment function can also be performed using the rear-panel AUX connector after Special Function 95 (Knob, Increment/Revolution) is enabled. Execution of the Knob Increment function requires a negative-true (5 μ s minimum) TTL pulse applied to the appropriate pin (INCREMENT \uparrow , Pin 2 or INCREMENT \downarrow , Pin 3) of the connector. Refer to paragraph 3-12 for a description of the AUX connector configuration.



The knob increment function can be performed under HP-IB control, however, it requires a string of ten program codes (either RU or RD) to perform one increment. The exception to this rule is when Special Function 94 or 95 (Knob, Increment/Revolution) is enabled, where one program code will cause the Generator to perform one increment.

Related Functions

Increment $\uparrow \downarrow$

Increment Setting

Knob

Knob, Hold

Knob, Increment/Revolution

KNOB, INCREMENT/REVOLUTION (Special Functions 92, 94 and 95)

Description

This instruction details how to increase the Knob's resolution from 12 increments/revolution to 120 increments/revolution using Special Function 94.

Special Function 95 is identical to Special 94, however, in addition to the increased resolution, the rear panel AUX connector pins (INCREMENT UP and INCREMENT DN) are redefined as Knob Clockwise and Knob Counterclockwise, respectively.

Procedure

To increase the Knob's resolution to 120 increments/revolution, enter Special Function 94 or 95.

To return the knob resolution to 12 increments/revolution, enter Special Function 92.

Example

Increase Knob resolution to 120 increments/revolution.

LOCAL (keystrokes)	
 (program codes)	<div style="display: flex; justify-content: space-around;"> <div style="text-align: center;"> <p>SP 94</p> <p>Knob; 120 incr./rev.</p> </div> <div style="text-align: center;"> <p>SP 95</p> <p>Knob; 120 incr./rev., Reconfigure AUX connector</p> </div> </div>

Keys and Program Codes

All of the keys and program codes for this feature are shown in the example. Note: SPECIAL can be programmed with a simple SP or with BL and AP (Blue Key and AMPLITUDE).

Indications

There is no indication that this feature has been enabled until the STATUS key is pressed and held. Code 94 or 95 will appear in the Special Functions block of the FREQUENCY readout.

Comments

Knob resolution for the Manual Sweep mode is 120 increments/revolution whether or not Special 94 or 95 is enabled.

AUX connector reconfiguration defines INCREMENT ↑, Pin 2 and INCREMENT ↓, Pin 3 as KNOB CLOCKWISE and KNOB COUNTERCLOCKWISE, respectively.

Knob rotation can be executed via the rear-panel AUX connector by applying a negative-true (5 μs minimum) TTL pulse to the appropriate pin (120 pulses per revolution). Refer to paragraph 3-12 for a description of the AUX connector configuration.

Related Functions

Knob
Knob Hold
Knob Increment

MODULATION, INTERNAL AM

Description

This instruction details how to internally amplitude modulate the Generator's RF output. The internal modulation mode has selectable fixed or variable modulation rates.

Operating Characteristics:

Depth: 0-95%, (RF output level: -129.9 to +10 dBm).

AM Depth Resolution: 0.1%.

Fixed Rates: 400 Hz (INT 400) and 1000 Hz (INT 1k).

AM Rates:

Carrier Frequency (f_c)	Modulation Rate (Internal)
$150 \text{ kHz} \leq f_c < 1 \text{ MHz}$	10 Hz-1.5 kHz
$1 \text{ MHz} \leq f_c < 10 \text{ MHz}$	10 Hz-5.0 kHz
$10 \text{ MHz} \leq f_c < 2560 \text{ MHz}$	10 Hz-10.0 kHz

Modulation Frequency Resolution:

Modulation Frequency (f_{mod})	Modulation Frequency Resolution
$10 \text{ Hz} \leq f_{mod} < 100 \text{ Hz}$	0.1 Hz
$100 \text{ Hz} \leq f_{mod} < 1 \text{ kHz}$	1 Hz
$1 \text{ kHz} \leq f_{mod} < 10 \text{ kHz}$	0.01 kHz

Procedure

To enter the modulation depth, select AM, Data and %.

To enter the modulation frequency, select MOD FREQ, Data, and the appropriate units (Hz or kHz).

Example

Select amplitude modulation with 45% depth.

<p>LOCAL (keystrokes)</p>	
<p>HP-IB (program codes)</p>	

Example

Select an amplitude modulation frequency of 4 kHz.

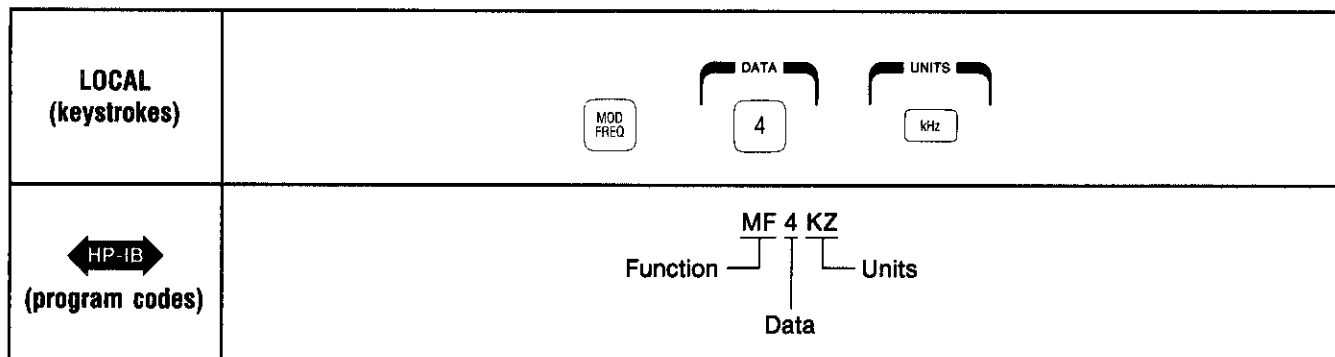

Keys and Program Codes

Keys	Codes
AM	AM
MOD FREQ	MF
FCTN OFF	FO
MOD OFF	MO
kHz	KZ
Hz	HZ
%	PC
INT 400	M1
INT 1k	M2
EXT AC	M3
EXT DC	M4

Indications

Selection of the AM function is indicated by the appropriate MODULATION (AM), "Arrow" annunciators. The entered AM depth is displayed on the MOD LEVEL readout expressed in percentage. The selected AM modulation frequency is displayed on the MOD FREQ display in units of Hz or kHz.

Comments

The modulation frequency can also be set using the internal fixed rates; 400 Hz (INT 400) or 1000 Hz (INT 1k).

To turn off AM modulation, select AM and FCTN OFF.

To turn all modulation off, select Blue Key and MOD OFF.

To turn AM on to the last selected parameters, select AM.

NOTE

After AM is turned off, if another modulation type and a new modulation frequency is selected, the AM modulation frequency value will change to the new setting if AM is turned on again.

Digits selected beyond the specified resolution for AM depth will be truncated. Leading zeros will be blanked.

Amplitude modulation is available above the rates shown in the table entitled "AM RATES"; AM distortion however, is not specified above those limits. When the RF output is amplitude modulated beyond the specified limits, simultaneous high depths and high rates will degrade AM performance.

AM is available with RF amplitudes greater than +10 dBm, however, AM distortion characteristics are unspecified above that level.

For information regarding AM modulation via external source, refer to the operating instruction entitled "Modulation, External AM".

Related Functions

Modulation, Mixed
Modulation, External AM
Increment, Parameter Shift Keying
Modulation Sweep
Increment $\uparrow \downarrow$
Knob

MODULATION, EXTERNAL AM

Description

This instruction details how to externally amplitude modulate the Generator's RF output via the AM IN connector. The external source can be ac- (EXT AC) or dc- (EXT DC) coupled to an external modulation source.

Operating Characteristics

Depth: 0-95% (RF output level; -129.9 to +10 dBm).

AM Depth Resolution: 0.1%.

AM IN input impedance: 600 ohms.

External AM Rates:

Carrier Frequency (f_c)	Modulation Rate (ac-Coupled)	Modulation Rate (dc-Coupled)
$150 \text{ kHz} \leq f_c < 1 \text{ MHz}$	10 Hz-1.5 kHz	dc-1.5 kHz
$1 \text{ MHz} \leq f_c < 10 \text{ MHz}$	20 Hz-5.0 kHz	dc-5.0 kHz
$10 \text{ MHz} \leq f_c < 2560 \text{ MHz}$	20 Hz-10.0 kHz	dc-10.0 kHz

Procedure

To enable the AM IN connector, select AM and EXT AC or EXT DC.

To enter a modulation depth, select Data and Units.

Adjust the external modulation signal level to 1 Vpk (0.707 Vrms). This signal level will cause the RF carrier's modulation depth to correspond with the level indicated on the MOD LEVEL readout. (Modulation depth is proportional to the external modulation signal level.)

NOTE

The EXT MOD HI light turns on if the signal is greater than 1.02 Vpk (0.721 Vrms). The LO light turns on if the signal is less than 0.98 Vpk (0.693 Vrms). If greater accuracy is required, an external voltmeter must be used.

Example

Select an external dc-coupled source with an AM modulation depth of 25 percent.

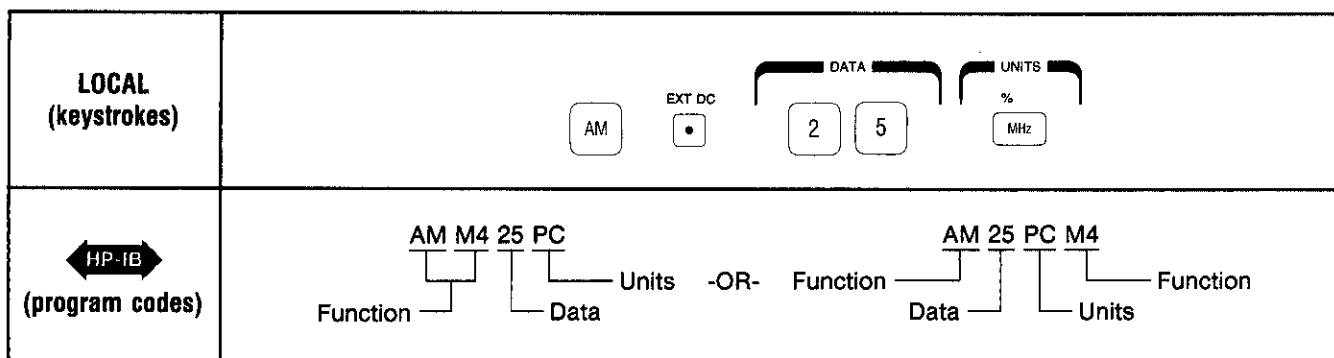

Keys and Program Codes 

Keys	Codes
EXT AC	M3
EXT DC	M4
AM	AM
Percent	PC
FCTN OFF	FO

Indications

Selection of the External AM function is indicated by the appropriate annunciators: MODULATION (AM) "Arrow", Coupling (EXT AC or EXT DC) and EXT MOD (HI-LO). The entered AM depth is shown on the MOD LEVEL display expressed in units of percent. The MOD FREQ display will be blanked.

Comments

Digits selected beyond the specified resolution for AM depth will be truncated; leading zeros will be blanked.

To turn off external amplitude modulation, select AM and FCTN OFF.

To turn off all modulation circuitry, select Blue Key and MOD OFF.

To turn on the modulation circuitry to the last selected external AM parameters, select AM.

To turn off external AM and turn on internal AM, select AM and MOD FREQ or INT 400 or INT 1k.

Amplitude modulation is available above the rates shown in the table entitled "EXTERNAL AM RATES"; AM distortion however, is not specified above those limits. When the RF output is amplitude modulated beyond the specified limits, simultaneous high depths and high rates will degrade AM performance.

AM is available with RF amplitudes greater than +10 dBm, however, AM distortion characteristics are unspecified above that level.

Related Functions

Modulation, Internal AM

Modulation, Mixed

MODULATION, INTERNAL FM

Description

This instruction details how to internally frequency modulate the Generator's RF output. The internal modulation mode has selectable fixed and variable modulation rates.

Operating Characteristics

Fixed Rates: 400 Hz (INT 400) or 1.0 kHz (INT 1k).

Variable Rates: 10 Hz to 99.9 kHz.

Modulation Frequency Resolution:

Modulation Frequency (f_{mod})	Modulation Frequency Resolution
$10 \text{ Hz} \leq f_{mod} < 100 \text{ Hz}$	0.1 Hz
$100 \text{ Hz} \leq f_{mod} < 1 \text{ kHz}$	1 Hz
$1 \text{ kHz} \leq f_{mod} < 10 \text{ kHz}$	0.01 kHz
$10 \text{ kHz} \leq f_{mod} < 99.9 \text{ kHz}$	0.1 kHz

FM Deviation Resolution:

Carrier Frequency (f_c)	Deviation Resolution	
	FM Deviation $\leq 100 \text{ kHz}$	FM Deviation $> 100 \text{ kHz}$
$0.1 \leq f_c < 640 \text{ MHz}$	0.1 kHz	N/A
$640 \leq f_c < 1280 \text{ MHz}$	0.2 kHz	1.0 kHz
$1280 \leq f_c < 2560 \text{ MHz}$	0.4 kHz	1.0 kHz

FM DEVIATION:

Carrier Frequency (f_c)	Maximum Peak Deviation*
	the smaller of:
$0.1 \leq f_c < 120 \text{ MHz}$	100 kHz or $f_{mod} \text{ (kHz)} \times 500$
$120 \leq f_c < 160 \text{ MHz}$	25 kHz or $f_{mod} \text{ (kHz)} \times 125$
$160 \leq f_c < 320 \text{ MHz}$	50 kHz or $f_{mod} \text{ (kHz)} \times 250$
$320 \leq f_c < 640 \text{ MHz}$	100 kHz or $f_{mod} \text{ (kHz)} \times 500$
$640 \leq f_c < 1280 \text{ MHz}$	200 kHz or $f_{mod} \text{ (kHz)} \times 1000$
$1280 \leq f_c < 2560 \text{ MHz}$	400 kHz or $f_{mod} \text{ (kHz)} \times 2000$

*See Comments

Procedure

To enter the amount of peak deviation, select FM, Data and kHz ("kHz" is the only valid unit).

To enter the modulation frequency, select MOD FREQ, Data and Units.

Example

Select an FM peak deviation of 25 kHz.

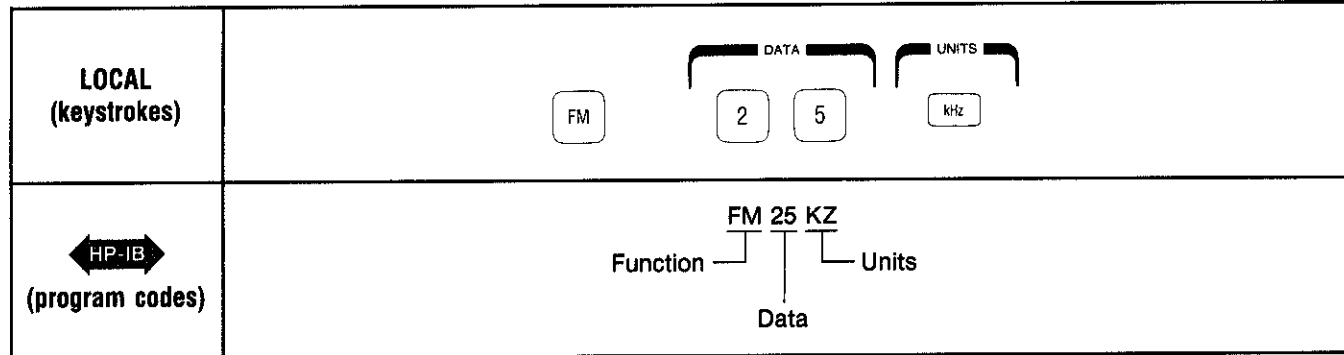

Example

Select an FM modulation frequency of 10 kHz.

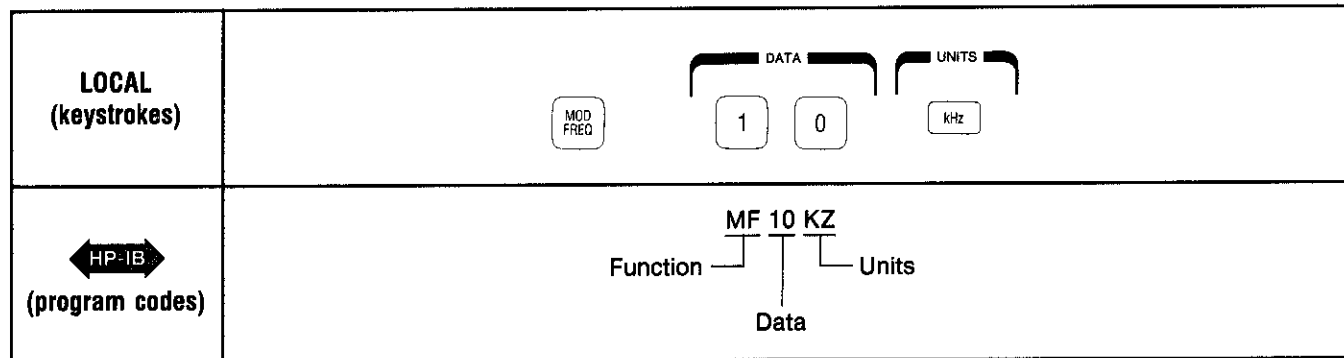

Keys and Program Codes

Keys	Codes
FM	FM
MOD FREQ	MF
FCTN OFF	FO
MOD OFF	MO
kHz	KZ
Hz	HZ
INT 400	M1
INT 1k	M2

Indications

Selection of the FM function is indicated by the appropriate MODULATION (FM) and "Arrow" annunciator. The entered FM deviation is shown on the MOD LEVEL display expressed in units of kHz. The selected FM modulation frequency is displayed on the MOD FREQ display in units of Hz or kHz.

Comments

The Generator's maximum peak deviation becomes proportionately dependent upon the modulation frequency, f_{mod} when the Generator is operated in the internal or EXT AC modulation mode. Dependence occurs when the modulation frequency, f_{mod} is decreased below a specified level; these levels are unique to each carrier-frequency band as shown in the FM DEVIATION table.

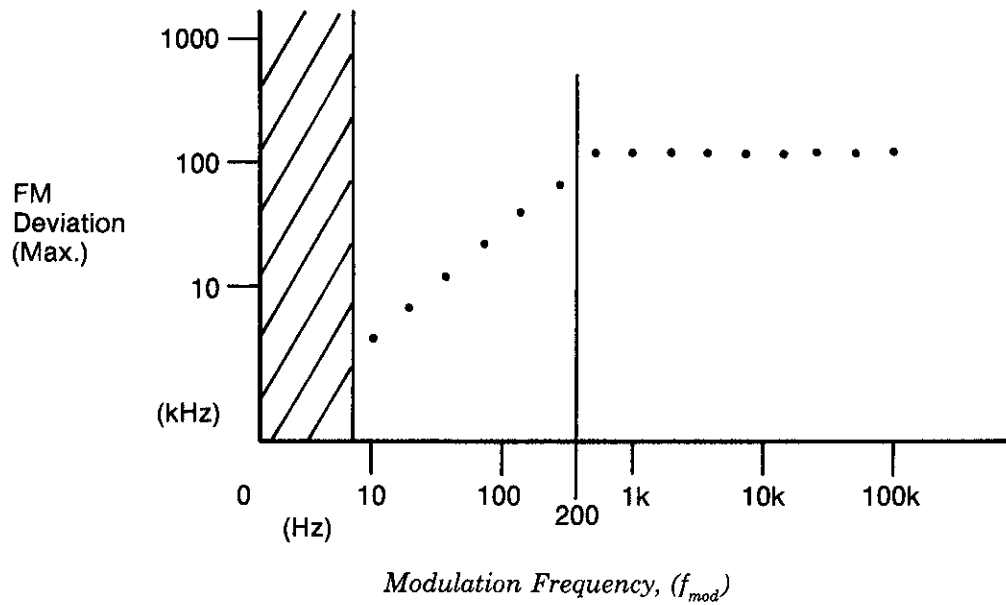

Plot illustrates Maximum FM Deviation vs. Modulation Frequency for frequency band 0.01 MHz-120 MHz or 320 MHz-640 MHz.

To turn off FM modulation, select FM and FCTN OFF.

To turn off all modulation circuitry, select Blue Key and MOD OFF.

To turn on the modulation circuitry to the last selected FM parameters, select FM.

NOTE

After FM is turned off, if another modulation type and a new modulation frequency is selected, the FM modulation frequency value will change to the new setting if FM is turned on again.

Related Functions

Modulation, Sweep
 Increment, Parameter Shift Keying
 Modulation, External FM
 Modulation, External AUX FM
 Modulation, Mixed
 Modulation Sweep
 Increment \uparrow \downarrow
 Knob

MODULATION, EXTERNAL FM

Description

This instruction details how to externally frequency modulate the Generator's RF output via the instrument's FM IN connector.

The FM IN input may be ac- (EXT AC) or dc- (EXT DC) coupled to an external modulation source.

NOTE

The Generator does not remain phase locked when the FM IN connector is dc-coupled.

Operating Characteristics

FM Rates: 20 Hz to 100 kHz (External ac-coupled).

(1 dB Bandwidth) dc to 100 kHz (External dc-coupled).

FM IN input impedance: 600 ohms.

FM Deviation Resolution:

Carrier Frequency (f_c)	Deviation Resolution	
	FM Deviation < 100 kHz	FM Deviation > 100 kHz
$0.1 \leq f_c < 640$ MHz	0.1 kHz	N/A
$640 \leq f_c < 1280$ MHz	0.2 kHz	1.0 kHz
$1280 \leq f_c < 2560$ MHz	0.4 kHz	1.0 kHz

FM Deviation:

Carrier Frequency (f_c)	Maximum Peak Deviation* (ac-coupled)
	the smaller of:
$0.1 \leq f_c < 120$ MHz	100 kHz or f_{mod} (kHz) \times 500
$120 \leq f_c < 160$ MHz	25 kHz or f_{mod} (kHz) \times 125
$160 \leq f_c < 320$ MHz	50 kHz or f_{mod} (kHz) \times 250
$320 \leq f_c < 640$ MHz	100 kHz or f_{mod} (kHz) \times 500
$640 \leq f_c < 1280$ MHz	200 kHz or f_{mod} (kHz) \times 1000
$1280 \leq f_c < 2560$ MHz	400 kHz or f_{mod} (kHz) \times 2000

*See Comments

FM Deviation:

Carrier Frequency (f_c)	Maximum Peak Deviation (dc-coupled)
$0.1 \leq f_c < 120$ MHz	100 kHz
$120 \leq f_c < 160$ MHz	25 kHz
$160 \leq f_c < 320$ MHz	50 kHz
$320 \leq f_c < 640$ MHz	100 kHz
$640 \leq f_c < 1280$ MHz	200 kHz
$1280 \leq f_c < 2560$ MHz	400 kHz

Procedure

To enable the FM IN connector, select FM and EXT AC or EXT DC.

To enter a specified frequency deviation, select Data and Units.

Adjust the external modulation signal-level to 1 Vpk (0.707 Vrms). This signal level causes the peak deviation of the RF carrier to correspond with the level indicated on the MOD LEVEL readout. (FM deviation is proportional to the external modulation signal level.)

NOTE

The EXT MOD HI light turns on if the signal is greater than 1.02 Vpk (0.721 Vrms). The LO light turns on if the signal is less than 0.98 Vpk (0.693 Vrms). If greater accuracy is required, an external voltmeter must be used.

Example

Select an external dc-coupled source with an FM peak deviation of 25 kHz.

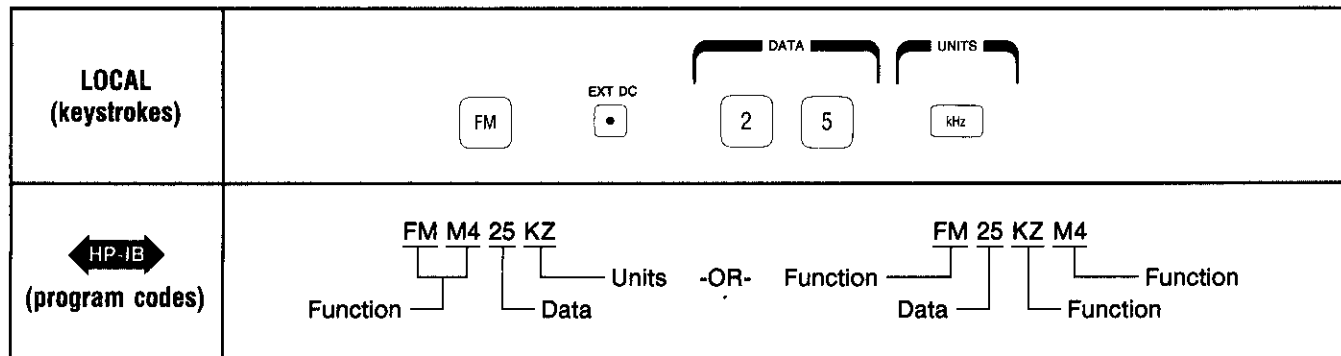

Keys and Program Codes

Keys	Codes
EXT AC	M3
EXT DC	M4
FM	FM
kHz	KZ
Hz	HZ
FCTN OFF	FO

Indications

Selection of the External FM function is indicated by the MODULATION (FM), "Arrow", coupling (EXT AC or EXT DC) and EXT MOD (HI-LO) annunciators.

The entered FM peak deviation is shown on the MOD LEVEL display, expressed in units of kHz. The MOD FREQ display will be blanked.

Comments

The Generator's maximum peak deviation becomes proportionately dependent upon the modulation frequency, f_{mod} when the Generator is operated in the external ac-coupled mode. Dependence occurs when the modulation frequency, f_{mod} is decreased below a specified level; these levels are unique to each RF frequency band. See the graph in the operating instruction entitled "Modulation, Internal FM".

The FM DEVIATION table shows the relationship between modulation frequency, maximum peak deviation and RF frequency.

To turn off external frequency modulation, select FM and FCTN OFF.

To turn off all modulation circuitry, select Blue Key and MOD OFF.

To turn on the modulation circuitry to the last selected External FM parameters, select FM.

To turn off external FM and turn on internal modulation, select FM and MOD FREQ. or INT 400 or INT 1k.

Related Functions

Modulation, Internal FM

Modulation, External AUX FM

Modulation, Mixed

MODULATION, EXTERNAL AUX FM (Special Functions 50 and 51)

Description

This instruction details how to externally frequency modulate the Generator's RF output via the rear-panel AUX FM IN input connector.

NOTE

The Generator remains phase locked when using the AUX FM connector to modulate the RF signal.

Operating Characteristics

FM Rates: dc — 100 kHz (refer to Comments).

AUX FM IN input impedance: 5000 ohms.

Coupling: dc-coupled (refer to Comments).

FM Deviation:

Carrier Frequency (f_c)	Maximum Peak Deviation
$0.1 \leq f_c < 120$ MHz	100 kHz
$120 \leq f_c < 160$ MHz	25 kHz
$160 \leq f_c < 320$ MHz	50 kHz
$320 \leq f_c < 640$ MHz	100 kHz
$640 \leq f_c < 1280$ MHz	200 kHz
$1280 \leq f_c < 2560$ MHz	400 kHz

Carrier Frequency (f_c)	Aux FM Input Sensitivity* (peak dev./ V_{pk})
$0.1 \leq f_c < 120$ MHz	25 kHz/V
$120 \leq f_c < 160$ MHz	6.25 kHz/V
$160 \leq f_c < 320$ MHz	12.5 kHz/V
$320 \leq f_c < 640$ MHz	25 kHz/V
$640 \leq f_c < 1280$ MHz	50 kHz/V
$1280 \leq f_c < 2560$ MHz	100 kHz/V
*Modulation signal-level must not exceed $4 V_{pk}$. For V_{rms} , multiply V_{pk} by 0.707.	

Procedure

To enable the AUX FM IN connector, select Blue Key and Special 51.

Adjust the signal level of the external source to produce the desired peak deviation. (Refer to the AUX FM IN Input Sensitivity described in the table entitled "MODULATION SIGNAL LEVEL").

To disable the AUX FM IN connector, select Blue Key, Special and 50.

Example

Frequency modulate the RF signal with a peak deviation of 25 kHz using the AUX FM IN connector. (RF output frequency set to 100 MHz.)

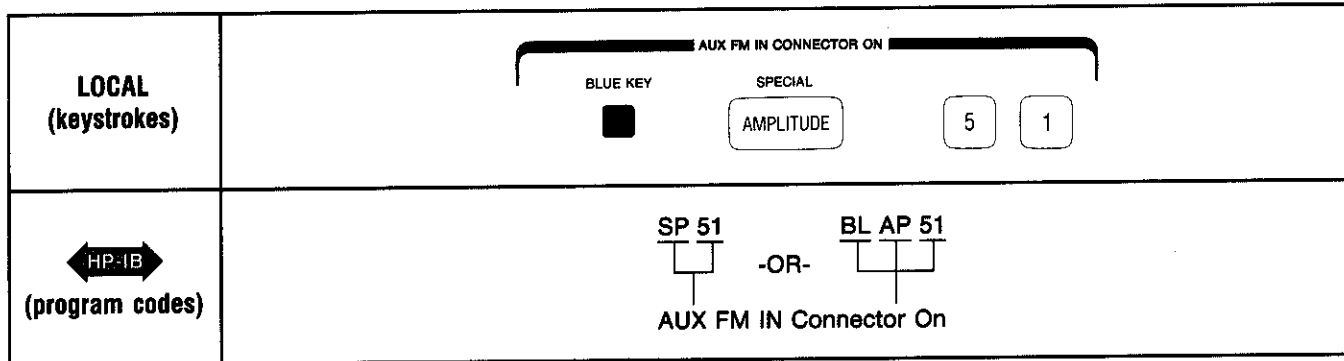

Adjust external modulation signal-level to 1 Vpk.

Keys and Program Codes ↔ HP-IB ↔

All of the keys and codes for this feature are shown in the example. Note: SPECIAL can be programmed with a simple SP or with BL and AP (Blue Key and Amplitude).

Indications

Enabling Special Function 51 will turn on the FM circuitry and recall the last selected FM parameters.

There is however, no other indication that the AUX FM IN connector has been enabled until the STATUS key is pressed and held. Code 51 will appear in the Special Function block of the FREQUENCY display.

Comments

NOTE

The Generator remains phase locked when using the AUX FM connector to modulate the RF signal. When the AUX FM IN connector is used for FM + FM, the resulting deviation from all sources must not exceed the maximum limits shown in the table entitled "Maximum Peak Deviation".

The AUX FM IN connector always is dc-coupled.

NOTE

The AUX FM IN signal-path bypasses the internal level-control circuitry. Thus, the voltage level of the external signal source determines the amount of FM peak deviation.

Turning off FM (selecting FM and FCTN OFF) does not disable Special Function 51, however, the AUX FM input signal will be disconnected from the modulation circuitry.

If AUX FM IN function is disabled (Special Function 50), the Generator will continue to display the last-selected FM parameters.

Related Modulation Functions

- Modulation, Internal FM
- Modulation, External FM
- Modulation, Mixed

MODULATION, INTERNAL PHASE MODULATION (ϕ M)

Description

This instruction details how to internally phase modulate the Generator's RF output. The internal modulation mode has selectable fixed and variable modulation rates.

Operating Characteristics

Fixed Rates: 400 Hz (INT 400) and 1.0 kHz (INT 1k).

Variable Internal Rates:

Carrier Frequency (f_c)	Modulation Rate
$0.15 \text{ MHz} \leq f_c < 10 \text{ MHz}$	10 Hz-10 kHz
$10 \text{ MHz} \leq f_c < 100 \text{ MHz}$	10 Hz-99.9 kHz

Phase Deviation:

Carrier Frequency (f_c)	Maximum Peak Deviation (degrees)	Resolution (degrees)
$0.1 \leq f_c < 120 \text{ MHz}$	100	1
$120 \leq f_c < 160 \text{ MHz}$	25	1
$160 \leq f_c < 320 \text{ MHz}$	50	1
$320 \leq f_c < 640 \text{ MHz}$	100	1
$640 \leq f_c < 1280 \text{ MHz}$	200	2
$1280 \leq f_c < 2560 \text{ MHz}$	400	4

Modulation Resolution:

Modulation Frequency (f_{mod})	Modulation Frequency Resolution
$10 \text{ Hz} < f_{mod} \leq 100 \text{ Hz}$	0.1 Hz
$100 \text{ Hz} < f_{mod} \leq 1 \text{ kHz}$	1 Hz
$1 \text{ kHz} < f_{mod} \leq 10 \text{ kHz}$	0.01 kHz
$10 \text{ kHz} < f_{mod} \leq 99.9 \text{ kHz}$	0.1 kHz

Procedure

To enter the amount of peak deviation, select ϕ M, Data and Units ("deg" is the only valid unit).

To enter the phase modulation rate, select MOD FREQ, Data and Units.

Example

Select a ϕ M peak deviation of 25 degrees.

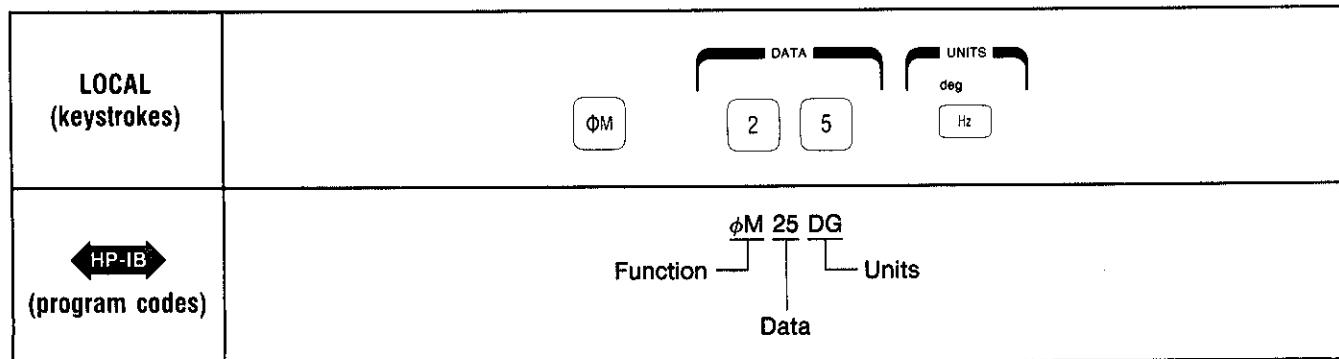

Example

Select an ϕ M modulation frequency of 10 kHz.

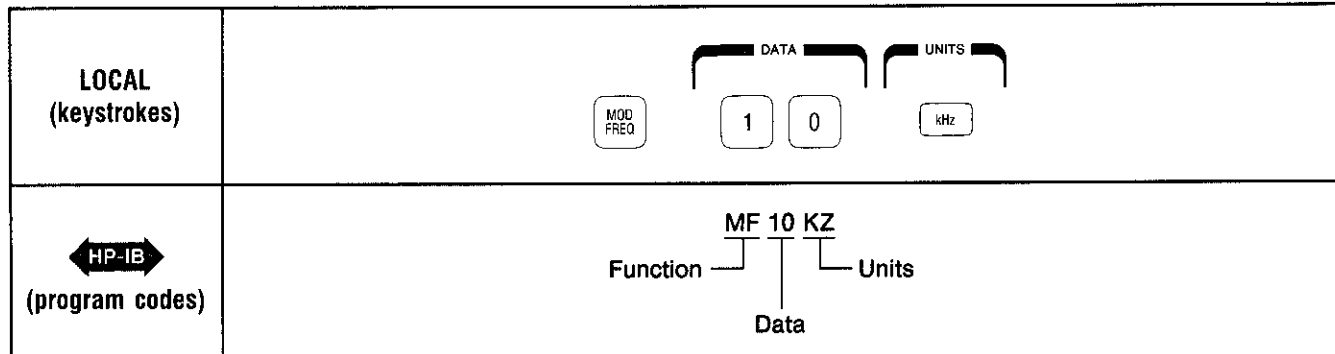

Keys and Program Codes

Keys	Codes
ϕ M	ϕ M
MOD FREQ	MF
DEG	DG
FCTN OFF	FO
MOD OFF	MO
kHz	KZ
Hz	HZ
INT 400	M1
INT 1k	M2
EXT AC	M3
EXT DC	M4

Indications

Selection of the ϕ M function is indicated by the appropriate MODULATION (ϕ M) and "Arrow" annunciator. The entered ϕ M deviation is shown on the MOD LEVEL display expressed in units of degrees. The selected ϕ M modulation frequency is displayed on the MOD FREQ display in units of kHz or Hz.

Comments

To turn off phase modulation, select ϕ M and FCTN OFF.

To turn off all modulation circuitry, select Blue Key and MOD OFF.

To turn on the modulation circuitry to the last selected ϕ M parameters, select ϕ M.

For information regarding phase modulation via an external source, refer to the operating instruction entitled "Modulation, External ϕ M".

Related Functions

- Internal, Parameter Shift Keying
- Modulation, External ϕ M
- Modulation, External Source
- Modulation, Mixed

MODULATION, EXTERNAL PHASE MODULATION (ϕ M) (Includes Special Function 70 and 71)

Description

This instruction details how to phase modulate the Generator's RF output with an external source via the ϕ M IN connector. The Generator can be ac- (EXT AC) or dc- (EXT DC) coupled to an external modulation source.

The input impedance of the ϕ M IN input port can be changed from 50 ohms to 600 ohms with Special Function 71.

Operating Characteristics

Phase Modulation Rates (minimum): None (dc- coupled).
 200 Hz (ac-Coupled into 50 ohms).
 20 Hz (ac-Coupled into 600 ohms).

External Input Signal Levels:

50 ohm input—1 Vpk (+10 dBm) into calibrated 50 ohms.
 600 ohm input—1Vpk(0.707 Vrms).

Phase Modulation Rates:

Carrier Frequency (f_c)	Maximum Modulation Rate
$0.1 \leq f_c < 120$ MHz	10 kHz
$120 \leq f_c < 160$ MHz	100 kHz
$160 \leq f_c < 320$ MHz	2 MHz
$320 \leq f_c < 2560$ MHz	10 MHz

Phase Deviation:

Carrier Frequency (f_c)	Maximum Peak Deviation (degrees)	Resolution (degrees)
$0.1 \leq f_c < 120$ MHz	100	1
$120 \leq f_c < 160$ MHz	25	1
$160 \leq f_c < 320$ MHz	50	1
$320 \leq f_c < 640$ MHz	100	1
$640 \leq f_c < 1280$ MHz	200	2
$1280 \leq f_c < 2560$ MHz	400	4

Procedure

To enable the External ϕ M IN connector, select PM and EXT AC or EXT DC.

To enter the amount of phase deviation, select Data and Units.

Adjust the external modulation signal level to 1 V_{pk} (0.707 V_{rms}). This signal level causes the phase deviation of the RF carrier to correspond with the level indicated on the MOD LEVEL readout.

NOTE

*The EXT MOD HI light turns on if the signal is greater than 0.721 V_{rms} (1.02 V_{pk}). The LO light turns on if the signal is less than 0.693 V_{rms} (0.98 V_{pk}). * If greater accuracy is required, an external voltmeter must be used.*

Example

Select an external dc-coupled source with a ϕM peak deviation of 25 degrees.

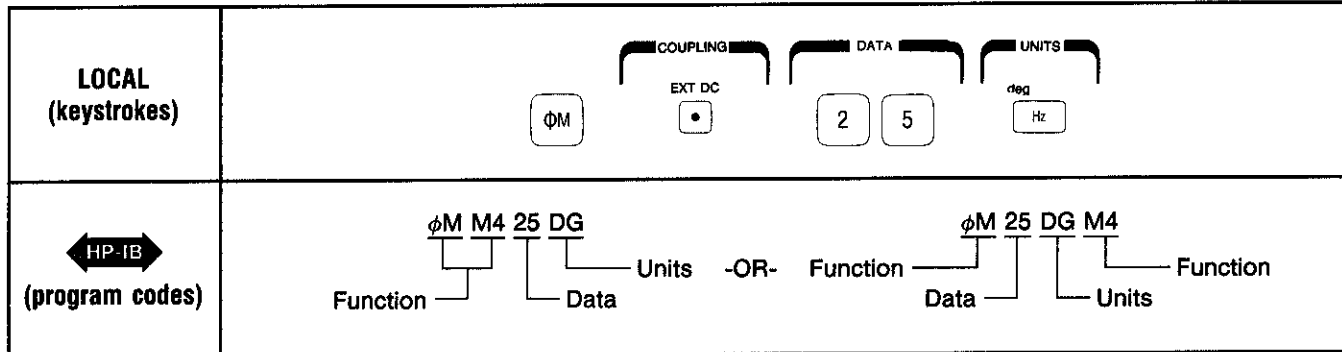

Keys and Program Codes

Keys	Codes	Keys	Codes
Blue Key	BL	EXT AC	M3
SPECIAL	SP	EXT DC	M4
kHz	KZ	ϕM	ϕM
Hz	HZ	MOD OFF	MO
		FCTN OFF	FO

*These voltage levels are only applicable when the input impedance is equal to 600 ohms.

Indications

Selection of the External PM function is indicated by the MODULATION (ϕM), "Arrow", Coupling (EXT AC or EXT DC) and EXT MOD (HI-LO) annunciators. The entered ϕM deviation is shown on the MOD LEVEL display expressed in units of degrees. The MOD FREQ display will be blanked.

Comments

To turn off external phase modulation, select ϕM and FCTN OFF.

To turn off all modulation circuitry, select Blue Key and MOD OFF.

To turn on the modulation circuitry to the last selected External oM parameters, select ϕM .

To turn off external phase modulation and turn on internal phase modulation, select ϕM and MOD FREQ, INT 100 or INT 1K.

The ϕM IN input impedance can be changed from 50 ohms to 600 ohms by selecting Blue Key, SPECIAL and 71. The input impedance can be restored to 50 ohms by selecting Blue Key, SPECIAL and 70.

Related Functions

- Modulation, ϕM
- Modulation Mixed

MODULATION, PULSE

Description

This instruction details how to internally or externally pulse modulate the Generator's RF output. The internal modulation mode has selectable fixed or variable modulation rates.

Operating Characteristics:

Internal Modulation Frequency Range: 10 Hz to 99.9 kHz.

Internal Fixed Rates: 400 Hz (INT 400), 1 kHz (INT 1k).

External Modulation Frequency Range:

Carrier Frequency (f_c)	External Modulation Frequency
$50 \text{ MHz} \leq f_c < 640 \text{ MHz}$	10 Hz to 2 MHz
$f_c > 640 \text{ MHz}$	10 Hz to 5 MHz

Input Impedance: 50 ohms.

External Input Voltage Thresholds: Carrier "on"; greater than 2.5V

Carrier "off"; less than 0.5V.

(not to exceed +10V)

Minimum Pulse Width: 1 μ s for duty cycle < 50%.

Procedure

To enter a pulse modulation frequency, select PULSE, MOD FREQ, Data, and Units.

To enable the rear-panel pulse modulation input (PLS BPSK), select PULSE and EXT DC.

Example

Select an internal pulse modulation frequency of 50 kHz.

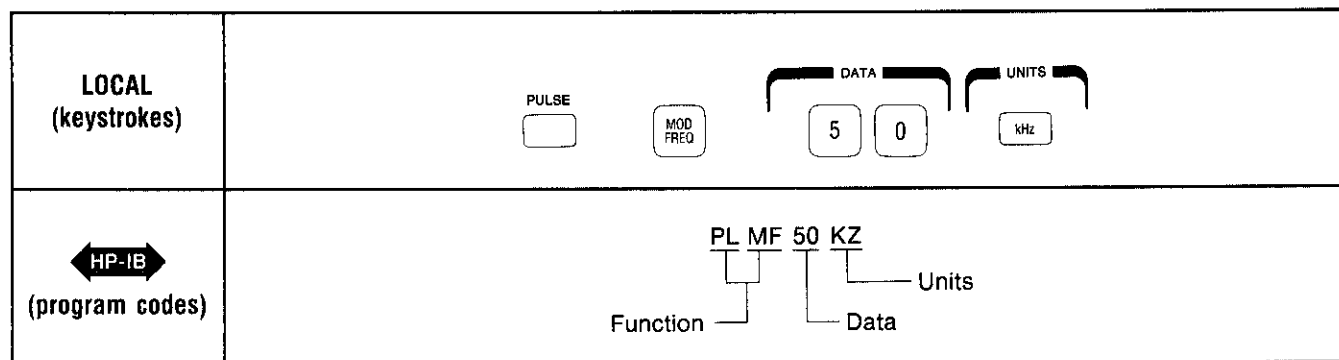

Keys and Program Codes 

Keys	Codes
PULSE	PL
MOD FREQ	MF
FCTN OFF	FO
MOD OFF	MO
kHz	KZ
Hz	HZ
INT 400	M1
INT 1k	M2
EXT DC	M4

Indications

Selection of the PULSE function is indicated by the appropriate MODULATION (PULSE) and "Arrow" annunciator. The selected pulse modulation frequency is displayed on the MOD FREQ readout in units of kHz or Hz. The MOD LEVEL display will read "---".

If the external modulation mode is selected, the MOD FREQ display will blank and the EXT MOD annunciator will light.

Comments

To turn pulse modulation off, select PULSE and FCTN OFF.

To turn all modulation circuitry off, select Blue Key and MOD OFF.

To turn on the modulation circuitry to its last selected PULSE parameters, select PULSE.

NOTE

After PULSE is turned off, if another modulation type and a new modulation frequency is selected, the PULSE modulation frequency value will change to the new setting if PULSE is turned on again.

To turn off external pulse modulation and turn on internal pulse modulation, select PULSE and MOD FREQ, INT 400 or INT 1K (recalls last selected internal modulation parameters).

PULSE and BPSK modulation are not available simultaneously. If PULSE is selected while BPSK is on, BPSK will be turned off and vice versa.

External ac- (EXT AC) coupling of a modulation source is not available in the pulse modulation mode.

Pulse modulation is possible when the RF frequency is less than 50 MHz, however, the Generator's modulation characteristics are unspecified below this rate.

Related Functions

Increment Setting

Increment ↑ ↓

Modulation Mixed

Modulation, Sweep

Internal, Parameter Shift Keying

MODULATION, BI-PHASE SHIFT KEYING

Description

This instruction details how to internally or externally bi-phase shift modulate the Generator's RF output. The internal modulation mode has selectable fixed or variable modulation rates.

Operating Characteristics:

Carrier Frequency: 120 MHz-640 MHz.
 120 MHz-2560 MHz (with Opt. 002).
 Phase Deviation: ±90 degrees only.
 Internal Modulation Frequency Range: 10 Hz-99.9 kHz.
 Internal Fixed Rates: 400 Hz (INT 400) or 1 kHz (INT 1k).
 External Modulation Frequency Range: dc-1 MHz.
 External Modulation Voltage Thresholds: Carrier "on", greater than 2.5V.
 Carrier "off", less than 0.5V.
 (Not to exceed +10V)

Input Impedance: 50 ohms.

Procedure

To enter the bi-phase modulation frequency, select BPSK, MOD FREQ, Data, and Units.

To enable the rear-panel PLS BPSK modulation input, select BPSK and EXT DC.

Example

Select a bi-phase modulation frequency of 50 kHz.

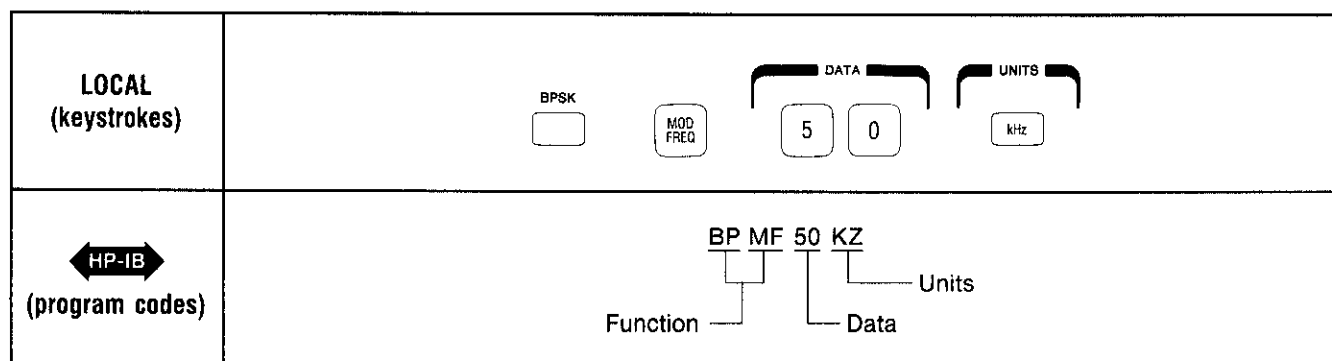

Keys and Program Codes **HP-IB**

Keys	Codes
BPSK	BP
MOD FREQ	MF
FCTN OFF	FO
MOD OFF	MO
kHz	KZ
Hz	HZ
INT 400	M1
INT 1k	M2
EXT DC	M4

Indications

Selection of the BPSK function is indicated by the appropriate MODULATION (BPSK) and "Arrow" annunciator. The selected bi-phase modulation frequency is displayed on the MOD FREQ readout in units of kHz or Hz, the MOD LEVEL display will read "---".

If the external modulation mode is selected, the MOD FREQ display will blank and the EXT MOD annunciator will light.

Comments

To turn the BPSK function off, select BPSK and FCTN OFF.

To turn all modulation circuitry off, select Blue Key and MOD OFF.

To turn on the modulation circuitry to the last selected bi-phase shift modulation parameters, select BPSK.

NOTE

After BPSK is turned off, if another modulation type and a new modulation frequency is selected, the BPSK modulation frequency value will change to the new setting if BPSK is turned on again.

To turn off external BPSK modulation and turn on the internal BPSK modulation, select BPSK and MOD FREQ, INT 400 or INT 1K (recalls last selected internal BPSK modulation parameters).

BPSK and PULSE are not available simultaneously. If BPSK is selected while PULSE is on, PULSE will be turned off and vice versa.

BPSK modulation is possible when the RF frequency is less than 120 MHz, however, the Generator's modulation characteristics are unspecified below this rate.

External ac-coupling (EXT AC) of a modulation source is not available in the bi-phase modulation mode.

Related Functions

Mixed Modulation
Modulation, Sweep
Parameter Shift Keying

MODULATION, MIXED

Description

This instruction details how to simultaneously modulate the Generator's RF signal with more than one modulation source. Modulation of the RF output signal can be done from internal as well as external sources.

Procedure

To determine which types of modulation are available simultaneously, reference should be made to the Mixed Modulation Matrix.

Each horizontal row of the matrix has elements which represent the modulation types that can be mixed with the type shown in the first column (designated by an asterisk).

The matrix does not imply that all of the designated modulation types (those appearing in the same row) are available concurrently. Therefore, all combinations of the modulation types to be mixed must be verified on the matrix.

Example

Modulate the Generator's RF signal with two types of modulation e.g. Internal AM and Internal FM.

Refer to the row labeled "Internal AM" on the matrix. Verify that the Generator can be simultaneously modulated with the Internal FM source.

Example

Modulate the Generator's RF signal with three types of modulation e.g. External AM, External FM, and Internal PULSE.

Refer to the row labeled "External AM" on the matrix. Verify that the Generator can be simultaneously modulated with the External FM source.

Refer to the row labeled "External FM" and verify that the Generator can be modulated with the Internal PULSE source.

Indications

Simultaneous modulation is indicated by the Generator's MODULATION annunciators (AM, FM, ϕ M, BPSK, and PULSE).

The "Arrow" annunciator designates the type of modulation that is associated with the data displayed on the MOD FREQ and MOD LEVEL readouts.

Comments

Reference should be made to the respective operating instructions for all modulation types being used. The Operating Characteristics describe the instrument's modulation limitations.

The modulation frequency of all internal modulation types (AM, FM, ϕ M, BPSK, and PULSE), is always equal to the value displayed on the MOD FREQ readout since the instrument has only one modulation oscillator.

Related Functions

Modulation, Internal AM
 Modulation, External AM
 Modulation, Internal FM
 Modulation, External FM
 Modulation, External AUX FM

Modulation, Internal ϕ M
 Modulation, External ϕ M
 Modulation, BPSK
 Modulation, PULSE

MIXED MODULATION MATRIX

	INT AM	EXT AM	INT FM	EXT FM	INT ϕ M	EXT ϕ M	INT BPSK	EXT BPSK	INT PLS	EXT PLS
INT AM		
EXT AM		
INT FM	.	.		¹
EXT FM	.	.	¹ .	²
INT ϕ M				³ .	.	.
EXT ϕ M			³ .	³ .	.	.
INT BPSK		³ .				
EXT BPSK	³ .	³ .				
INT PLS				
EXT PLS				

¹ Available only when the External AUX FM input (rear panel) is used as the external source input.

² EXT FM + EXT FM is available by using the external input connectors FM IN and AUX FM IN (rear panel).

³ PM and BPSK is available if the following conditions exist:

- a. RF frequency < 640 MHz.
- b. Either External ϕ M or Internal BPSK is selected, or vice versa. (The modulation type using an external source must be turned on before the one using the internal source.)

MODULATION OSCILLATOR (Special Functions 96 and 97)

Description

This instruction details how to turn on the Generator's modulation oscillator without modulating the Generator's RF signal.

The modulation oscillator's signal is available at the rear-panel VMO OUT connector.

Operating Characteristics

Modulation Oscillator Range: 10 Hz-99.9 kHz.

Output Signal Level: 1 Vpk into 600 ohms.

Output Impedance: 600 Ohms.

Procedure

To turn on the modulation oscillator, when all modulation functions are off, select the Blue Key, SPECIAL and 97.

To set the oscillator frequency, select MOD FREQ, Data and Units.

To turn the modulation oscillator off, select the Blue Key, SPECIAL and 96.

Example

Turn on the modulation oscillator.

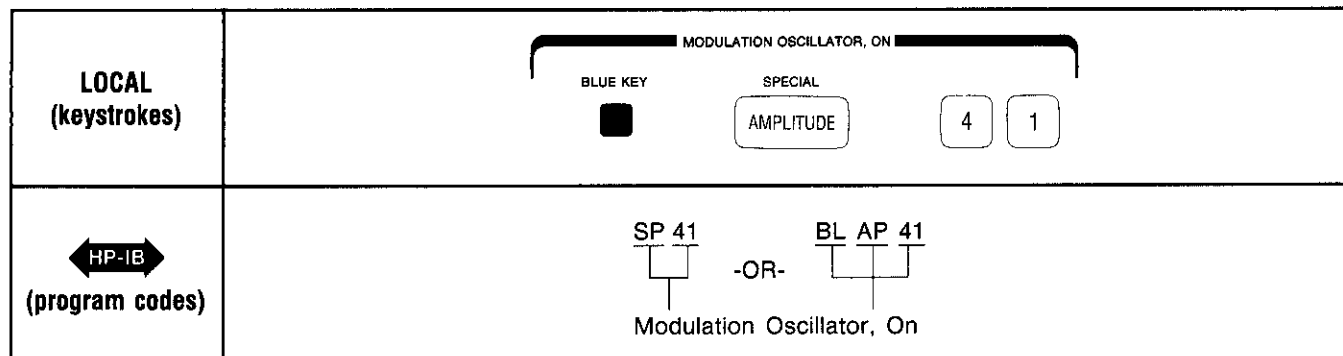

Example

Set the modulation oscillator frequency to 12.5 kHz.

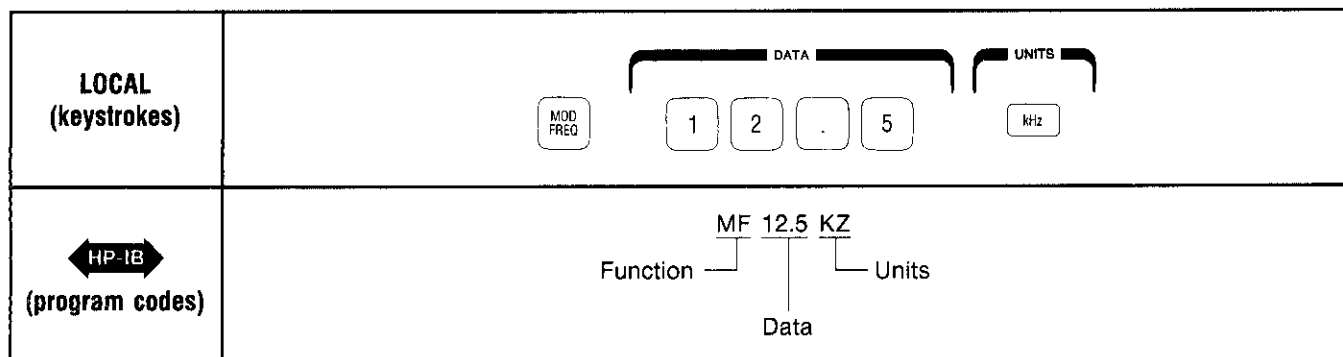

Keys and Program Codes 

Keys	Codes
MOD FREQ	MF
SPECIAL	SP
kHz	KZ
Hz	HZ

Indications

When the modulation oscillator is turned on, the MOD FREQ readout will display the oscillator's frequency in units of Hz or kHz. If the STATUS key is pressed and held, Code 97 will appear in the Special Functions block of the FREQUENCY readout.

Comments

If any of the modulation functions are on (i.e. AM, FM, etc.) the modulation oscillator signal will be present at the VMO OUT connector whether or not Special Function 97 is enabled.

Special Function 00 or 96 must be used to turn the modulation oscillator off; selecting MOD FREQ and FCTN OFF will only turn the MOD FREQ display off.

The modulation oscillator has the capability to be frequency-swept over its entire frequency range. Refer to the Modulation Sweep operating instructions.

Related Functions

Modulation Sweep
Modulation Sweep Modes
Modulation Sweep, Start-Stop
Modulation Sweep, Span
Modulation Sweep, Step Size
Modulation Sweep, Time/Step

MODULATION SWEEP (Special Functions 40 and 41)

Description

This instruction details how to enable the Generator's Modulation Sweep Mode.

The instrument's modulation oscillator frequency changes in discrete steps rather than in a continuous analog manner.

The modulation frequency may be swept in either a linear or logarithmic mode over the frequency range of 10 Hz to 99.9 kHz.

The following parameters are value-selectable:

Start-Stop frequencies	Center Frequency and Span
Time/Step	Sweep Step Size ($\Delta F/\text{step}$)

Procedure

To enable the Modulation Sweep function, select Blue Key, SPECIAL and 41.

To disable the Modulation Sweep function, select Blue Key, SPECIAL and 40.

Example

Enable the Modulation Sweep function.

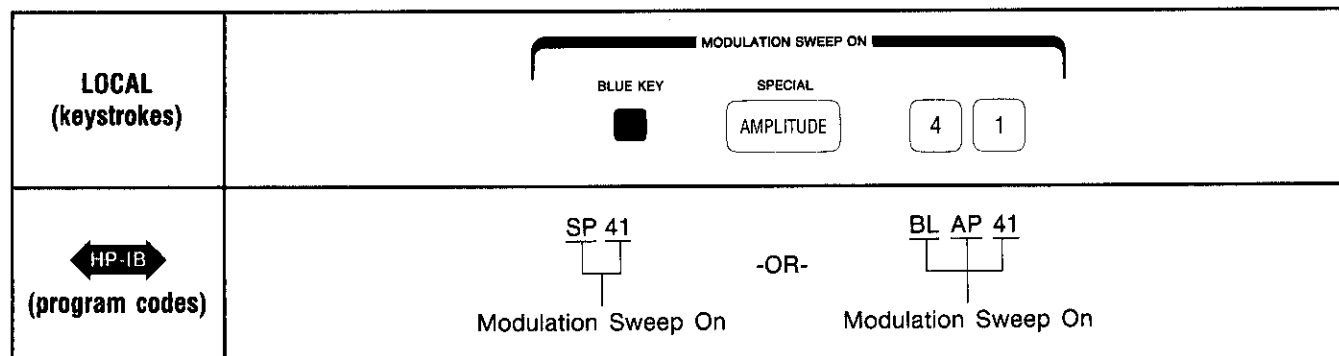

Keys and Program Codes

All of the keys and codes for this feature are shown in the example. Note: SPECIAL can be programmed with a simple SP or with BL and AP (Blue Key and Amplitude).

Indications

There is no apparent indication that the Modulation Sweep function has been enabled until the STATUS key is pressed and held. Code 41 will appear in the Special Functions block of the FREQUENCY readout.

Comments

Sweep markers are not available in the Modulation Sweep mode.

All of the front panel controls used for the control of modulation sweep are on the left keyboard. Modulation sweep features can also be remotely controlled by the HP-IB (refer to operating instruction entitled "HP-IB Remote Stepped Sweep) or through the auxiliary connector (AUX) on the rear panel. Refer to the operating instruction entitled Modulation Sweep Modes and to paragraph 3-12 AUX connector operation.

The sweep (SWP) output connector on the rear panel provides a 0 to +10 V staircase to drive a swept display.

The **Z-AXIS BLANK/MARKER** connector, on the rear panel, serves as a blanking output (when the Generator is in the Modulation Sweep mode). The Generator outputs a TTL pulse at the beginning of each step in the staircase sweep. This pulse will blank a swept display for a 250 μ s duration.

The **PEN-LIFT** output, located on the rear-panel AUX connector (pin 9), provides a TTL high-level for a pen-up condition and a low-level for pen-down condition. A pen-down condition is produced in the single sweep mode only.

The **SWEEP END** output, located on the rear-panel AUX connector (pin 1), is normally held at a TTL high level. The Sweep End line produces one 5 μ s low-going pulse at the end of each sweep.

When the Modulation Sweep function is disabled (Special Function 40), all Modulation Sweep parameters are reset to their "System Clear" default values.

Detailed Functions

HP-IB Remote Stepped Sweep	Modulation Sweep Span
Modulation Oscillator	Modulation Sweep Time/Step
Modulation Sweep Modes	Modulation Sweep Start-Stop
	Modulation Sweep Step Size

MODULATION SWEEP MODES

Description

This instruction details how to turn the modulation sweep on and off.

The four modulation sweep modes available are: AUTO, MANUAL, SINGLE, and HP-IB controlled REMOTE STEPPED SWEEP (RSS).

Procedure

Verify that the Modulation Sweep function (Special Function 41) has been enabled.

To enable any of the four Modulation Sweep modes, select AUTO, MANUAL, SINGLE, or remotely configure the Generator in REMOTE STEPPED SWEEP (refer to operating instruction entitled "HP-IB Remote Stepped Sweep").

If the MANUAL mode is selected, the sweep may be controlled with the knob.

To turn the modulation sweep off, select MODE OFF.

Keys and Program Codes

Keys	Codes
MODE OFF	W1
AUTO	W2
MANUAL	W3
SINGLE	W4
Knob, CW	RU
Knob, CCW	RD

Indications

When any of one of the three sweep modes (not including RSS) are chosen, the last selected sweep parameters are recalled. The Modulation Sweep parameter-settings are indicated by the appropriate front-panel annunciators: START FREQ-STOP FREQ, SPAN FREQ, STEPS, TIME/STEP and Sweep Mode.

There are no indicators for TIME/STEP in the MANUAL sweep mode since that function is manually controlled.

Sweeping of the modulation frequency is visible on the MOD FREQ readout. The FUNCTION indicator (SWP) will also be lit.

Comments

Automatic Mode starts a continuous sweep, restarting at the end of each sweep.

Selecting the Manual Mode enables the Knob only and does not execute a sweep.

Pressing the MANUAL key will stop a continuous sweep. Pressing AUTO or SINGLE again will restart the sweep (continue where it left off).

Single Sweep mode completes one sweep only. At the end of the sweep, the sweep circuitry is turned off and the modulation frequency reverts to the last selected fixed-frequency.

The AUTO, MANUAL and SINGLE sweep modes can be remotely controlled via the rear-panel AUX connector. To execute a sweep, a TTL negative-true (5 μ s minimum) pulse must be applied to the appropriate pin. AUX connector pin assignments are as follows:

Pin 4—MANUAL sweep mode.

Pin 5—AUTO sweep mode.

Pin 6—SINGLE sweep mode.

Refer to paragraph 3-12 for AUX connector configuration.

When the Modulation Sweep mode is disabled (Special Function 40), all modulation sweep parameters established in the Modulation Sweep mode are reset to their "System Clear" default values.

HP-IB

Remote Stepped Sweep (RSS) is a sweep mode available only in the HP-IB remote mode. It allows the controller to execute each step and still have a SWEEP OUTPUT ramp and a Sweep End pulse at the AUX connector. For more information refer to the detailed operating instruction entitled "HP-IB Remote Stepped Sweep".

Related Functions

HP-IB Remote Stepped Sweep

Modulation Oscillator

Modulation Sweep

Modulation Sweep, Start-Stop

Modulation Sweep, Time/Step

Modulation Sweep, Span

Modulation Sweep, Step Size

MODULATION SWEEP, SPAN

Description

This instruction details how to set modulation frequency sweep limits, above and below the center modulation frequency.

The entered span frequency value represents the total peak to peak deviation from the center frequency.

Modulation Span Width: 0.2 Hz-99.9 kHz. (Refer to Comments.)

Modulation Frequency-Resolution:

Modulation Frequency (f_{mod})	Resolution
$10 \text{ Hz} \leq f_{mod} < 100 \text{ Hz}$	0.1 Hz
$100 \text{ Hz} \leq f_{mod} < 1 \text{ kHz}$	1.0 Hz
$1 \text{ kHz} \leq f_{mod} < 10 \text{ kHz}$	0.01 kHz
$10 \text{ kHz} \leq f_{mod} < 99.9 \text{ kHz}$	0.1 kHz

Procedure

Verify that the Modulation Sweep Mode (Special Function 41) has been enabled. To enter the modulation span frequency, select SPAN FREQ, Data and Units.

Example

Set a modulation span frequency of 100 Hz, $f_c=5 \text{ MHz}$.

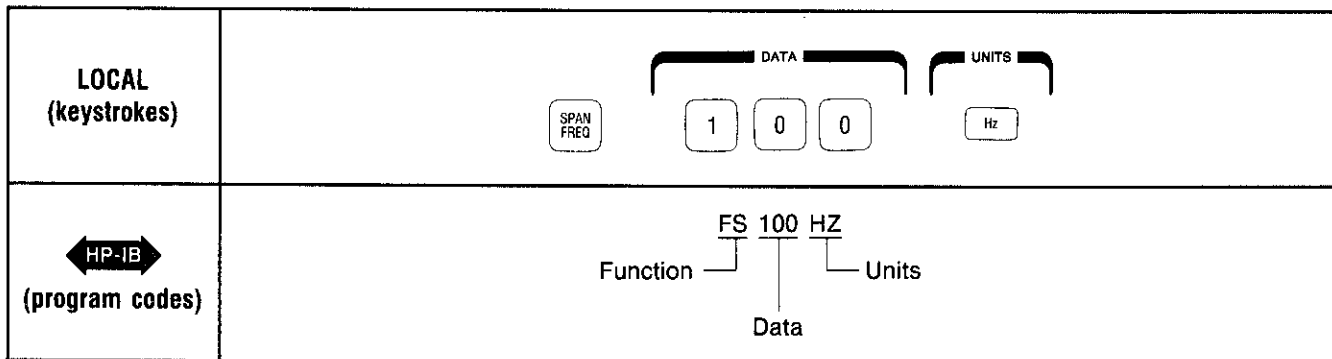

Keys and Program Codes

Keys	Codes
SPAN FREQ	FS
MOD FREQ	MF
kHz	KZ
Hz	Hz

NOTE

Before establishing a modulation span frequency for AM, FM, oM, PULSE, or BPSK, refer to the respective function's Operating Characteristics. The Operating Characteristics describe the instrument's modulation limitations.

Indications

The selected digits should be displayed on the MOD FREQ readout while they are being entered. However, the readout returns to the last selected fixed frequency after the units are selected.

The span frequency may be recalled to the MOD FREQ readout by pressing and holding the SPAN FREQ key.

Selection of the span mode will cause the SPAN FREQ annunciator to turn on.

Comments

The Modulation Span Width is dependent upon the center frequency selected.

Selecting the SPAN FREQ key will turn on the Span function and recall the last selected values for Steps and Time/Step. These parameters are independent from the ones established for the Start-Stop function.

To turn off the SPAN FREQ function off press MODE OFF.

Related Functions

HP-IB Remote Stepped Sweep
Modulation Oscillator
Modulation Sweep
Modulation Sweep Modes
Modulation Sweep, Start-Stop
Modulation Sweep, Step Size
Modulation Sweep, Time/Step

MODULATION SWEEP, START-STOP

Description

This instruction details how to set the starting and stopping point of the modulation frequency sweep.

Modulation Sweep, Start-Stop Range: 10 Hz to 99.9 kHz.

Modulation Frequency-Resolution:

Modulation Frequency (f_{mod})	Resolution
$10 \text{ Hz} \leq f_{mod} < 100 \text{ Hz}$	0.1 Hz
$100 \text{ Hz} \leq f_{mod} < 1 \text{ kHz}$	1.0 Hz
$1 \text{ kHz} \leq f_{mod} < 10 \text{ kHz}$	0.01 kHz
$10 \text{ kHz} \leq f_{mod} < 99.9 \text{ kHz}$	0.1 kHz

Procedure

Verify that the Modulation Sweep Mode (Special Function 41) has been enabled.

To enter the Modulation Sweep start-frequency, select START FREQ, Data, and Units.

To enter the Modulation Sweep stop-frequency, select STOP FREQ, Data and Units.

Example

Set sweep limits at 500 Hz and 5 kHz.

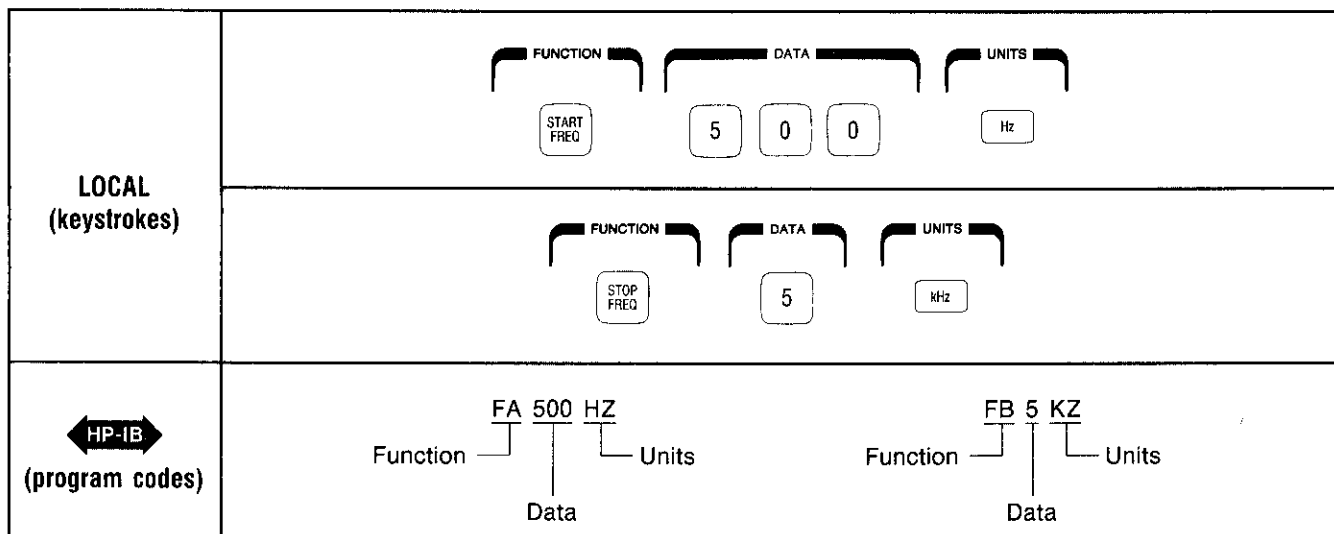

NOTE

Before establishing Start-Stop frequency limits for AM, FM, ϕM , PULSE, or BPSK, refer to the respective function's Operating Characteristics. The Operating Characteristics describe the instrument's modulation limitations.

Keys and Program Codes 

Keys	Codes
START FREQ	FA
STOP FREQ	FB
KHz	KZ
Hz	HZ

Indications

The selected digits will be displayed on the MOD FREQ readout while they are being selected. However, the readout will return to the last selected fixed frequency after the units are selected.

The start or stop frequency can be recalled to the MOD FREQ readout by pressing and holding the START FREQ or STOP FREQ key.

Selection of the Start-Stop mode will cause the Start-Stop annunciator to turn on.

Comments

The start frequency may be set higher than the stop frequency causing the sweep to progress from high to low. Selecting the Start or Stop keys will recall the last "Start-Stop" combination of Steps and Time/Step.

The Steps and Time/Step sweep parameters for the Start-Stop function are independent of the parameters established for the Span operation.

To turn the Start-Stop function off, select MODE OFF.

Related Functions

HP-IB Remote Stepped Sweep
 Modulation Oscillator
 Modulation Sweep
 Modulation Sweep Modes
 Modulation Sweep, Span
 Modulation Sweep, Step Size
 Modulation Sweep, Time/Step

MODULATION SWEEP, STEP SIZE

Description

This instruction details how to select log or linear sweeps, as well as the step size for each of the modulation frequency sweep modes.

LIN 100 and LIN 1000 set the increment to a constant value equal to sweepwidth/100 or sweepwidth/1000, respectively.

LOG 10% and LOG 1% set the initial step size equal to 10% or 1% of the present frequency, depending on the key selected. All subsequent step sizes are then increased by the selected percentage.

SET SIZE is used to set the frequency increment to a constant value (settable within the modulation frequency-range and resolution of the Generator).

Modulation Frequency-Resolution:

Modulation Frequency (f_{mod})	Resolution
$10 \text{ Hz} \leq f_{mod} < 100 \text{ Hz}$	0.1 Hz
$100 \text{ Hz} \leq f_{mod} < 1 \text{ kHz}$	1.0 Hz
$1 \text{ kHz} \leq f_{mod} < 10 \text{ kHz}$	0.01 kHz
$10 \text{ kHz} \leq f_{mod} < 99.9 \text{ kHz}$	0.1 kHz

Procedure

Verify that the Modulation Sweep function (Special Function 41) has been enabled.

To enter a step size, select one of the four preset step-size keys or select SET SIZE, Data and Units.

Example

Set modulation frequency step size to 1.0 kHz.

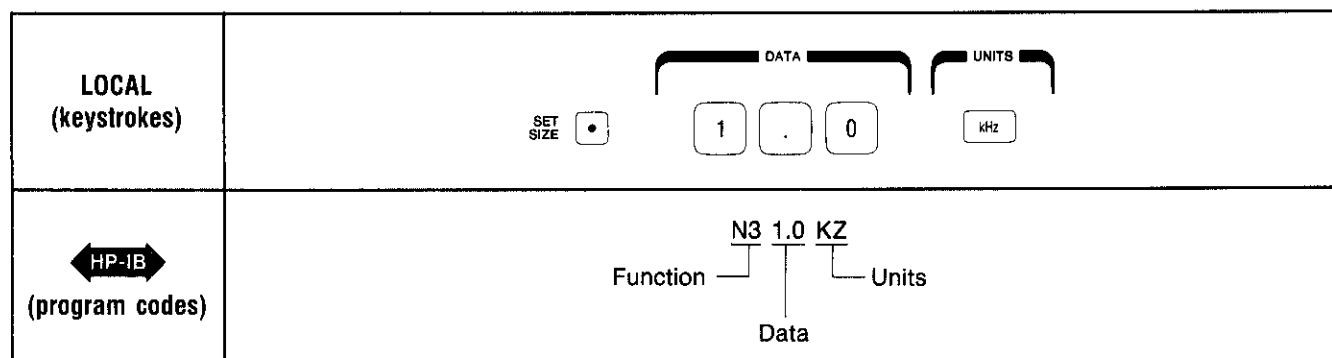

Keys and Program Codes

Keys	Codes
LIN 100	N1
LIN 1000	N2
SET SIZE	N3
LOG 10%	N4
LOG 1%	N5
kHz	KZ
Hz	HZ

Indications

If one of the four preset increments is selected, the only indication will be the light in the selected key turning on.

If SET SIZE is selected, the light in the key will turn on. The selected digits will be displayed on the MOD FREQ readout while they are being entered. However, the readout will return to the last-selected fixed frequency after the units are selected.

Step size can be recalled to the frequency readout by pressing and holding the SET SIZE key.

Comments

In the manual sweep mode, turning the knob counterclockwise with LOG 10% selected, will produce a frequency value determined by $(\text{present frequency}/1.10)$. Selection of LOG 1% produces a frequency value determined by $(\text{present frequency}/1.01)$.

For more information regarding the knob function, refer to the detailed operating instruction entitled "Knob".

In the modulation sweep Start-Stop mode, the stop frequency is the point at which the Generator can no longer execute a full sweep-step. Therefore, the entered stop frequency value may be different from the actual stop frequency.

Related Functions

Knob
Modulation Oscillator
Modulation Sweep
Modulation Sweep Markers
Modulation Sweep Modes
Modulation Sweep, Span
Modulation Sweep, Start-Stop
Modulation Sweep, Time/Step

MODULATION SWEEP, TIME/STEP

Description

This instruction details how to set the interval between steps of the staircase modulation sweep.

Procedure

Verify that the Modulation Sweep mode (Special Function 41) has been enabled.

To enter the Time/Step interval, select one of the following preset values: 2, 10, or 100 ms.

Keys and Program Codes

Keys	Codes
2 ms	T3
10 ms	T4
100 ms	T5

Indications

The only indications will be the light in the selected key turning on.

Comments

The 0.5 ms and 1 ms Time/Step keys are disabled in the Modulation Sweep mode.

Related Functions

Modulation Oscillator
Modulation Sweep
Modulation Sweep Modes
Modulation Sweep Span
Modulation Sweep, Start-Stop
Modulation Sweep, Step Size

RF SWEEP

Description

This instruction provides information detailing the RF Output Frequency Sweep mode of the Generator.

The instrument's RF frequency changes in discrete steps rather than in a continuous analog manner.

The Generator can sweep from 1.0 kHz to 2560 MHz. The minimum step size is 0.1 Hz for signals below 640 MHz, 0.2 Hz from 640 MHz to 1280 MHz, and 0.4 Hz from 1280 MHz and above.

The sweep can be either linear or logarithmic. There are five selectable values of time per step: 0.5 ms (nominal), 1, 2, 10, and 100 ms.

Five frequency markers can be set. The markers can be either Z-axis intensity modulated on a swept display or amplitude modulated on the RF signal (or both).

Modes

Four sweep modes are available. They are: Automatic, Manual, Single and HP-IB Remote Stepped Sweep. Each mode enables the sweep parameters that were previously selected (parameters are common to all sweep modes).

Amplitude Correction

The correction feature is automatically disabled in all RF sweep modes, however, it can be enabled during sweep with Special Function 87. Refer to the detailed operating instruction entitled, "Amplitude Correction, RF Sweep Mode".

Sweep Parameters

The following sweep parameters are value-selectable:

Start-Stop frequencies	Time/Step
Center Frequency and Span	Marker frequencies
Sweep step size (\times F/step)	

RF Sweep Controls

All the front panel controls that are exclusively for sweep are on the left keyboard. Sweep features can also be remotely controlled by the HP-IB or through the auxiliary (AUX) connector on the rear panel when configured in the Mode 1 operation. Refer to paragraph 3-12 for the description of the AUX connector or the operating instruction entitled "HP-IB Remote Stepped Sweep".

Inputs and Outputs

The **SWP** output connector on the rear panel provides a 0-+10V staircase to drive a swept display (maximum of 10,000 steps).

The **AM MKR** connector on the rear panel outputs 5 kHz triangle-wave bursts. This output can be connected to the front-panel modulation input (AM IN), to produce adjustable AM markers on the RF signal.

The rear-panel **Z-AXIS BLANK/MARKER** connector serves the dual purpose of blanking and/or intensifying a swept display (Z-axis intensity modulation).

A blanking pulse (TTL high-level) is produced at the beginning of each step of the staircase sweep. This pulse will blank a swept display for a 250 μ s duration and will prevent a CRT from responding to switching transients developed by the Generator.

A marker pulse (-5V pulse) is produced at the point of a selected marker frequency (-5V is nominal; it is internally adjustable between -2 and -8V).

The **PEN LIFT** output, located on the rear-panel AUX connector (pin 9), provides a TTL high-level for a pen-up condition and a low-level for a pen-down condition. A pen-down condition is produced in the single sweep mode only.

The **AUX** connector contains three sweep control-lines; each control one of three sweep modes (AUTO, MANUAL, and SINGLE). These input lines are TTL negative-edge sensitive.

The **SWEEP END** output, located on the rear-panel AUX connector (pin 1), is normally held at a TTL high level. The Sweep End line produces one 5 us low-going pulse at the end of each sweep.

Detailed Functions

Most of these sweep characteristics are covered in greater detail in separate instructions:

HP-IB Remote Stepped Sweep	RF Sweep, Span
RF Sweep Markers	RF Sweep Start-Stop
RF Sweep Modes	RF Sweep Step Size
	RF Sweep Time/Step

RF SWEEP MODES

Description

This instruction details how to turn the RF sweep on or off.

The four sweep modes available are: AUTO, MANUAL, SINGLE, or HP-IB REMOTE STEPPED SWEEP.

Procedure

To enable any of the four Sweep modes, select the AUTO, MANUAL or SINGLE keys or remotely configure the Generator in REMOTE STEPPED SWEEP (refer to the operating instruction entitled "HP-IB Remote Stepped Sweep").

If the MANUAL mode is selected, control the sweep with the knob.

To turn the sweep off, select MODE OFF.

Keys and Program Codes

Keys	Codes
MODE OFF	W1
AUTO	W2
MANUAL	W3
SINGLE	W4
Knob, CW	RU
Knob, CCW	RD

Indications

In AUTO and SINGLE sweep modes, there will be a split frequency readout: START-STOP, or CF (center frequency)- ΔF (span frequency). Each readout contains five digits. Digits representing greater than five-digit resolution are not displayed. If 10 ms or 100 ms per step is selected, the left readout will display the changing frequency as it sweeps.

In MANUAL mode, there is only one display of output frequency which changes as the frequency is swept using the knob.

When any of the sweep modes are selected, the sweep parameters last selected are turned on; as indicated by each of the function's annunciators (START FREQ-STOP FREQ, SPAN FREQ, STEP SIZE, TIME/STEP, and MODE). There are no lights for TIME/STEP in the MANUAL mode since that function is manually controlled.

Comments

Automatic Mode starts a continuous sweep, restarting at the end of each sweep.

Selecting the Manual Mode enables the Knob only and does not execute a sweep.

Selecting the MANUAL key will stop a continuous sweep. Selecting AUTO or SINGLE again will restart the sweep (continue where it left off).

Single Sweep Mode completes one sweep only. At the end of the sweep, the sweep circuitry is turned off and the RF frequency reverts to the last selected fixed-frequency.

The AUTO, MANUAL and SINGLE sweep modes can be remotely controlled via the rear-panel AUX connector. To execute a sweep, a TTL negative-true (5 μ s minimum) pulse must be applied to the appropriate pin. Refer to paragraph 3-12 for more information regarding the AUX connector configuration. AUX connector pin assignments are as follows:

Pin 4—MANUAL sweep mode.

Pin 5—AUTO sweep mode.

Pin 6—SINGLE sweep mode.



In remote HP-IB control, the knob requires one program code (either RU or RD) to perform a Manual sweep step.

Remote Stepped Sweep (RSS). RSS is a sweep mode available only in the HP-IB remote mode. It allows the controller to execute each step and still have a SWEEP OUTPUT ramp and a Sweep End pulse at the AUX connector. For detailed information refer to the operating instruction entitled "HP-IB Remote Stepped Sweep".

Related Functions

HP-IB Remote Stepped Sweep

Knob

Sweep Markers

Sweep, Span

Sweep, Start-Stop

Sweep Step Size

Sweep Time/Step

RF SWEEP MARKERS

Description

This instruction details how to turn on the Generator's Markers more specifically, how to set or change the marker frequencies.

Five different marker frequencies can be set.

The Generator can produce Z-axis intensity markers for a swept display or amplitude markers on the RF signal.

The Z-axis intensity markers are nominally -5V. However, they are internally adjustable between -2 and -8V (Refer to Section V, Adjustments). Z-axis markers are available through the rear panel Z-AXIS BLKG/MKR connector.

The amplitude markers are 5 kHz triangle-wave bursts available at the rear panel AM MKR output. This output can be connected to the front-panel MODULATION INPUT to produce adjustable AM markers on the RF signal. Refer to the operating instruction entitled Modulation, External AM.

Procedure

To set a marker frequency: Select a MARKERS key, Data and Units.

To turn a marker on, select the appropriate MARKERS key. The marker will turn on only if it is within the current sweepwidth.

To turn a selected marker off, select the appropriate MARKERS key and OFF.

To turn all markers off, select Blue Key and ALL OFF.

Example

Set Marker 2 to 700 MHz.

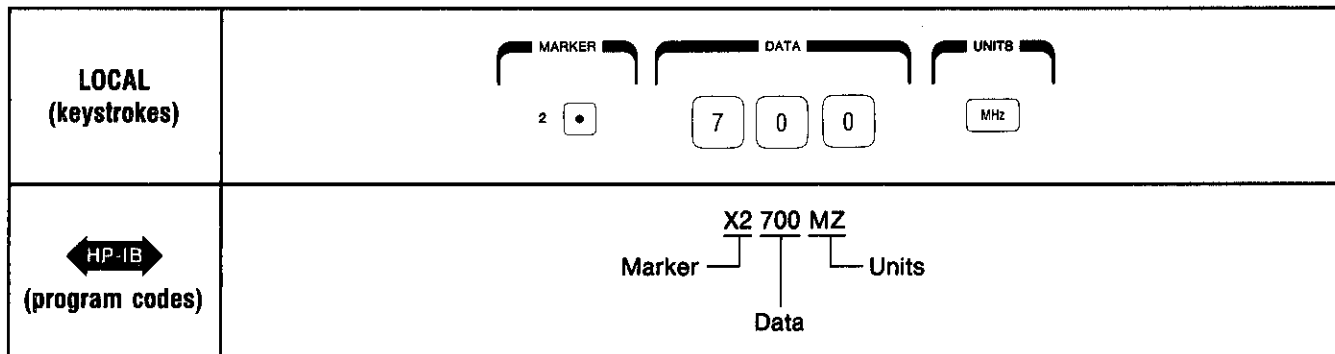

Keys and Program Codes

Keys	Codes
MARKERS	
1	X1
2	X2
3	X3
4	X4
5	X5
OFF	X6
Blue Key	BL
ALL OFF	X7

NOTE

The ALL OFF feature can be programmed with a simple X7 or with BL and X6 (Blue Key and OFF).

Indications

Lights in the MARKERS keys turn on only when the marker is on.

When a marker key is pressed and held, the frequency assigned to that marker appears in the FREQUENCY readout and the output signal changes to that marker frequency.

Comments

Marker frequencies cannot be stored in individual storage registers. They are global parameters; that is, once established, they apply to any set of parameters recalled from storage. A Marker's "on" or "off" status, however, can be stored in a register.

Marker frequency values can be changed by the INCREMENT $\uparrow \downarrow$ keys or with the Knob function.

Markers are not available in any of the Modulation Sweep modes.

Related Functions

Frequency Copying

Increment $\uparrow \downarrow$

Knob

RF Sweep

RF SWEEP, SPAN

Description

This instruction details how to set RF frequency sweep limits above and below a specified RF center frequency.

The entered span frequency value represents the total peak to peak deviation above and below the center frequency.

Span Width: .2 Hz to 2560 MHz (2559. 999 999 6), (refer to Comments).

Procedure

To enter a span center frequency, select FREQUENCY, Data, and Units.

To enter span, select SPAN FREQ, Data, and Units.

Example

Select 700 MHz center frequency and a 100 MHz span.

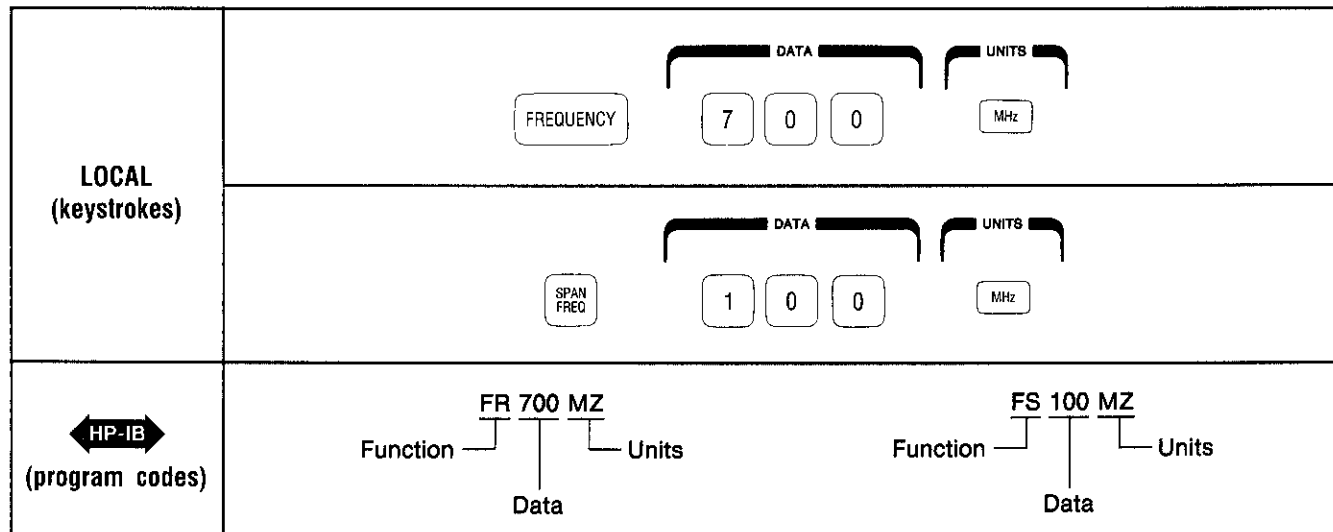

Keys and Program Codes ↔ HP-IB ↔

Keys	Codes
FREQUENCY	FR
SPAN FREQ	FS
GHz	GZ
MHz	MZ
kHz	KZ
Hz	HZ

Indications

After the frequency span has been selected, the readout will revert to the center frequency.

The frequency span can be recalled to the readout by holding down the SPAN FREQ key. In this situation, the ΔF frequency annunciator will also turn on.

Comments

The Span Width is dependent upon the center frequency selected.

Selecting the SPAN FREQ key also recalls the last "span" combination of Steps and Time/Step. (The values of Steps and Time/Step for the SPAN function are independent from the values established for the Start-Stop function.)

The lower sweep limit of the Generator can extend down to 1.0 kHz, however, the instrument's operational characteristics are not specified below 100 kHz.

Digits representing less than tenth-hertz resolution are truncated.

Digits not selected default to zero.

During sweep, the Knob, numeric keypad or INCREMENT $\uparrow \downarrow$ functions can be used to change the center frequency or delta frequency. Selecting the SPAN FREQ key and entering new value will interrupt the frequency excursion and cause the sweep to begin at the new lower frequency limit. If a new value is entered for the center frequency, the sweep will be interrupted for the duration of the entry before resuming from the new, lower frequency limit.

Related Functions

HP-IB Remote Stepped Sweep
RF Sweep
RF Sweep Markers
RF Sweep, Start-Stop
RF Sweep, Step Size
RF Sweep, Time/Step

RF SWEEP, START-STOP

Description

This instruction details how to set upper and lower limits for the RF frequency sweep.

The values for START and STOP represent the frequencies where the sweep will begin and end, respectively.

Sweep width: 100 kHz to 2560 MHz, (2559. 999 999 6).

Procedure

To enter the Start frequency, select START FREQ, Data, and Units.

To enter the Stop frequency, select STOP FREQ, Data, and Units.

Example

Set sweep limits at 600 and 800 MHz.

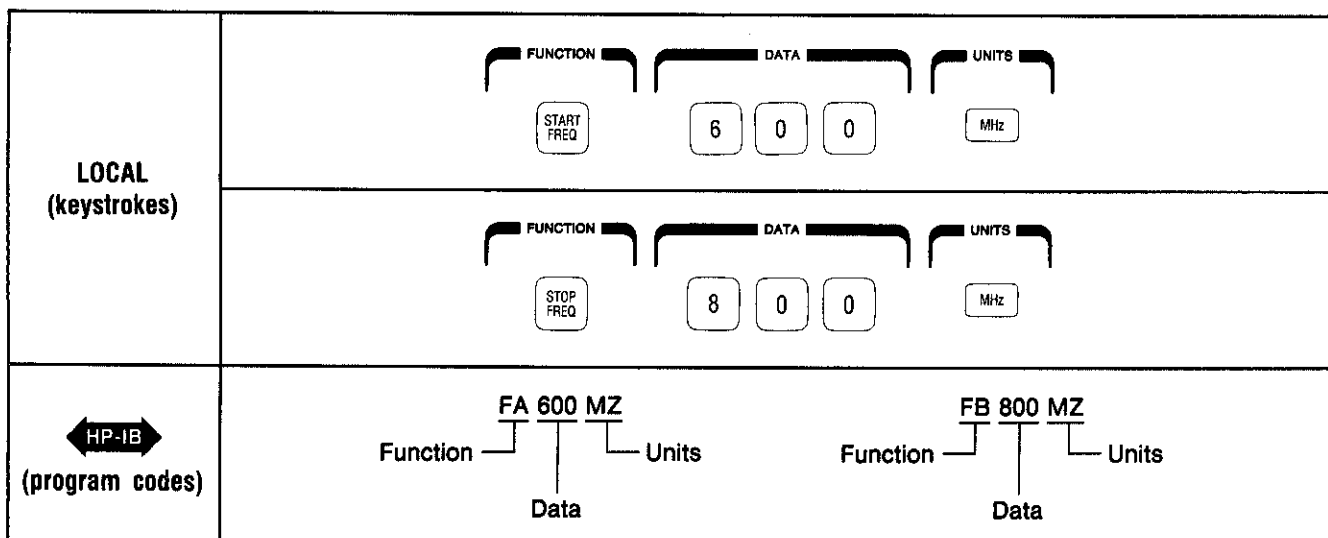

Keys and Program Codes

Keys	Codes
START FREQ	FA
STOP FREQ	FB
GHz	GZ
MHz	MZ
kHz	KZ
Hz	HZ

Indications

The selected digits will be displayed in the FREQUENCY readout while they are being selected. However, the readout returns to the last-selected fixed frequency after the units are selected.

The start or stop frequency can be recalled to the readout by holding down the START FREQ or STOP FREQ key (both local and remote operation). In this situation, the START or STOP frequency annunciator should also turn on.

During sweep, the FREQUENCY readout will have a split display with the Start frequency on the left and the Stop frequency on the right.

Comments

The lower sweep limit of the Generator can be extended down to 1 kHz, however, RF level accuracy is unspecified below 100 kHz.

The start frequency can be higher than the stop frequency causing the sweep to progress from high to low.

Selecting the Start or Stop keys will recall the last selected "Start-Stop" values of Steps and Time/Step.

The Steps and Time/Step sweep parameters selected for the Start-Stop function are independent of the parameters established for the Span sweep operation.

To turn the Start-Stop function off, select MODE OFF.

Digits representing less than tenth-hertz resolution are truncated.

During sweep, the Knob, numeric keypad or INCREMENT $\uparrow \downarrow$ functions can be used to change the upper and lower sweep limits. Selecting the START FREQ key and entering new value will interrupt the frequency excursion and cause the sweep to begin at the new frequency. If a new value is entered for the stop frequency, the sweep will be interrupted for the duration of the entry before resuming to the new stop value.

Digits not selected default to zero.

Related Functions

- RF Sweep
- RF Sweep Markers
- RF Sweep Modes
- RF Sweep, Span
- RF Sweep Step Size
- RF Sweep Time/Step

RF SWEEP, TIME/STEP

Description

This instruction details how to set the interval between steps of the RF sweep.

Procedure

To enter the Time/Step interval, select one of the following preset values: 0.5 ms nominal (1, 2, 10, or 100 ms (see Comments)).

Keys and Program Codes

Keys	Codes
0.5 ms	T1
1 ms	T2
2 ms	T3
10 ms	T4
100 ms	T5

Indications

The only indication will be the light in the selected key turning on.

Comments

The shortest interval between steps is approximately 0.5 ms for a simple linear sweep. This time would be longer for log sweeps, markers, and FM, ϕ M, BPSK (0.9 ms maximum). If amplitude correction is enabled during sweep (Special Function 87), the minimum accurate sweep time is 10 ms.

Related Functions

- RF Sweep
- RF Sweep Markers
- RF Sweep Modes
- RF Sweep Span
- RF Sweep, Start-Stop
- RF Sweep Step Size

RF SWEEP, STEP SIZE

Description

This feature details how to select log or linear sweeps as well as the step size for each step of the RF sweep.

LIN 100 and LIN 1000 set the step size to a constant value equal to sweepwidth/100 or sweepwidth/1000, respectively.

LOG 10% and LOG 1% set the initial step size value equal to 10% or 1% of the start frequency; all subsequent step sizes are increased 10% or 1%, respectively.

SET SIZE is used to set the frequency increment to a constant value of your choice (settable within the resolution and frequency range of the Generator).

Resolution: 0.1 Hz (below 640 MHz).
 0.2 Hz (above 640 MHz and below 1280 MHz).
 0.4 Hz (above 1280 MHz).

Procedure

To enter the step size, select one of the four preset step size keys or select SET SIZE, Data and Units.

Example

Set frequency step size to 100 kHz.

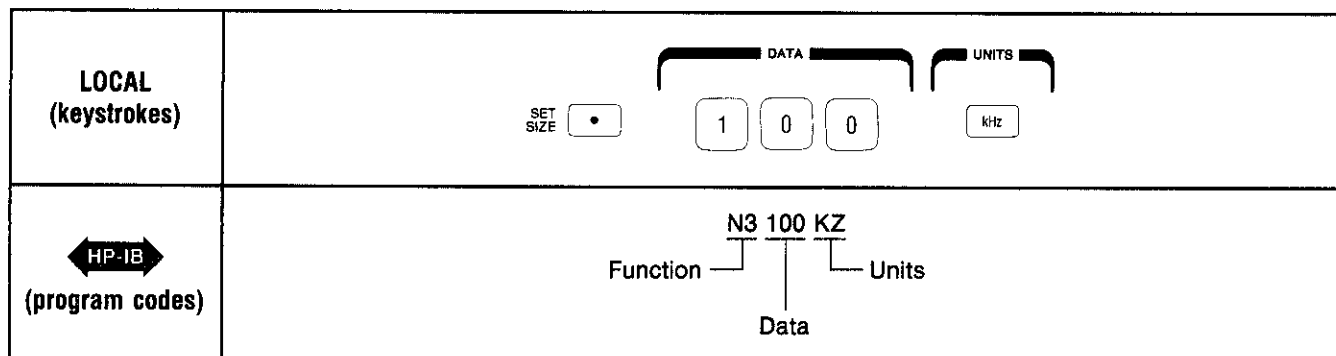

Keys and Program Codes

Keys	Codes
LIN 100	N1
LIN 1000	N2
SET SIZE	N3
LOG 10%	N4
LOG 1%	N5
GHz	GHZ
MHz	MZ
kHz	KZ
Hz	HZ

Indications

If one of the four preset increments is selected, the only indication will be the light in the selected key turning on.

If the SET SIZE key is selected, the light in the key will turn on. Step size will be displayed on the FREQUENCY readout as the digits are being entered, however, the readout will return to the last-selected fixed frequency after the units are selected.

Step size can be recalled to the frequency readout by pressing and holding the SET SIZE key.

Comments

In the manual mode, turning the knob counterclockwise with LOG 10% or 1% selected, causes the Generator to step to a frequency equal to present frequency/1.10 or present frequency/1.01, respectively. Clockwise rotation will cause the Generator to step to a frequency equal to the present frequency*1.10 or present frequency*1.01 if the LOG 10% or 1% keys (respectively) are selected.

The actual stop frequency is defined as the point at which the Generator can no longer perform a complete step; the Generator cannot execute a partial step and may, therefore, never reach the entered stop frequency.

For more information regarding the knob function, refer to the detailed operation entitled "Knob".

Related Functions

- HP-IB Remote Stepped Sweep
- RF Sweep
- RF Sweep Markers
- RF Sweep Modes
- RF Sweep, Span
- RF Sweep, Start-Stop
- RF Sweep Time/Step

MEMORY CHECK (Special Functions 83 and 84)

Description

This instruction details how to verify the integrity of the Generator's RAM (that is, temporary memory) and ROM (that is, permanent memory).

NOTE

These checks are essentially the same as the Turn-on Memory Check. Therefore, they do not have to be repeated at each turn-on. They should only be performed if a fault is suspected.

Special Functions 83 and 84 are identical to the Turn-on Memory Check, however, the Generator's indications (during the check) and response to faults are different. They check for faulty ROM or RAM, or for altered data in RAM. These are only quick checks which are not as comprehensive as the diagnostics described in Section VIII, Service.

Procedure

To perform the ROM check, press the Blue Key, SPECIAL and 83.

To perform the RAM check, press the Blue Key, SPECIAL and 84.

Indications

During the check, and until a fault is detected, the FREQUENCY readout will display 00. If a fault is detected, two things will occur:

- Two-digit numeric codes will replace the 00 (these codes are additional diagnostic aids and are described in the Digital Control Unit (DCU) diagnostic troubleshooting found on BD9 in Section VIII, Service).
- The STATUS key light will turn on blinking (hardware malfunction code 99 will be set in STATUS block of the FREQUENCY readout).

At the end of the test, the readout will revert to its original display.

Comments

If fault is detected in a ROM check, the Generator might be useable but it does require servicing.

If a fault is detected in a RAM check, it could be a result of a single bit of data being changed due to line transients, noise, or other unpredictable conditions. The Generator might be useable and may not need to be serviced unless the fault occurs repeatedly.

SEQUENCE (Includes Special Function 88)

Description

This instruction details how to define and execute a recall-order of the Generator's front-panel storage register contents.

The sequence (SEQ) key recalls the register contents in the predetermined sequence, one register per keystroke of the SEQ key.

The Auto-Sequence feature executes a continuous recall of the register contents according to the predetermined sequence.

Procedure

To set the sequence (that is, recall-order), select the Blue Key, SET SEQ, Data (register numbers in the desired recall order), and STORE.

To view the recall-order, select RECALL then press and hold the sequence SEQ key.

To recall register contents, according to the predetermined sequence, select the SEQ key, once for each register.

To initiate a continuous recall of registers in the predetermined sequence, select Blue Key and AUTO SEQ.

To stop an Auto Sequence operation, select any key except STATUS.

Example

Set the register recall sequence to 1, 2, 7, 2, and 5.

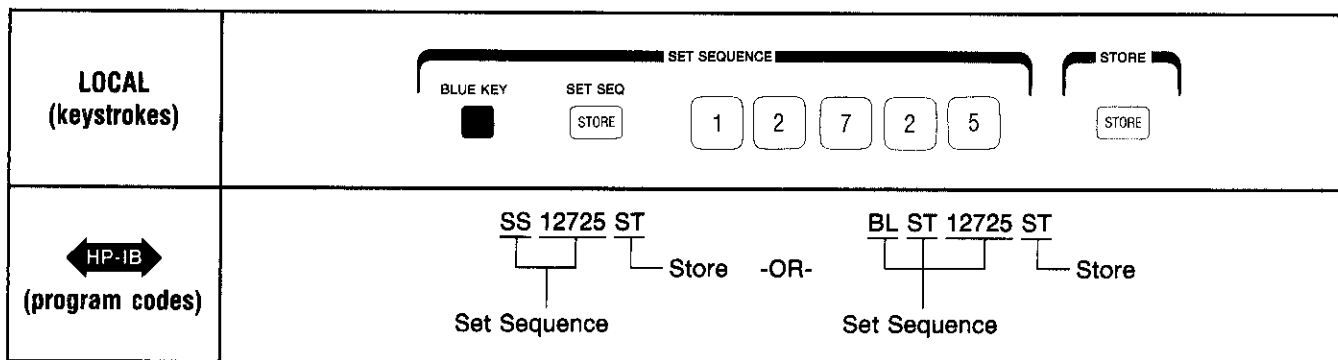

Keys and Program Codes

Keys	Codes
Blue Key	BL
SET SEQ	SS
AUTO SEQ	AS
STORE	ST
SEQ	SQ

NOTE

SET SEQ can be programmed with a simple SS (or with BL and ST). AUTO SEQ can be programmed with a simple AS (or with BL and SQ).

Indications

The programmed recall order will be displayed on the FREQUENCY readout after the RECALL key is selected and then the SEQ key is pressed and held down. The blinking digit indicates the last-recalled register (or the first register in the sequence if no recall has been made yet).

The digit to the right of the blinking digit always represents the next register to be recalled (this includes wrap-around to the first digit).

Comments

The operator should consider switching to the uncorrected Amplitude mode (Special Function 85) when using the auto sequence capability. This not only increases auto sequence speed, but also prevents excessive mechanical wear of the attenuator. Refer to the "AMPLITUDE CORRECTION" operating instruction regarding Special Function 85.

Any register selection sequence is allowable. The maximum number of digits in a sequence is ten. Register numbers can be repeated in a sequence string (for Example, 3-6-4-5-7-7-5-4-6-3).

In the Auto Sequence mode, the Generator recalls the selected registers in rapid succession (1 ms nominal delay between steps). The time period between steps of the Auto Sequence function can be varied from 1 ms to 5s (refer to the instruction entitled "Sequence, Step-Delay").

If an AUTO-SWEEP mode is encountered, the Generator performs a single sweep, then recalls the next register; if a MANUAL-SWEEP mode is encountered, the sequencing will stop. The Generator, however, will be configured for Manual Sweep mode.

Selecting any key, except STATUS, will stop Auto-Sequencing. When a key is selected, the Generator will perform the assigned key function.

Special Function 88 will be displayed in the Special Functions block of the FREQUENCY display if the Auto Sequence mode is enabled.

Related Functions

Store-Recall
Sequence, Step-Delay

SEQUENCE, STEP-DELAY (Special Function 90)

Description

This instruction details how to select the time period between steps of the Auto Sequence function.
Step Delay Range: 28 ms to 5.028s.

Procedure

To enter the Sequence step-delay value, select Blue Key, SPECIAL and 90.
Enter the value of step-delay to be added to the minimum step-delay of 27 milliseconds. The data which specifies this time period must be entered with a four-digit format, units of milliseconds implied i.e. 0001-5000 (ms).

Example

Select a sequence, step-delay of 1.028 seconds.

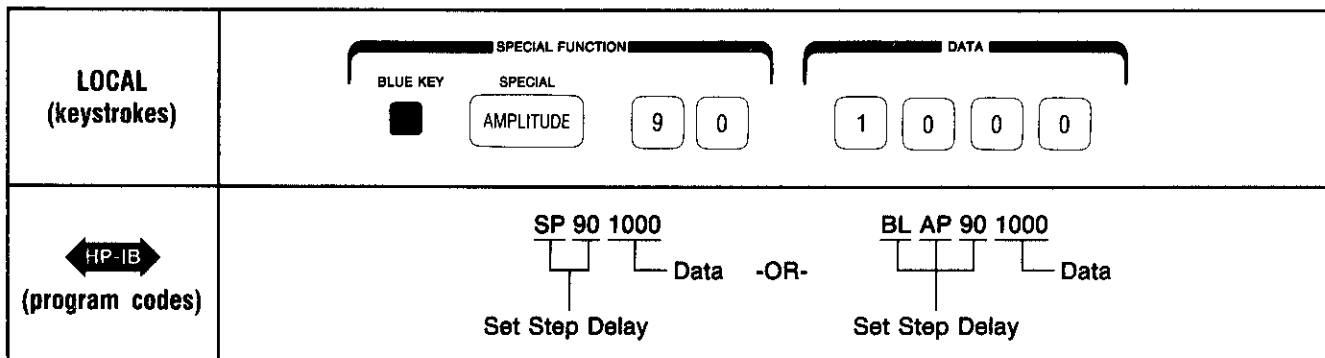

Keys and Program Code

All of the keys and codes used in the Sequence, Step- Delay feature are shown in the example. Note: the SPECIAL function can be programmed with a simple SP or BL and AP (Blue Key and Amplitude).

Indications

- When Special Function 90 is invoked, the FREQUENCY display will blank.
- When the fourth digit of the step-delay value is entered, the FREQUENCY display will return to the last selected RF frequency setting.
- When the STATUS key is pressed and held, the step-delay value will appear in the Sequence Step-Delay block of the FREQUENCY readout, leading zeros blanked. Special function 90 is used to enter data only and will therefore not be displayed in the Special Functions block.

FREQUENCY

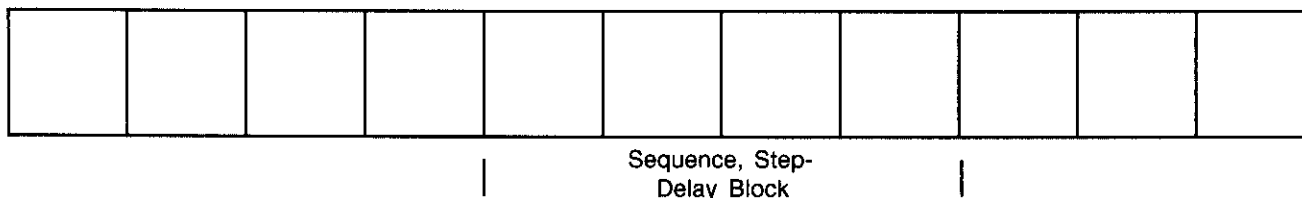

When the Generator performs the Auto Sequence operation, the AMPTD annunciator will flash prior to the execution of each step.

Comments

None.

Related Functions

Sequence
Store-Recall

SPECIAL FUNCTIONS

Description

This instruction details how to implement any of the Generator's Special Function modes. Abbreviated descriptions of the Special Function codes are listed in Table 3-7 and 3-8. Detailed information regarding each Special Function is covered under the related operating instruction (when applicable to the particular instruction).

Procedure

To enter a Special Function, select Blue Key, SPECIAL and the two-digit code.

Example

Initialize the front panel (Special Function 00).

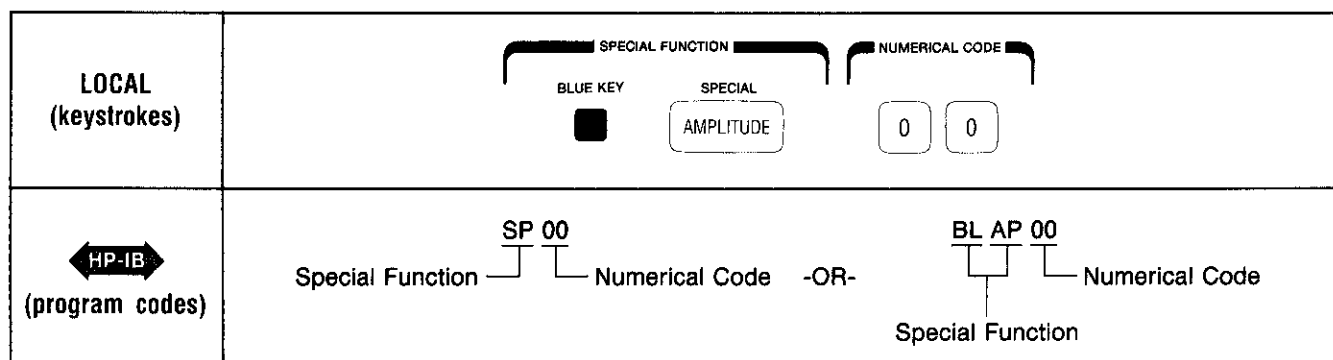

Keys and Program Codes

All of the keys and codes used in the Special Function feature are shown in the examples. Note: the SPECIAL function can be programmed with a simple SP or BL and AP (Blue Key and AMPLITUDE).

Indications

Many of the Special Function codes will be displayed in the Special Functions Block of the Frequency readout when the STATUS key is pressed (in the second and third digits from the left).

FREQUENCY

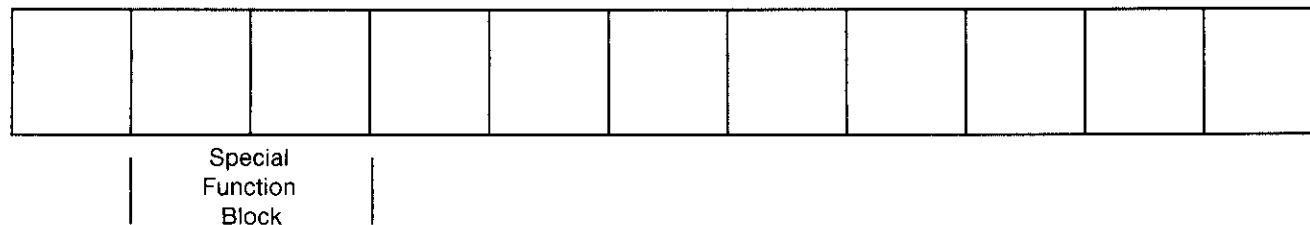

The following codes are not displayed:

1. All codes ending in zero.
2. Codes starting with eight except 85, 87 and 88.
3. Codes 92, 96 and 98.

Comments

Special Functions (with the exception of Special Function 41) cannot be stored in individual storage registers and are considered global parameters; that is, once enabled, the special function applies to any set of parameters recalled from storage.

ROM and RAM checks (83 and 84) are described in this section under paragraph 3-8 "Turn-on Memory Check" and in the detailed operating instruction entitled "Memory Check".

HP-IB

HP-IB Operator Response (89) issues a Request Service Message. For more information, refer to the operating instruction entitled "HP-IB Request Service (RQS) Message".

Automatic Sequence (Special Function 88 is identical to the AUTO SEQ keystroke function.

Related Functions

Amplitude, Manual Level-Control
Amplitude Conversion (V → dBm)
Amplitude Correction
Amplitude Reference
Frequency Hopping
Frequency Offset
HP-IB Address Display
HP-IB Request Service Message
Increment ↑ ↓
Increment, Parameter Shift Keying
Knob, Increment/Revolution
Modulation, Mixed
Modulation, PM
Modulation Sweep
Sequence
Sequence, Step-Delay

Table 3-7. SPECIAL FUNCTIONS (Alphabetical Order)

Operating Instruction	Description	Code
ALC Bandwidth Reduction	Reduces ALC bandwidth < 1 kHz.	21
	Restores bandwidth to > 100 kHz.	20
Amplitude Conversion	Converts displayed amplitude in units of volts to units of dBm.	81
Amplitude Correction	Disables Auto. Level Correction Function.	85
	Enables Auto. Level Correction Function.	86
Amplitude Correction, Sweep Mode	Enables Auto. Level Correction function, sweep mode inclusive.	87
Amplitude, Manual Level-Control	Allows user to define settings for Vernier and Attenuator.	93
Amplitude Reference	Converts displayed RF amplitude to a reference of 0.0 dB.	31
	Restores RF amplitude to units of dBm.	30
Amplitude, μ V Reference	Converts RF amplitude to a relative value, referenced to 1 μ V.	32
	Restores RF amplitude to units of dBm.	30
Frequency Hopping	Enables the Generators rapid switching mode.	91
Frequency Offset	Sets RF frequency at a positive offset from displayed frequency.	11
	Sets RF frequency at a negative offset from displayed frequency.	12
	Removes any RF frequency offset.	10
HP-IB Address Display	Recalls and displays Generator's HP-IB address.	82
HP-IB Service Request	Operator initiated Service Request.	89
Knob, Increment/Revolution	Changes Knob Incr/Rev setting from 12 Incr/Rev to 120 Incr/Rev	94
	Changes Knob Incr/Rev setting from 12 Incr/Rev to 120 Incr/Rev and reconfigures AUX connector.	95
	Restores Knob to 12 Incr/Rev and disables AUX connector Knob function.	92
Modulation, Ext AUX FM	Enables rear-panel AUX FM input connector.	51
	Disables rear-panel AUX FM input connector.	50
Modulation, Ext. Phase Mod. Input Impedance	External PM inputs impedance equal to 600 ohms.	71
	External PM input impedance equal to 50 ohms.	70
Modulation Oscillator	Turns modulation oscillator off if all internal modulation functions are off.	96
	Turns modulation oscillator on.	97
Modulation Sweep	Enables Modulation Sweep Mode.	41
	Disables Modulation Sweep Mode.	40
Numeric Displays	Turns off FREQ., MOD. and AMPTD. readouts and annunciators.	99
	Readouts and annunciators, on.	98
Parameter Shift Keying	Enables the Increment UP DN keys in the P.S.K. Increment Mode.	61
	Enables the Increment UP DN keys in the P.S.K. Toggle Mode.	62
	Disables the P.S.K. Mode.	60
RAM Test	Verifies RAM integrity. Refer to Section III, Memory Check.	84
ROM Test	Verifies ROM integrity. Refer to Section III, Memory Check.	83
Sequence	Identical to the front-panel AUTO SEQ key.	88
	Allows entry of time period between Auto Sequence steps.	90
Special Functions Off	Turns Special Functions 10, 20, 30, 40, 50, 60, and 70 off.	80
System Clear	Initialize front panel.	00
	Executes System Clear and clears Storage Registers 1-9 at power-up.	2.1
	Disables power-up system clear.	2.0

Table 3-8. SPECIAL FUNCTION CODES (Numerical Order)

Code	Special Function Description
00	System clear. Initializes instrument's front panel.
10	Frequency offset off.
11	Sets positive frequency offset.
12	Sets negative frequency offset.
20	Restores ALC bandwidth to > 100 kHz.
21	Reduces ALC bandwidth to < 1 kHz.
30	Amplitude reference off.
31	Converts displayed RF amplitude to a reference of 0.0 dB.
32	Converts RF amplitude to a relative value referenced to 1 μ V.
40	Modulation frequency sweep mode—off.
41	Modulation frequency sweep mode—on.
50	Rear-panel AUX FM connector—off.
51	Rear-panel AUX FM connector—on.
60	Parameter shift keying mode—off.
61	Parameter shift keying increment mode—on.
62	Parameter shift keying toggle mode—on.
70	External PM input impedance equal to 50 ohms.
71	External PM input impedance equal to 600 ohms.
80	Special functions 10, 20, 30, 40, 50, 60, 70 off.
81	Volts to dBm conversion.
82	HP-IB address display.
83	ROM test.
84	RAM test.
85	Amplitude correction—off.
86	Amplitude correction—on.
87	Amplitude correction (including sweep)—on.
88	Auto sequence on.
89	HP-IB operator response.
90	Set auto sequence step-delay time.
91	Enable frequency hopping function.
92	Turns off special functions 94/95. Sets knob to 12 incr/rev. Disables AUX connector knob function.
93	Enables manual level control function.
94	Sets knob to 120 increments/revolution.
95	Sets knob to 120 increments/revolution and reconfigures rear-panel AUX connector.
96	Turns modulation oscillator off when all internal modulation functions are off.
97	Turns modulation oscillator on if all modulation functions are off.
98	Turns front-panel readouts and annunciators on.
99	Turns front-panel readouts and annunciators off.
2.0	Disables special function 2.1.
2.1	Executes system clear at power-up and clears registers 1-9.

STATUS

Description

This instruction details how to interpret the Generator's Status codes.

The instrument produces numerically coded messages that are displayed in the STATUS block of the Frequency readout. The messages inform the operator of the following operating conditions:

1. Entry Errors.
2. Hardware Errors (malfunctions).
3. Special Functions enabled.
4. General Status.

The codes are defined in Tables 3-7, 3-8, 3-9 and 3-10 and on the Generator's pull-out information card.

Procedure

To display Status codes, press and hold down the STATUS key.

To display Hardware malfunction codes, select the Blue Key then press and hold down the STATUS key.

Keys and Program Codes

Keys	Codes
STATUS	MS

Indications

The light in the Status key turns on steady if the operator makes an entry error. The Status key light will turn on and blink for hardware malfunctions and general status messages.

The Frequency readout displays:

Special Function codes in the second and third digits from the left. If more than one Special Function is enabled, the readout will sequentially display each code.

The Auto Sequence step-delay value in the fourth through the seventh digit from the right.

Entry Errors, Hardware Malfunctions and general status codes in the first two digits on the right.

NOTE

Error code 99 is only a general indication of a hardware malfunction. Error codes detailing specific hardware failures can be displayed by selecting the Blue Key, then pressing and holding the STATUS key.

FREQUENCY

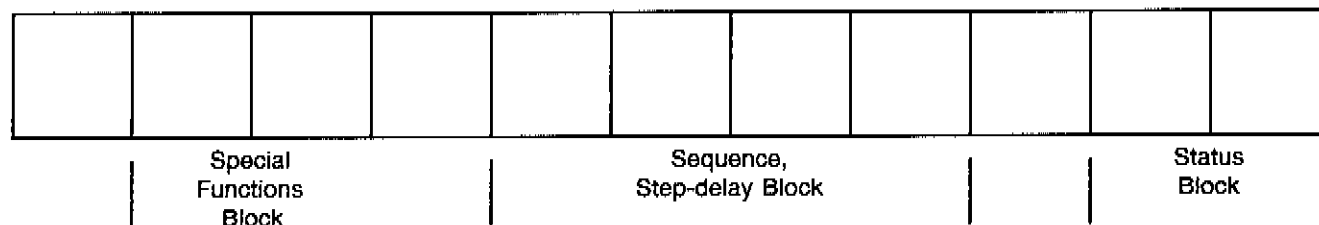

Comments

Hardware malfunctions will cause the STATUS light to turn on and flash. General descriptions of the hardware errors are listed in Table 3-10 entitled "Hardware Malfunctions." Detailed descriptions of malfunctions can be found in the Service Manual (Section VIII), under "SERVICE SHEET BD1—Instrument Level Troubleshooting".

The STATUS key that lights from an entry error, generally goes out after STATUS key has been selected, or after the next valid entry has been made. The error code generated by an incorrect entry is cleared only after the STATUS key is pressed.

Special Functions do not cause the STATUS key light to turn on. Special Function codes are cleared as soon as the Special Function is disabled.



The format of the STATUS message for HP-IB operation is described under the detailed operating instruction "HP-IB STATUS Key Message".

Related Functions

HP-IB Status Key Message

Table 3-9. STATUS CODES

Code	Error Description
00	No error.
01	No reference oscillator input. Check rear-panel INT-EXT switches or refer to the Service Manual, Sec. VIII.
11	FM overmodulated. Resultant modulation index invalid.
12	Crystal oven not heat stabilized. Allow one hour for optimum operating temperature.
13	External reference selected (5 MHz or 10 MHz). See Figure 3-2. Rear Panel Features
14	Reference frequency out of tolerance. Check external frequency source or refer to Service Manual, Sec. VII.
18	BPSK not available when RF FREQ \geq 640 MHz without option 002.
19	PM and BPSK not allowed simultaneously when RF frequency is \geq 640 MHz. PM is turned off.
32	RF frequency is out of generator's range. Range: 1 kHz-2599.999 9996 MHz.
33	Amplitude selected $>$ +19.9 dBm invalid.
34	Amplitude selected $<$ -129.9 dBm invalid.
35	Amplitude selected $>$ +10 dBm (710 mV) when AM is on.
36	Invalid amplitude selected. Output range: 0.072 μ V-999 mV.
37	AM level $>$ 95% invalid.
38	RF frequency $<$ 150 kHz with AM selected invalid.
39	FM MOD level $>$ 100 kHz not allowed when: RF FREQ $<$ 120 MHz or 320 MHz \leq RF FREQ $<$ 640 MHz.
40	FM MOD level $>$ 25 kHz not allowed when: 120 MHz \leq RF FREQ $<$ 160 MHz.
41	FM MOD level $>$ 50 kHz not allowed when: 160 MHz \leq RF FREQ $<$ 320 MHz.
42	FM MOD level $>$ 200 kHz not allowed when RF FREQ $<$ 1280 MHz.
43	Entry ignored. Wrong entry protocol or entry out of Generator's range.
44	Too many significant digits prior to decimal point.
45	Start frequency = stop frequency.
46	Parameter underflow. Defaulted to zero.
47	Marker not within RF start-stop sweep range.
48	Marker not within RF span sweep range.
49	Step size greater than sweep span range.
50	Store/recall error. Register nonexistent or register failure.
51	Recall 0 invalid. (1-9 only).
52	RAM data altered. First good register recalled, special functions are cleared. Re-enter data into storage registers.
53	RAM faulty. Generator executes system clear. Re-enter data for all registers. Refer to Service Manual, Section VIII.
54	Level accuracy unspecified when output is $>$ +10 dBm when AM is on or $>$ +16 dBm when AM is off.
55	Sweep steps $>$ 10,000. Sweep ramp disabled. Sweep (SWP) output equals 0 volts.
56	Invalid special function code.
57	Entry in units of volts not allowed.
59	Sweep span freq out of generator range.
62	Markers not available in modulation sweep.
63	EXT-AC not allowed in BPSK or pulse modulation modes.
64	AM characteristics not specified when: AM MOD FREQ $>$ 10 kHz, or AM MOD FREQ $>$ 5.0 kHz and 1 MHz \leq RF FREQ $<$ 10 MHz, or AM MOD FREQ $>$ 1.5 kHz and 150 kHz $<$ RF FREQ $<$ 1 MHz.
65	Modulation frequency entry out of generator's range. (10 Hz-99.9 kHz.)
66	Modulation frequency increment entry out of range.
67	FM MOD level entry out of range for current RF frequency.
69	ϕ M MOD level entry out of range for current RF frequency.
70	ϕ M MOD level $>$ 100 deg not allowed when: RF FREQ $<$ 120 MHz or 320 MHz \leq RF FREQ $<$ 640 MHz.
71	ϕ M MOD level $>$ 25 deg not allowed when: 120 MHz \leq RF FREQ $<$ 160 MHz.
72	ϕ M MOD level $>$ 50 deg not allowed when: 160 MHz \leq RF FREQ $<$ 320 MHz.
73	PM MOD level $>$ 200 deg not allowed when: RF FREQ $<$ 1280 MHz.
74	FM or PM MOD level entry exceeds generator's resolution. Modulation level defaults to the next lowest available value.
75	RF frequency + offset exceeds generator's range. Special function 11/12 turned off.
77	Special function 93 cannot be invoked with amplitude expressed in units of volts.
78	Special function 93 disabled. Store function not allowed with Special Function 93 enabled.
79	Attenuator setting must be in range of 0 to -135 dB (5 dB increments only).
80	Vernier setting must be in range of +0.1 to +19.9 dBm (0.1 dB increments only).
81	Special function 93 and special function 31 or 32 cannot be active concurrently.
88	Transient malfunction. Indicates transient hardware error occurred. Transient error can be displayed by pressing the Blue Key, then pressing and holding the STATUS key.
99	Hardware malfunction. Refer to Table 3-10. Hardware Error Codes or to Section VIII, BD1—Instrument Level Troubleshooting.

Table 3-10. *HARDWARE ERROR CODES*

Code	Error Description
02	Fractional-N loop unlocked.
03	N loop unlocked.
04	LF sum loop unlocked.
05	FM sum loop unlocked.
06	HF reference sum loop unlocked.
07	HF sum loop unlocked.
08	FM loop unlocked.
61	Modulation oscillator loop unlocked. Refer to Service Manual, Section VIII.
76	Output power out of specification. Refer to Service Manual.
95	ROM malfunction. Refer to paragraph 3-8 "Turn-on" and the detailed operating instruction entitled "Memory Check".
96	RAM malfunction. Refer to paragraph 3-8 "Turn-on" and the detailed operating instruction entitled "Memory Check".
98	Memory malfunction. Refer to paragraph 3-8 "Turn-on" and the detailed operating instruction entitled "Memory Check".
101	ϕM or FM internal I/O error.
102	AM internal I/O error.
103	Modulation oscillator internal I/O error.
104	Modulation oscillator internal I/O error.
105	FM level internal I/O error.
106	AM level internal I/O error.
107	AM or FM level internal I/O error.
108	ϕM level internal I/O error.
109	ϕM level internal I/O error.
110	RF off function internal I/O error.
111	RF vernier internal I/O error.
112	RF vernier internal I/O error.
114	Output attenuator internal I/O error.
115	RF frequency internal I/O error.
116	RF frequency internal I/O error.
117	RF frequency internal I/O error.
118	RF frequency internal I/O error.
119	RF frequency internal I/O error.
120	External doubler drive.
121	IO decode error.

Troubleshooting help can be found in Section VIII under BD1—Instrument Level Troubleshooting.

STORE-RECALL

Description

This instruction details how to store a full front-panel configuration (including "hidden" parameters) in any of the Generator's storage registers.

Nine registers are available (Registers 1-9), each capable of storing a full, front-panel configuration.

The Generator's hidden parameters are defined as the parameters not currently displayed on the front-panel: Increment step sizes, Start-Stop and Span frequencies, etc. Markers and most Special Functions cannot be stored in the instrument's registers.

Procedure

To store a front-panel configuration, press STORE and enter a register number (1-9).

To recall a front-panel configuration from storage, press RECALL and enter a register number (1-9).

Example

Store the front-panel setup in Register 2 then recall it.

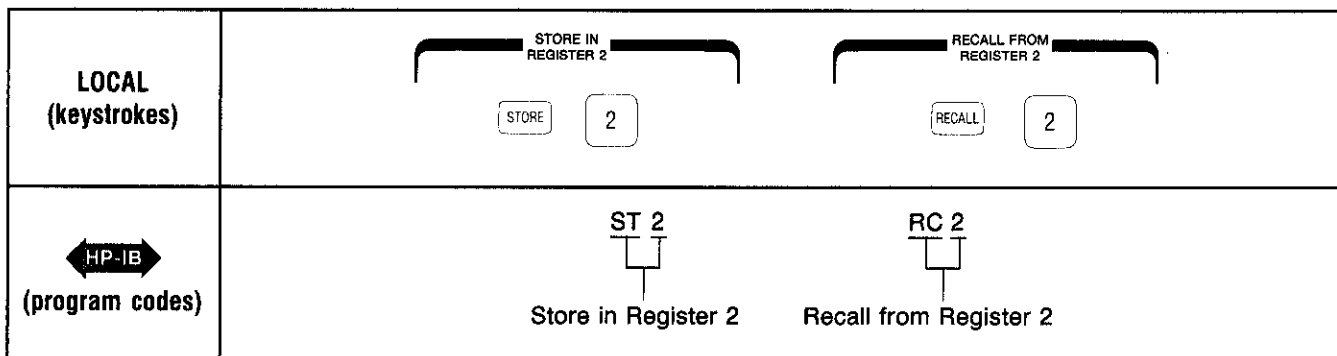

Keys and Program Codes

Keys	Codes
STORE	ST
RECALL	RC

Comments

Marker frequencies and Special Functions cannot be stored in individual registers (with the exception of Special Function 41); they are global parameters. Once established they apply to any set of parameters recalled from storage. A Marker's On-Off status, however, can be stored in a register.

The Single sweep mode cannot be stored. However, the other sweep parameters associated with a Single sweep can be stored.

The Sequence feature allows the contents of each register to be recalled, one register at a time, according to a predetermined order. The Auto-Sequence feature is similar except that once initiated, the function recalls the registers in a continuous cycle. For more information refer to the detailed operating instruction entitled "Sequence".

The storage registers can also store frequency values that are used in the Frequency Hopping mode (Special Function 91).

Related Functions

Frequency Hopping
Frequency Copying
Sequence
Sequence, Step-Delay

System Clear (Special Function 00, 2.0 and 2.1)

Description

This instruction details how to initialize the instrument's front-panel functions upon power-up or during normal operation. Also listed in this instruction is the Generator configuration after a system clear has been executed.

Procedure

To execute the System Clear command, press Blue Key, SPECIAL, and 00.

The Generator, upon power-up, normally recalls the last selected front panel configuration (prior to turning the instrument off). However, if Special Function 2.1 is invoked before the Generator is turned off, then upon power-up the instrument will execute a system clear and clear all front-panel storage registers.

Special Function 2.1 can be disabled by selecting Blue Key, SPECIAL and 2.0.

SYSTEM CLEAR CONFIGURATION

FUNCTION MODE FREQUENCY
 RF Frequency 100.0 MHz
 RF Frequency Knob Resolution 1.0 MHz
 RF Frequency Increment 1.0 MHz/step

MODULATION MOD OFF
 Modulation Frequency 1 kHz
 Modulation Freq. Knob Resolution 1 kHz
 Modulation Frequency Increment 0.1 kHz/step

AM Level 10%
 AM Level Increment 1.0% step

FM Level 20.0 kHz
 FM Level Increment 1.0 kHz

ϕ M Level 20 deg.
 ϕ M Level Increment 1 deg/step

RF SWEEP MODE MODE OFF
 Start Frequency 1.0 MHz
 Stop Frequency 639.0 MHz
 Span Frequency 10.0 MHz
 Set Size 2.0 MHz

Values for Increment and Knob resolution for the above listed RF Sweep parameters are the same as the FREQUENCY function.

Steps 100 steps
 Time/Step 0.5 ms
 Markers 1-5 0.0 MHz

MODULATION SWEEP MODE Off
 Start Frequency 0.1 kHz
 Stop Frequency 10 kHz
 Span Frequency 0.1 kHz
 Steps 100 Steps
 Set Size 0.1 kHz
 Time/Step 2 ms

AMPLITUDE-30.0 dBm
 Amplitude Increment0.1 dB/step
 Amplitude-Knob Resolution1.0 dB
 Storage Registers 1-9Contents not altered*
 Sequency Sequence not altered
 Special FunctionsAll off
 KnobOff
 Sequence, Step Delay1 ms
 Service Request ConditionHP-IB Error only
 RQS MaskCleared
 Status ByteUnchanged
 Execution ModeImmediate
 Trigger ConfigurationCleared
 Remote Stepped SweepOff

The HP-IB "Clear" command will also execute a Generator System Clear. The Generator responds equally to DCL and SDC bus commands.

*Cleared at power-up if Special Function 2.1 was enabled.

Section 4 PERFORMANCE TESTS

4-1. INTRODUCTION

The procedures in this section test the instrument's electrical performance using the specifications from Table 1-1 as the performance standards. All tests can be performed without access to the interior of the instrument.

NOTE

If the performance tests are to be valid the following conditions must be met:

- a. The Signal Generator must have a 1-hour warmup.*
- b. The mains (line) voltage must be within 90 to 126V or 198 to 252V at 48 to 66 Hz.*
- c. The ambient temperature must be +15 to +45 degrees C for the Level Accuracy and Flatness Test.*

Before aging rate tests are performed, the Generator must have a 10 day warmup, if it has been disconnected from the Mains power for more than 24 hours, or if the Generator has been disconnected from the Mains power for less than 24 hours, it must have a 24 hour warmup.

4-2. EQUIPMENT REQUIRED

Equipment required for the performance tests is listed in the Recommended Test Equipment table in Section 1. Any equipment that satisfies the critical specifications given in the table may be substituted for the recommended model(s).

4-3. TEST RECORD

Results of the performance tests may be tabulated on the Test Record at the end of the procedures. The Test Record lists all of the tested specifications and their acceptable limits. The results recorded at incoming inspection can be used for comparison in periodic maintenance and troubleshooting and after repairs or adjustments.

4-4. OPERATION VERIFICATION

The Operation Verification procedure allows the operator to make a quick evaluation of the Generator's performance. These tests provide the operator with a 90% assurance that the Generator is operating within its guaranteed specifications.

After a repair or adjustment has been made, refer to Table 4-1 to see what further adjustments may be required before the Operation Verification procedure is performed.

Table 4-1. Recommended Performance Tests After Adjustments or Repairs

Repaired Section	Performance Test Number							
	1	2	3	4	5	6	7	8
Output Section	X	X		X	X	X	X	X
Reference Section	X				X	X		
Fractional-N Loop	X				X	X		
Low Frequency Loops	X				X	X		
High Frequency Loops	X				X	X		
Modulation Section	X	X						
Phase Modulation Section	X		X					X
Power Supply	X				X			
Digital Control Unit (DCU)	X							

PERFORMANCE TEST 1

OPERATION VERIFICATION

Description

All portions of the instrument are checked to verify that they are functioning normally. This procedure can be used for post-repair confidence testing and for instrument checkout. It provides a 90% assurance that the instrument complies with its specified operating characteristics.

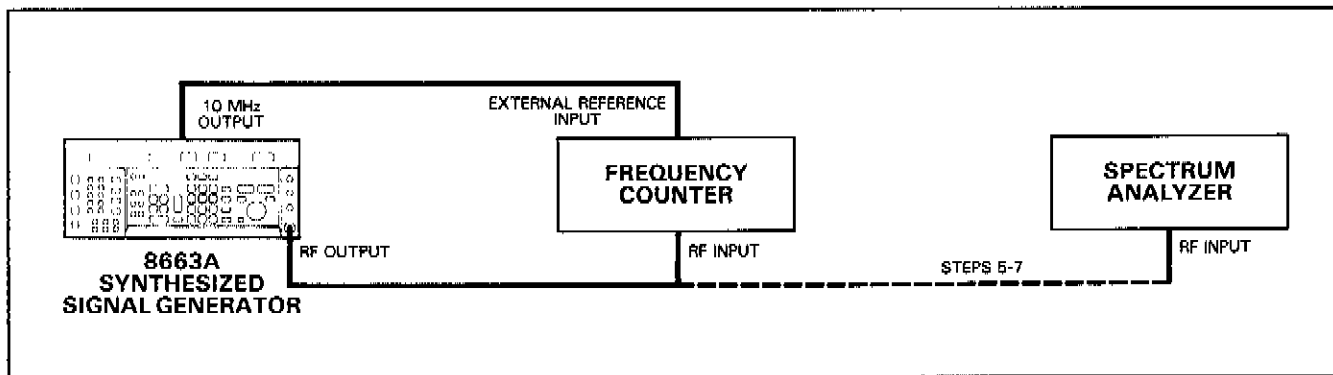

Figure 4-1. Operation Verification Amplitude and Frequency Test Setup

Equipment

- Frequency Counter HP 5342A
- Spectrum Analyzer HP 8565A
- Modulation Analyzer HP 8901A
- Audio Analyzer HP 8903B

Procedure

1. Connect the instruments as shown in Figure 4-1 and apply power.
2. Initialize the Signal Generator using Special Function 00. Connect a cable from the Generator's rear-panel, reference oscillator output (10 MHz OUTPUT) to the external time base input of the frequency counter.
3. Set the Generator's amplitude to -10.0 dBm and frequency to the values given in the following table. The counter's reading should be the frequency that is set plus the resolution error for the counter being used.

Check Frequencies (MHz)
100.0
140.0
200.0
300.0
400.0
600.0
800.0
1000.0
2000.0

4. Set the Generator's frequency to 111.111 111 1 MHz and set the RF Frequency Increment value to 111.111 111 1 MHz. The counter's reading should be the same value as the Generator's FREQUENCY display. Press the INCREMENT (up) key until the maximum frequency is reached. Check that the Generator's FREQUENCY display and the counter's display are the same for each step as shown in the table below. Then press the INCREMENT (down) key to decrease the Generator's frequency. Check that the Generator's FREQUENCY display and the counter's readings are the same for each step as shown in the table below as the frequency is decreased.

Output Frequencies (MHz)
111.111 111 1
222.222 222 2
333.333 333 3
444.444 444 4
555.555 555 5
666.666 666 6
777.777 777 6
888.888 888 8
999.999 999 8
1 111.111 111

5. Connect the Signal Generator's RF OUTPUT to the Spectrum Analyzer's RF INPUT. Set the Generator to sweep from 0.1 to 800 MHz in 1000 steps at 100 ms/step (AUTO mode). Set the Generator's amplitude to +10 dBm. Set the spectrum analyzer to a center frequency of 400 MHz with 100 MHz span/division and a +10 dBm reference level.

The display should be a continuous sweep without jumps or gaps. Harmonics can be seen over most of the sweep and should be more than 30 dB below the carrier. The level of the swept signal may vary between +8.9 dBm and +11.1 dBm.

Set the Generator to sweep from 800 MHz to 1600 MHz. Set the spectrum analyzer center frequency to 1200 MHz. Verify sweep continuity. The level of the swept signal may vary between +8.5 dBm to +11.5 dBm.

Set the Generator to sweep from 1600 MHz to 2559 MHz. Set the spectrum analyzer center frequency to 1200 MHz. Verify sweep continuity. The swept signal may vary between +8.5 dBm and +11.5 dBm.

6. Set the Generator's sweep mode to OFF and amplitude to +5 dBm. Set the Generator's frequency to 0.1 MHz and enable the knob to change frequency with a 10 MHz resolution. Set the spectrum analyzer's amplitude scale to maximum resolution.

NOTE

This step checks only the level flatness, not absolute accuracy.

Slowly tune the Generator through its entire frequency range while observing the output level on the spectrum analyzer. The output level should not vary more than ± 1.0 dB.

7. Set the Generator's output amplitude to +19 dBm and RF frequency to the values shown in the following table.

RF Frequency
100 MHz
320 MHz
1000 MHz
2500 MHz

At each frequency setting adjust the spectrum analyzer to display the Generator's signal. Set the Generator's signal peak to the spectrum analyzer's reference level. Enable the Generator's knob to vary the output amplitude in 0.1 dB steps. Slowly decrease the Generator's output amplitude to +5.1 dBm. The signal level on the spectrum analyzer should decrease smoothly without jumps or upward steps.

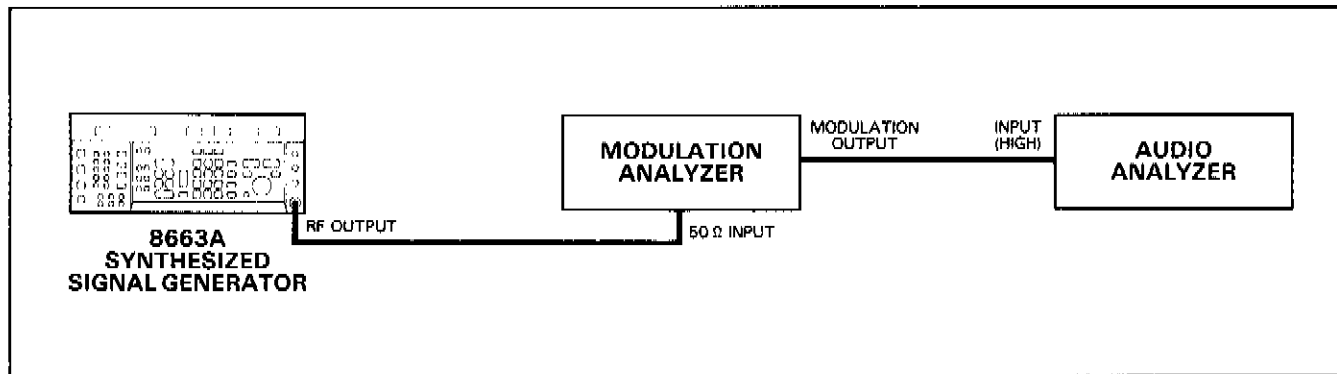

Figure 4-2. Operation Verification Modulation Accuracy and Distortion Test Setup.

8. Connect the instruments as shown in Figure 4-2 and apply power.
9. Set the Generator's output to +10 dBm and the AM Modulation Rate to 1 kHz. Select the 8901A Modulation Analyzer's AM Measurement mode. Enable the 8903B Audio Analyzer's distortion (DISTN) function and switch in the 30 kHz low pass filter. Set the Signal Generator's RF Frequency and AM Depth to the values indicated in the following table, and verify that the Generator's AM Level Indicator Accuracy is within $\pm(6\%$ of setting +1% AM). Also, verify that the AM distortion does not exceed the specified values. Refer to the following table for the required values.

RF Frequency	AM Depth			Maximum AM Distortion
	Setting	Min	Max	
100 MHz	10%	8.4	11.6	< 2%
100 MHz	50%	46.0	54.0	< 3%
100 MHz	90%	83.6	96.4	< 4%
320 MHz	10%	8.4	11.6	< 2%
320 MHz	50%	46.0	54.0	< 3%
320 MHz	90%	83.6	96.4	< 4%
1000 MHz	10%	8.4	11.6	< 2%
1000 MHz	50%	46.0	54.0	< 3%
1000 MHz	90%	83.6	96.4	< 4%
1300 MHz	10%	8.4	11.6	< 2%
1300 MHz	50%	46.0	54.0	< 3%
1300 MHz	90%	83.6	96.4	< 4%

10. Turn off the Signal Generator AM modulation and set the output amplitude to +16 dBm, and the FM MOD FREQ to 1 kHz. Select the 8901A Modulation Analyzer's FM Measurement mode.

Set the Signal Generator's RF frequency and FM deviation to the values in the following table. Verify that the FM distortion, as read on the Audio Analyzer, does not exceed 1.00%.

RF Frequency	FM Peak Deviation
100 MHz	25 kHz
100 MHz	100 kHz
320 MHz	25 kHz*
320 MHz	100 kHz
1300 MHz	20 kHz*
1300 MHz	100 kHz
1300 MHz	400 kHz

* Enable Audio Analyzer's 80 kHz LP filter.

- Set the Generator's FM rate to 20 kHz and perform the distortion measurements again. Verify that the FM distortion does not exceed 1.7%. Use the frequencies listed in the previous table.
- Set the Signal Generator's FM rate to 1 kHz. Set the Generator's RF frequency and FM peak deviation to the values in the following table. Verify that the FM Level Indicator accuracy's is within $\pm(7\%$ of setting +10 Hz).

RF Frequency	FM Peak Deviation		
	Setting	Min	Max
150 MHz	25 kHz	23.24	26.76
200 MHz	50 kHz	46.49	53.51
500 MHz	100 kHz	92.99	107.01
1000 MHz	200 kHz	185.99	214.01
1300 MHz	400 kHz	371.99	428.01

NOTE

The following step should be performed only if the Signal Generator contains Option 002.

- Set the Signal Generator's output amplitude to +16 dBm. Select the 8901A Modulation Analyzer's Φ M Measurement mode.

Turn off the Signal Generator's FM modulation. Set the Φ M modulation rate to 1 kHz. Set the Signal Generator's peak deviation and RF frequency to the values in the following table. Verify that the Φ M Level Indicator's accuracy is within $\pm(12\%$ of setting +3% of full scale). Also, verify that the Φ M distortion, as read on the Audio Analyzer, does not exceed 10%.

RF Frequency	Peak Deviation		
	Setting	Min	Max
100 MHz	100 deg	85.0 deg (1.48 rad)	115.0 deg (2.01 rad)
150 MHz	25 deg	21.3 deg (0.37 rad)	28.8 deg (0.50 rad)
200 MHz	50 deg	42.5 deg (0.74 rad)	57.5 deg (1.00 rad)
500 MHz	100 deg	85.0 deg (1.48 rad)	115.0 deg (2.01 rad)
1000 MHz	200 deg	170.0 deg (2.97 rad)	230.0 deg (4.01 rad)
1300 MHz	400 deg	340.0 deg (5.93 rad)	460.0 deg (8.03 rad)

- 14. Turn off the Signal Generator's Φ M modulation. Set the Generator's RF frequency to 640 MHz and the output amplitude to +10 dBm. Reconnect the spectrum analyzer as shown in Figure 4-1 and set the span to 20 kHz/division with a center frequency of 640 MHz. Center the signal on the spectrum analyzer's display and adjust the signal peak to the spectrum analyzer's amplitude reference level. Set the BPSK modulation frequency to 10 kHz with an increment value of 1 kHz. Increment the modulation frequency to 99 kHz using the Increment up key. Verify that the center frequency is greater than 20 dB down from the reference level.
- 15. Turn off the Signal Generator's BPSK modulation. Set the Generator's output amplitude to +10 dBm and the RF frequency to 2500 MHz. Center the 2500 MHz signal on the spectrum analyzer's display.

Set the PULSE modulation frequency to 100 Hz. Set the spectrum analyzer as follows:

```

AMPLITUDE SCALE..... 10 dB/DIV
REF LEVEL ..... +10 dBm
INPUT ATTEN ..... 30 dB
FREQ SPAN/DIV ..... 0
RESOLUTION BW ..... 10 kHz
TIME/DIV ..... 2 ms
TRIGGER ..... VIDEO

```

Tune the spectrum analyzer for the greatest amplitude signal. Adjust the Video Filter for minimum noise and verify that the signal is a square wave. Adjust the Reference Level fine tune, if necessary, to place signal peak on the top reference line of the display. Change the INPUT ATTEN to 10 dB and note how far the bottom of the square wave is below the reference level. Add 20 dB to this amount to determine the pulse on/off ratio. Verify that the ratio is greater than 85 dB.

PERFORMANCE TEST 2

AM and FM TESTS

Specification

Electrical Characteristics	Performance Limits	Conditions
Amplitude Modulation		
Depth	0 to 95%	Output level of +10 dBm and below ¹
Resolution	0.1%	
Incidental Φ M	0.15 radians peak 0.33 radians peak	0.1 to 640 MHz; 30% AM 640 to 1280 MHz; 30% AM
Indicator Accuracy	\pm (6% of reading \pm 1%AM)	Depth \leq 90% AM; for AM rates of 400 Hz and 1 kHz.
AM Rates	See Supplemental Characteristics	
AM Distortion (0.15 to 2560 MHz)	2% 3% 4%	0 to 30% AM 30 to 70% AM 70 to 90% AM
Frequency Modulation		
FM Rates: Internal External ac External dc	10 Hz to 99.9 kHz 20 Hz to 100 kHz dc to 100 kHz	See Supplemental Characteristics 1 dB bandwidth 1 dB bandwidth
Maximum Peak Deviation (external ac and internal)	The smaller of: 100 kHz or $f_{mod} \times 500$ 25 kHz or $f_{mod} \times 125$ 50 kHz or $f_{mod} \times 250$ 100 kHz or $f_{mod} \times 500$ 200 kHz or $f_{mod} \times 1000$ 400 kHz or $f_{mod} \times 2000$	0.1 to 120 MHz 120 to 160 MHz 160 to 320 MHz 320 to 640 MHz 640 to 1280 MHz 1280 to 2560 MHz

Electrical Characteristics	Performance Limits	Conditions
Maximum Peak Deviation (external dc)	100 kHz 25 kHz 50 kHz 100 kHz 200 kHz 400 kHz	0.1 to 120 MHz 120 to 160 MHz 160 to 320 MHz 320 to 640 MHz 640 to 1280 MHz 1280 to 2560 MHz
Indicator Accuracy	$\pm(7\% \text{ of reading} + 10 \text{ Hz})$	50 Hz to 20 kHz rates
FM Resolution	100 Hz 200 Hz 400 Hz	0.1 to 640 MHz 640 to 1280 MHz 1280 to 2560 MHz
Incidental AM (AM sidebands)	-72 dBc	1 kHz rate and 20 kHz deviation 10 to 2560 MHz
FM Distortion	1.00% 1.70%	400 Hz or 1 kHz rates all other rates ≤ 20 kHz
Center Frequency Accuracy and Long Term Stability	Same as CW mode	Internal and external mode only.

¹ AM is possible above these output levels but not specified.

Description

All AM and FM specifications are checked by measuring the specified parameters on a modulation analyzer. Distortion is checked by measuring the demodulated output from the modulation analyzer.

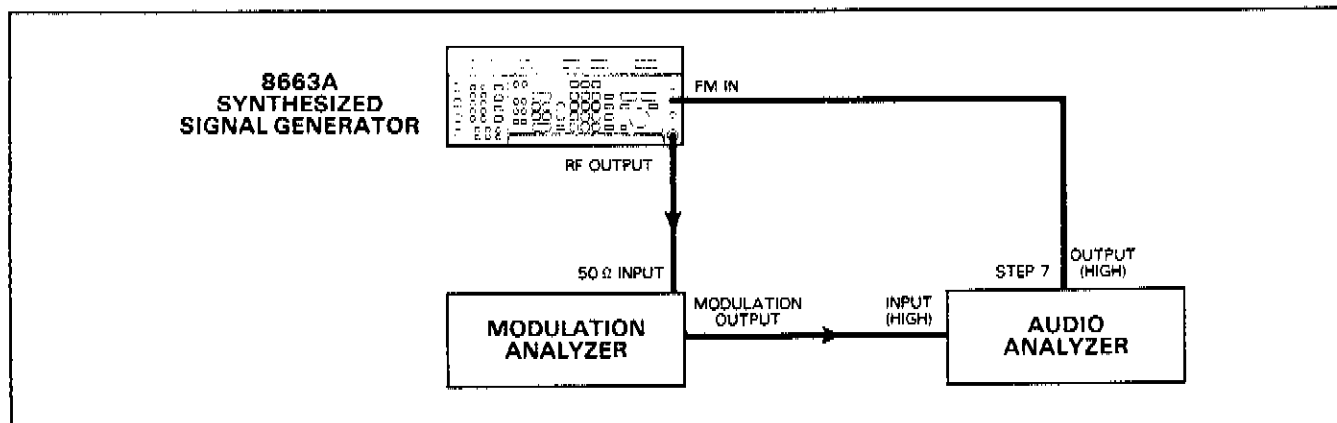

Figure 4-3. AM and FM Test Setup

Equipment

Modulation Analyzer	HP 8901A
Audio Analyzer	HP 8903B

Procedure

1. Connect the instruments as shown in Figure 4-3 and apply power. Set the Generator's output amplitude to +10.0 dBm. Set the Modulation Analyzer as follows:
 - HP FILTER 300 Hz
 - LP FILTER 3 kHz
 - FM DE-EMPHASIS OFF
 - DETECTORS PEAK+
 - AUTOMATIC OPERATION ON
 - MEASUREMENT MODE AM

AM Indicator Accuracy

2. Set the Generator to 100.0 MHz, AM with INT 1k source. Set AM% to the values in the first column of the table below. Check that the modulation analyzer's readings are within the specified values given in the table below.

AM Indicated (%) For 100 MHz	Results		
	Min	Actual	Max
10	8.4	_____	11.6
30	27.2	_____	32.8
70	64.8	_____	75.2
90	83.6	_____	96.4

Repeat with the Generator set to 500.0 MHz, 1.0 GHz and 1.3 GHz.

AM Indicated (%) For 500 MHz	Results		
	Min	Actual	Max
10	8.4	_____	11.6
30	27.2	_____	32.8
70	64.8	_____	75.2
90	83.6	_____	96.4

AM Indicated (%) For 1.0 GHz	Results		
	Min	Actual	Max
10	8.4	_____	11.6
30	27.2	_____	32.8
70	64.8	_____	75.2
90	83.6	_____	96.4

AM Indicated (%) For 1.3 GHz	Results		
	Min	Actual	Max
10	8.4	_____	11.6
30	27.2	_____	32.8
70	64.8	_____	75.2
90	83.6	_____	96.4

Re-check accuracy at 100.0 MHz using the Generator's INT 400 source and the Modulation Analyzer's 50 Hz HP filter.

AM Indicated (%) For 100 MHz	Results		
	Min	Actual	Max
10	8.4	_____	11.6
30	27.2	_____	32.8
70	64.8	_____	75.2
90	83.6	_____	96.4

Incidental Φ M

- Set the Generator to 30% AM with INT 1k source and output level of +10 dBm. Use the modulation analyzer's 300 Hz HP filter and 3 kHz LP filter. Set the Generator's frequency and modulation analyzer's mode as stated in the table below. Check for the readings given in the table below.

8663A Frequency	Modulation Analyzer Mode	Results	
		Actual	Max
600.0 MHz	Φ M	_____	0.15 rad
1000.0 MHz	Φ M	_____	0.1 rad
1300.0 MHz	Φ M	_____	0.33 rad

AM Distortion

- Connect a cable from the MODULATION OUTPUT of the modulation analyzer to the input of the distortion analyzer. Set the distortion analyzer to DISTN. Set the Generator to 100.0 MHz. Set the modulation Analyzer to AM. Set the Generator to INT 1k source and the AM depths in the table below. Measure distortion at each setting and compare it to the specified value given in the table.

AM Indicated (%) For 100 MHz	Results	
	Actual	Max
30	_____	2.0%
70	_____	3.0%
90	_____	4.0%

Repeat the distortion measurements at frequency setting of 600.0 MHz, 1.0 GHz, and 1.3 GHz.

AM Indicated (%) For 600 MHz	Results	
	Actual	Max
30	_____	2.0%
70	_____	3.0%
90	_____	4.0%

AM Indicated (%) For 1.0 GHz	Results	
	Actual	Max
30	_____	2.0%
70	_____	3.0%
90	_____	4.0%

AM Indicated (%) For 1.3 GHz	Results	
	Actual	Max
30	_____	2.0%
70	_____	3.0%
90	_____	4.0%

FM Indicator Accuracy

- Set the Generator to 100.0 MHz and FM mode with the INT 1kHz source. Set FM deviation to the values in the table below. Set the modulation analyzer to FM mode. Check that the readings are within the specified values given in the table.

FM Indicated	Results		
	Min	Actual	Max
10.0 kHz	9.29 kHz	_____	10.71 kHz
30.0 kHz	27.89 kHz	_____	32.10 kHz
70.0 kHz	65.09 kHz	_____	74.91 kHz
100.0 kHz	92.99 kHz	_____	107.01 kHz

See note
→

Incidental AM

- Set the Generator to 100.0 MHz, +10 dBm amplitude, and FM modulation off. Set the modulation analyzer to AM mode with 300 Hz high pass filter, 3 kHz low pass filter, and the PEAK+ detector selected. The modulation analyzer's reading must be less than .05% (-72 dBc). If the reading is too high, it means the residual AM of the modulation analyzer (or possibly of the Generator) is too high to make the incidental AM measurement.

Determine the cause of the high residual AM before proceeding. If the reading is less than .05% (-72dBc), set the Generator to FM mode, 20 kHz deviation with internal 1 kHz source and output power at +10 dBm. Set the Generator to the frequency settings in the table below. At each setting measure the incidental AM with the modulation analyzer and check that the reading is less than the value given in the table below.

Frequency Setting For 1.0 GHz	Results	
	Actual	Max
100.0 MHz	_____	.05%
1.0 GHz	_____	.05%
1.3 GHz	_____	.05%

FM Distortion

7. Connect the instruments as shown in Figure 4-3. Set the Generator to 100.0 MHz, 100 kHz FM deviation and EXT AC source. Set the Audio Analyzer's output frequency to 1 kHz. Adjust the output level of the Audio Analyzer for approximately 1.49V or until the EXT MOD HI/LO indicators on the signal generator go out. Set the modulation analyzer to measure FM with all filters off. The measured distortion should be less than 1.0%.

Set the Audio Analyzer's output to 20 kHz. The measured distortion should be less than 1.7%.

Frequency Setting	Results 1 kHz Rate		Results 20 kHz Rate	
	Actual	Max	Actual	Max
100.0 MHz	_____	1.00%	_____	1.70%
320 MHz	_____	1.00%	_____	1.70%
329.9 MHz	_____	1.00%	_____	1.70%
640 MHz	_____	1.00%	_____	1.70%
1300 MHz	_____	1.00%	_____	1.70%

8. If the Generator failed any of the previous tests, perform the "AM and FM Adjustments" or "ALC Loop Bandwidth Adjustment" in Section 5 or troubleshoot with the procedures described in Service Sheet BD7.

Incidental AM } 18 Apr 91
 Same note as in 8662A
 Manual pg. 4-8. Also FM ON
 Not off as returned. per tel
 con w/ Gray Crostrey HP (spokane)
 (509) 921-3365 - He will send A.I.S.
 corrected pages.
 A.R. Sawaya
 MLEE/7998

PERFORMANCE TEST 3

PHASE MODULATION TEST (Option 002 only)

Specification

Electrical Characteristics	Performance Limits	Conditions
Phase Modulation		
Peak Phase Deviation	100 degrees 25 degrees 50 degrees 100 degrees 200 degrees 400 degrees	0.1 to 120 MHz 120 to 160 MHz 160 to 320 MHz 320 to 640 MHz 640 to 1280 MHz 1280 to 2560 MHz
Resolution	1 degree 2 degrees 4 degrees	0.1 to 640 MHz 640 to 1280 MHz 1280 to 2560 MHz
Indicator Accuracy	$\pm(12\%$ of setting + 3% of full scale)	for rates given below
Rates ¹	10 kHz 100 kHz 2 MHz 5 MHz 10 MHz	0.15 to 10 MHz 10 to 50 MHz 50 to 220 MHz 220 to 640 MHz 640 to 2560 MHz
Distortion	10%	for rates given above
¹ For external DC coupling. For external AC coupling, 600 ohm input, minimum rate is 20 Hz. For external AC coupling, 50 ohm input, minimum rate is 200 Hz. For internal modulation source, minimum rate is 10 Hz.		

Description

Phase modulation specifications are checked by using a modulation analyzer to measure deviation. The demodulated output from the modulation analyzer is measured by an audio analyzer to check distortion. At rates and RF frequencies above the range of the modulation analyzer, a spectrum analyzer is used to check phase deviation accuracy.

NOTE

This Procedure does not measure distortion at high rates. This measurement is beyond the capability of commercially available test equipment. Performance is verified at the factory using a special test fixture.

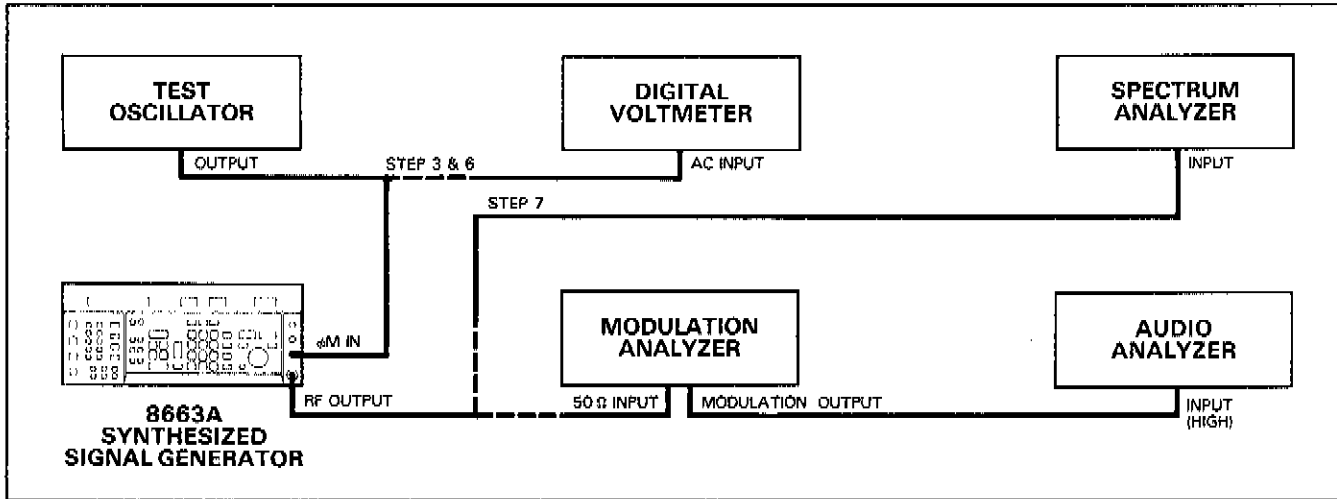

Figure 4-4. Phase Modulation Test Setup

Equipment

Modulation Analyzer	HP 8901A
Audio Analyzer	HP 8903B
Function Generator	HP 3325A
Spectrum Analyzer	HP 8565A
Digital Voltmeter (DVM)	HP 3478A

Procedure

1. Connect the equipment as shown in Figure 4-4 and apply power. Set the modulation analyzer to measure phase modulation using the 50 Hz HP FILTER and PEAK+ DETECTOR. Key in 1.745 and push the %RATIO key which will cause the display to read in degrees.
2. Set the Signal Generator to 0 dBm AMPLITUDE and phase modulation with EXT AC source. Enable Special Function 71 to set the phase modulation input impedance to 600 ohms.
3. Set the function generator output amplitude to 0.707 Vrms ±1 mV at the 600 ohm output. Use the DVM to measure the output of the function generator.
4. Set the audio analyzer to measure distortion.
5. Set the Generator's FREQUENCY and ΦM MOD LEVEL to the values in the table below. Set the frequency of the function generator to the value given in the table. For each set of values check the following:
 - a. The modulation analyzer reading should be between the maximum and minimum values given in the table.
 - b. Distortion should be less than 10%.

RF Frequency (MHz)	ΦM Setting (degrees)	Test Oscillator (kHz)	Results (degrees)		
			Max.	Actual	Min.
100	100	1	85.00	_____	115.00
150	25	10	21.25	_____	28.75
300	50	20	42.50	_____	57.50
500	100	20	85.00	_____	115.00
1000 ¹	200	20	170.00	_____	230.00
1300	400	20	340.00	_____	460.00

¹ At these settings the modulation analyzer may autorange to the highest phase modulation range which does not give enough output to drive the distortion analyzer. If the distortion analyzer reading is erratic, push the ΦM key on the modulation analyzer and it will set itself to the correct range.

6. Set the function generator to 10 MHz and +10 dBm amplitude into accurate 50 ohm load. Use the 50 ohm output and disconnect the voltmeter so the signal goes directly from the function generator to the Generator ΦM IN connector.
7. Disconnect the cable from the modulation analyzer's input and connect the cable to the spectrum analyzer's input as shown in Figure 4-4.
8. Enable the Generator's Special Function 70 (50 ohm phase modulation input impedance) and set the phase modulation level to 82 degrees.
9. Set the Generator to the FREQUENCY settings in the first column of the table below. Tune the spectrum analyzer to center the signal using 10 MHz/division frequency span.

At each frequency setting view the carrier and the first pair of sidebands in the 1 dB/div mode. On the Generator, use the knob or the increment keys to change the phase modulation level setting in 1 degree steps. Change the phase modulation setting to whatever value is required to make the first sidebands equal in amplitude to the carrier. Record this setting in the Actual column of the table. It should be between or equal to the Min. and Max. values given.

RF Frequency (MHz)	Results (degrees)		
	Max.	Actual	Min.
500.0	73	_____	91
439.9	73	_____	91
449.9	73	_____	91
639.9	73	_____	91

10. Set the Generator's FREQUENCY and phase modulation level to the values in the table below. Tune the spectrum analyzer to view the signal in 10 dB/div mode. Change the Generator's phase modulation setting to the value which results in minimum carrier as observed on the spectrum analyzer. Record the setting in the Actual column of the table.

RF Frequency (MHz)	Φ M Setting (degrees)	Results (degrees)		
		Max.	Actual	Min.
1000.0	138	116	_____	160
2000.0	332	281	_____	383

PERFORMANCE TEST 4

PULSE MODULATION TEST

Specification

Electrical Characteristics	Performance Limits	Conditions
Pulse on/off ratio	85 dB 80 dB	>640 MHz 50 MHz to 640 MHz ¹
Pulse rise and fall time (10 to 90%)	250 ns 800 ns 100 ns	50 MHz to 120 MHz 120 MHz to 640 MHz > 640 MHz
Pulse repetition frequency Internal (50% duty cycle)	10 Hz to 99.9 kHz	
External	10 Hz to 2 MHz	50 MHz to 640 MHz >640 MHz
Minimum Pulse width)	1 μ s	< 50% duty cycle

¹ Pulse modulation is available below 50 MHz but is unspecified.

Description

Pulse modulation rise and fall is measured by detecting the RF output and viewing the detected pulse on an oscilloscope. On/off ratio is measured by viewing the signal on a spectrum analyzer in zero scan mode.

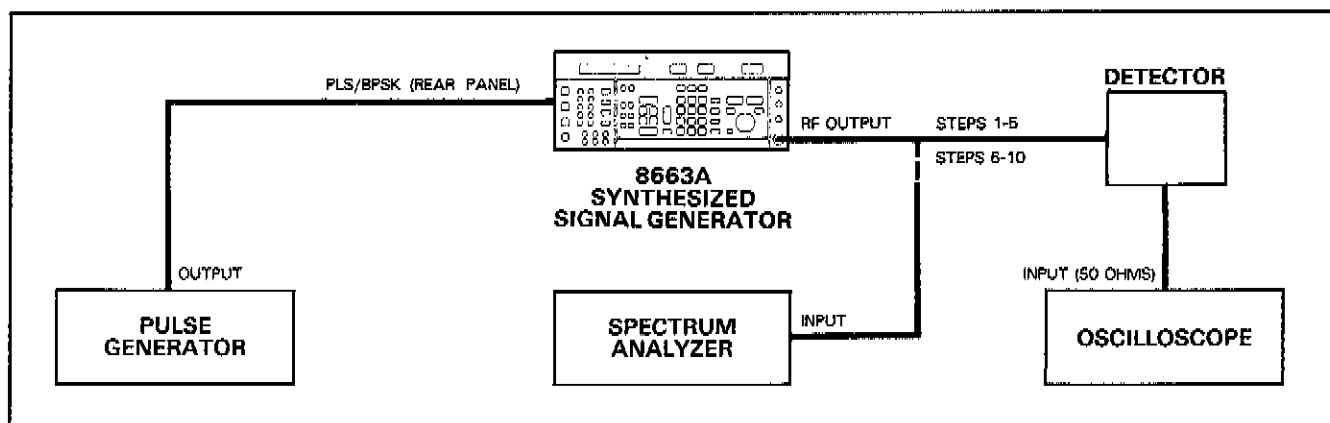

Figure 4-5. Pulse Modulation Test Setup

Equipment

Detector, RF	HP 8470B
Spectrum Analyzer	HP 8565A
Oscilloscope	HP 1741A
Pulse Generator	HP 8111A

Procedure

1. Connect the equipment as shown in Figure 4-5.
2. Set the pulse generator's frequency to 5 MHz and duty cycle to 50%. Use the amplitude and offset controls to produce a 0 to +3.5V pulse.
3. Set the Generator's frequency to 500.0 MHz and amplitude to +10 dBm. Enable pulse modulation with EXT DC mode.
4. View the detected pulses on the oscilloscope. Use the 50 ohm input impedance setting. Adjust volts/division and vertical sensitivity so the pulse levels are on the upper and lower graticule lines. Then measure the transition time between the upper and lower set of dashed lines on the screen which represent the 10% and 90% amplitude points.

Measure both the leading and trailing edges and record the measured values in the table below.

Generator Frequency	Leading Edge		Trailing Edge	
	Actual	Specification	Actual	Specification
500.0 MHz	_____	< 800 ns.	_____	< 800 ns.
1.0 GHz	_____	< 100 ns.	_____	< 100 ns.
2.0 GHz	_____	< 100 ns.	_____	< 100 ns.

5. Repeat the measurements in step 4 at frequency settings of 1.0 GHz and 2.0 GHz.
6. Connect the RF output of the Generator directly to the input of the spectrum analyzer.
7. Set the Generator's frequency to 100.0 MHz and the pulse generator's rate to 10 Hz.
8. Tune in the signal on the spectrum analyzer and set the spectrum analyzer as follows:
Zero span, 10 kHz resolution BW, 20 ms/div sweep speed, video sweep trigger, 30 dB input attenuation, +10 dBm reference level
9. The spectrum analyzer should display a square wave. Adjust the fine tuning to peak the signal and adjust the trigger level to stabilize the signal. Adjust the fine control so the top of the square wave is at the reference level. This establishes the "on" signal at the reference level.
10. Change the input attenuation of the spectrum analyzer to 10 dB which also changes the reference level to -10 dBm. Note how many dB from the reference level the lower level of the square wave is located. Add 20 dB to this number (expressed as a positive number) and record the result as the on/off ratio in the table below.
11. Repeat the measurement in steps 8, 9 and 10 for each of the frequency settings in the table.

Generator Frequency	On/Off Ratio	
	Actual	Specification
100.0 MHz	_____	> 80
500.0 MHz	_____	> 80
1.0 GHz	_____	> 85
2.0 GHz	_____	> 85

PERFORMANCE TEST 5

BPSK TEST

Specification

Electrical Characteristics	Performance Limits	Conditions
Carrier null 100 kHz Square wave	20 dBc	120-640 MHz ¹
	17 dBc	640-2560 MHz, (Option 002 only: +15 to +35 degrees C).

¹ BPSK is available below 120 MHz but is unspecified.

Description

BPSK specifications are measured by viewing the modulated signal on a spectrum analyzer and measuring the difference between the unmodulated and modulated carrier levels (carrier null).

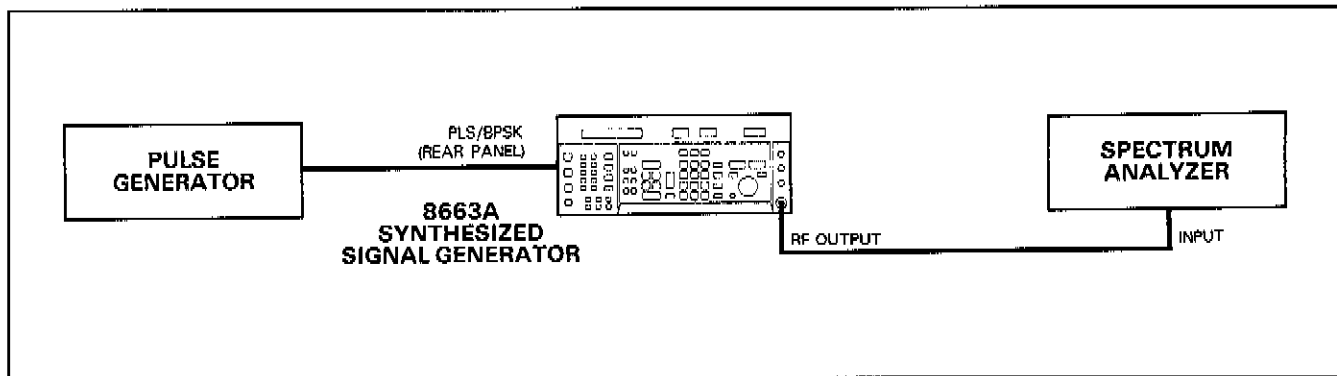

Figure 4-6. BPSK Test Setup

Equipment

Spectrum Analyzer HP 8565A
 Pulse Generator HP 8111A

Procedure

1. Connect the equipment as shown in Figure 4-6.
2. Set the pulse generator to produce a 50% duty cycle square wave at a 100 kHz rate. Set the pulse amplitude and offset controls to produce a 0 to +3.5V pulse.
3. Set the Generator's output frequency to 150.0 MHz and output amplitude to 0 dBm. Turn all modulation off. Tune the signal on the spectrum analyzer using 2 MHz/division frequency span. Set the reference level of the spectrum analyzer to the unmodulated signal amplitude.

- Turn on the Generator's BPSK modulation. The carrier level should fall and sidebands should appear. Measure how many dB the carrier is below the reference level. Record this value in the table provided.

Generator Frequency	Modulation Rate (kHz)	Results (dBc)	
		Actual	Specification
150	100	_____	> -20
300	100	_____	> -20
600	100	_____	> -20
250*	100	_____	> -17
2500*	100	_____	> -17

* Generator must have Option 002 (phase modulation) to produce BPSK at these frequencies.

- Perform steps 3 and 4 for each frequency in the table. Set the pulse generator's frequency to the modulation rate shown in the table. Record the values and check that the carrier null is more than the specification.

PERFORMANCE TEST 6

LEVEL ACCURACY AND FLATNESS TEST

Specification

Electrical Characteristics	Performance Limits	Conditions
Output Range	+16 to -129.9 dBm (1.41V to 0.072 μ V into 50 ohms)	
Resolution	0.1 dB	
Absolute Level Accuracy ^{1,2}	± 1.0 dB ± 3.0 dB	+16 to -120 dBm -120 dB and below
Flatness	± 1.0 dB ± 3.0 dB	+16 to -120 dBm -120 dBm and below
Flatness in Sweep Mode (+16 to -119.9 dBm)	± 1.1 dB ± 1.5 dB	0.1 to 1280 MHz 0.1 to 2560 MHz

¹ Includes flatness, attenuator error, detector error and measurement uncertainty.

² Level correction can be defeated via a special keyboard function.

Description

Level accuracy and flatness are checked at levels that can be read by a power meter.

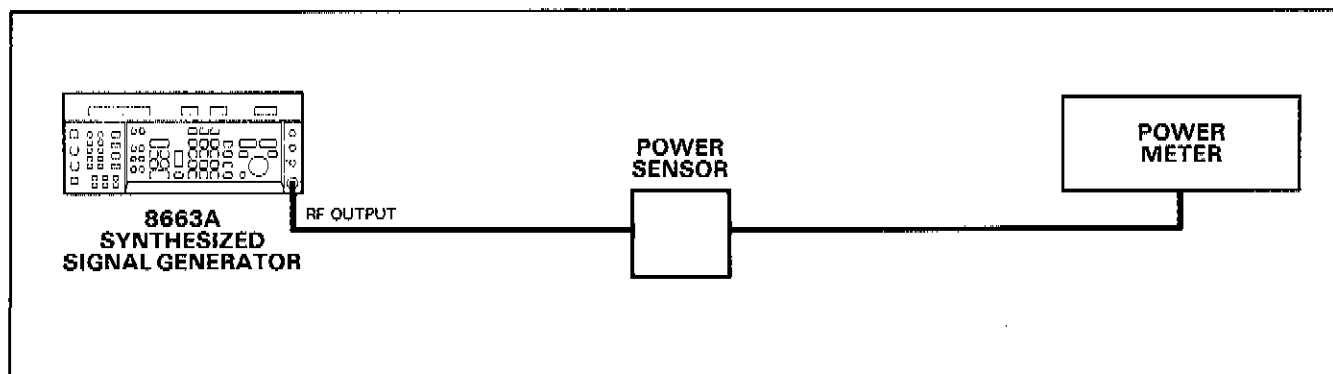

Figure 4-7. Level Accuracy and Flatness Test Setup

Equipment

Power Meter and Sensor HP 436A with 8482A

Procedure

1. Connect the power sensor to the Generator as shown in Figure 4-7, and zero the power meter.
2. Set the Generator's frequency to 10 MHz and frequency increment to 100 MHz. Set the output amplitude to +16 dBm.
3. Measure the power level. Then use the front panel keys to change frequency in the indicated increments. The power level must be $+16.0 \pm 1.0$ dBm.

Level Accuracy and Flatness Test (MHz)	Results (dBm)		
	Min	Actual	Max
+16 dBm:			
10	+15.0	_____	+17.0
110	+15.0	_____	+17.0
150	+15.0	_____	+17.0
310	+15.0	_____	+17.0
320	+15.0	_____	+17.0
410	+15.0	_____	+17.0
510	+15.0	_____	+17.0
610	+15.0	_____	+17.0
640	+15.0	_____	+17.0
910	+15.0	_____	+17.0
1210	+15.0	_____	+17.0
1280	+15.0	_____	+17.0
2010	+15.0	_____	+17.0
2510	+15.0	_____	+17.0

4. Repeat step 3 with the output amplitude set to +3.0, -3.0, and -12.0 dBm. All readings must be the specified value ± 1.0 dB.

Level Accuracy and Flatness Test (MHz)	Results (dBm)		
	Min	Actual	Max
+3.0 dBm:			
10	+2.0	_____	+4.0
110	+2.0	_____	+4.0
150	+2.0	_____	+4.0
310	+2.0	_____	+4.0
320	+2.0	_____	+4.0
410	+2.0	_____	+4.0
510	+2.0	_____	+4.0
610	+2.0	_____	+4.0
640	+2.0	_____	+4.0
910	+2.0	_____	+4.0
1210	+2.0	_____	+4.0
1280	+2.0	_____	+4.0
2010	+2.0	_____	+4.0
2510	+2.0	_____	+4.0

Level Accuracy and Flatness Test (MHz)	Results (dBm)		
	Min	Actual	Max
-3.0 dBm:			
10	-4.0	_____	-2.0
110	-4.0	_____	-2.0
150	-4.0	_____	-2.0
310	-4.0	_____	-2.0
320	-4.0	_____	-2.0
410	-4.0	_____	-2.0
510	-4.0	_____	-2.0
610	-4.0	_____	-2.0
640	-4.0	_____	-2.0
910	-4.0	_____	-2.0
1210	-4.0	_____	-2.0
1280	-4.0	_____	-2.0
2010	-4.0	_____	-2.0
2510	-4.0	_____	-2.0
-12.0 dBm:			
10	-13.0	_____	-11.0
110	-13.0	_____	-11.0
150	-13.0	_____	-11.0
310	-13.0	_____	-11.0
320	-13.0	_____	-11.0
410	-13.0	_____	-11.0
510	-13.0	_____	-11.0
610	-13.0	_____	-11.0
640	-13.0	_____	-11.0
910	-13.0	_____	-11.0
1210	-13.0	_____	-11.0
1280	-13.0	_____	-11.0
2010	-13.0	_____	-11.0
2510	-13.0	_____	-11.0

NOTE

This test, together with the "Operation Verification", checks the output specifications, the amplitude correction feature, and the operation of the output attenuator. If it is necessary to test the Generator at specific lower levels, use a power sensor with a lower range (the HP Model 8484A has a range of -20 to -60 dBm), or perform the test in paragraph 4-11 for levels below -60 dBm.

PERFORMANCE TEST 7

LEVEL ACCURACY TEST (OPTIONAL - LOW LEVEL)

Specification

Electrical Characteristics	Performance Limits	Conditions
Output Range	+16 to -129.9 dBm (1.41V to 0.072 uV into 50 ohms)	
Resolution	0.1 dB	
Absolute Level Accuracy ^{1,2}	± 1.0 dB ± 3.0 dB	+16 to -119.9 dBm -120 dB and below
Flatness	± 1.0 dB ± 3.0 dB	+16 to -119.9 dBm -120 dBm and below
Flatness in Sweep Mode (+16 to -119.9 dBm)	± 1.1 dB ± 1.5 dB	0.1 to 1280 MHz 0.1 to 2560 MHz
¹ Includes flatness, attenuator error, detector error and measurement uncertainty. ² Level correction can be defeated via a special keyboard function.		

Description

This test is an optional addition to the test in paragraph 4-10. This test should be performed only if it is necessary to check specific levels below -60 dBm.

Levels below -60 dBm cannot be measured directly with a power meter. To measure these low levels the Generator's output is read by a power meter at a level within its range. An accurately known attenuator is then inserted in series with the generator's output and the output of the attenuator is used to set a reference on the spectrum analyzer. The attenuator is removed and the Generator's level is set to the reference value on the spectrum analyzer and the actual value is calculated.

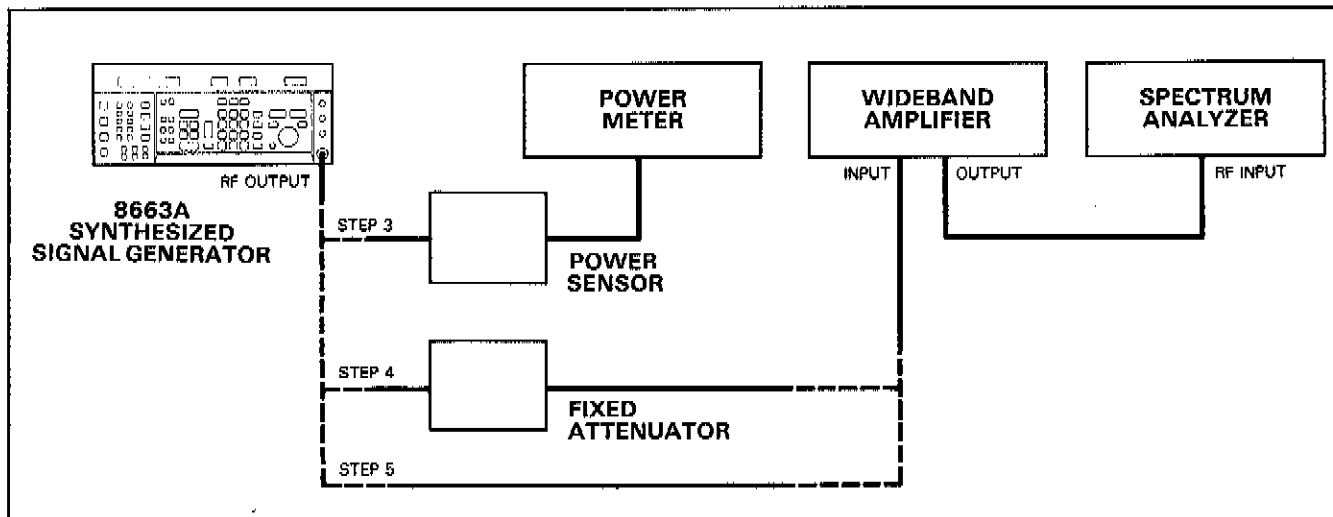

Figure 4-8. Level Accuracy Test Setup (Optional - Low Level)

Equipment

Power Meter and Sensor	HP 436A with 8484A
Spectrum Analyzer	HP 8565A
Wideband Amplifier	HP 8447D Option 010
RF Cable	HP 11500B
Fixed Attenuator	HP 8491A

Procedure

1. Connect the instruments as shown in Figure 4-8.
2. Select a fixed value attenuator that when subtracted from the amplitude to be tested gives a value between -20 and -60 dBm. For example, to test -100 dBm, choose an attenuation between 40 and 80 dB. The exact value of the attenuator at the frequency being tested must be known.
3. Set the Generator's output level higher than the amplitude being tested by the value of the attenuator. Measure the Generator's output with the power meter and record the value here.

_____ dBm

4. Connect the attenuator to the Generator's output and to the spectrum analyzer's input through the wideband amplifier. View the signal on the spectrum analyzer and set the reference level to one division above the signal in the 2 dB log amplitude mode. Only use well shielded RF cables or leakage will affect the accuracy of the results.
5. Set the Generator's output amplitude to the value being tested (level A) and remove the attenuator. View the signal on the spectrum analyzer and determine the difference from the signal viewed in step.

6. The actual output level is calculated as follows:

$$\begin{array}{rcl}
 \text{_____} & \text{power meter reading (step 3)} & \\
 + \text{_____} & \text{exact value of attenuator} & \\
 & \text{(at frequency MHz)} & \\
 + \text{_____} & \text{difference observed (steps 4 and 5)} & \\
 = \text{_____} & \text{actual output level where the indicated value} & \\
 & \text{(level A) is _____ dBm.} &
 \end{array}$$

Actual Output Level	Results		
	Min	Actual	Max
-60 to -119.9 dBm	A-1.0 dBm	_____	A+1.0 dBm
-120 dBm and below	A-3.0 dBm	_____	A+3.0 dBm

Example:

$$\begin{aligned}
 & - 40.7 \text{ dBm} \quad (\text{step 3}) \\
 + & \underline{- 60.3 \text{ dB}} \quad (\text{attenuator value step 2}) \\
 & -101.0 \text{ dBm} \\
 + & \underline{- 3.0 \text{ dB}} \quad (\text{difference level steps 4 and 5}) \\
 = & -104.0 \text{ dBm} \quad (\text{level A})
 \end{aligned}$$

PERFORMANCE TEST 8

SSB PHASE NOISE TEST

Specification

Electrical Characteristics	Performance Limits	Conditions
Spectral Purity Residual SSB Phase Noise in 1 Hz Bandwidth	-100 dBc -112 dBc -121 dBc -131 dBc -132 dBc	320 to 640 MHz; CW and AM mode. 10 Hz offset from carrier 100 Hz offset from carrier 1000 Hz offset from carrier 10 kHz offset from carrier 100 kHz offset from carrier
SSB Broadband Noise Floor in 1 Hz Bandwidth	-145 dBc	>+10 dBm output level; ΦM off; 120 to 640 MHz; 3 MHz offset from carrier

Description

SSB phase noise is measured by mixing the RF output of the Signal Generator and its 10 MHz reference signal in a double balanced mixer to eliminate the carrier and translate the noise spectrum down to a low frequency where it can be viewed on a high resolution spectrum analyzer. The 10 MHz reference output from the Signal Generator's rear panel is used as the LO input for the mixer. The Signal Generator's output is set to 10 MHz and is used as the RF input to the mixer. The output of the mixer is viewed on a spectrum analyzer at 10 kHz and 100 kHz.

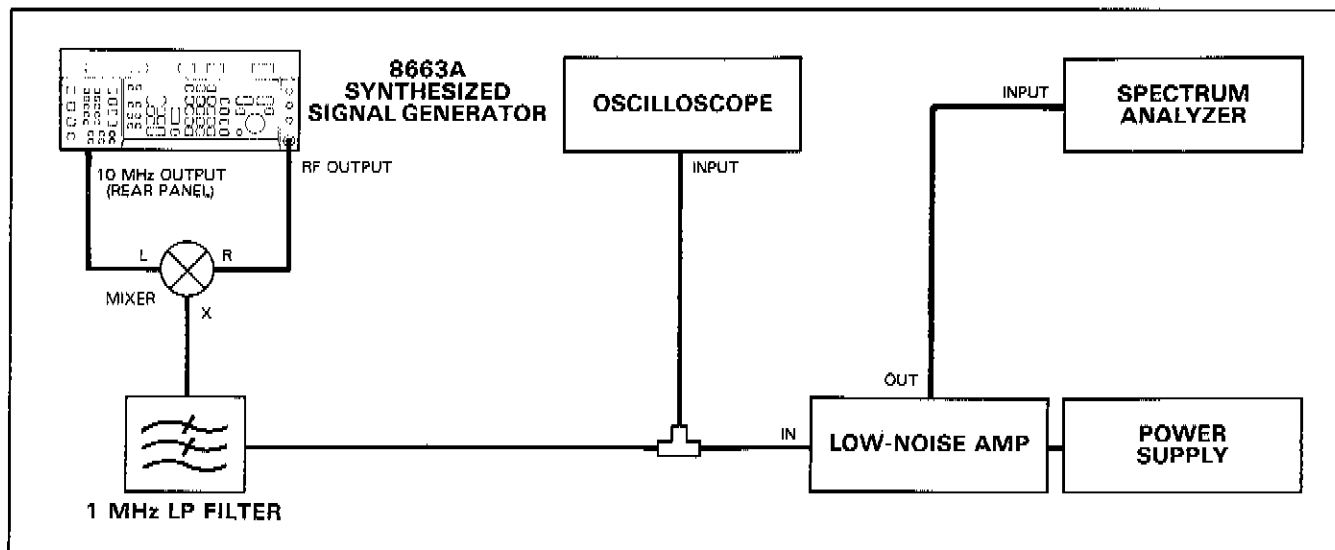

Figure 4-9. SSB Phase Noise Test Setup

NOTE

This test is a good overall check of the phase noise performance of the Generator. However, if it is necessary to check phase noise at a specific output frequency, perform Performance Test 9.

Equipment

Mixer.....	HP 10514A
1 MHz Low Pass Filter.....	(See Figure 1-2)
Low-Noise Amplifier.....	HP 08640-60506 With Power Supply HP 6002A
Spectrum Analyzer, Low Frequency.....	HP 8556A/8552B/141T
Oscilloscope.....	HP 1741A

Procedure

1. Connect instruments as shown in Figure 4-9.

NOTE

Values in parenthesis are to be used the second time through the procedure to measure phase noise 100 kHz from the carrier.

2. Set the Generator to 10.010 (10.10) MHz and -50 dBm amplitude. Set the spectrum analyzer to 40 dB of input attenuation and view the 10 (100) kHz signal at any calibrated combination of resolution and bandwidth (no video filtering).
3. Adjust the reference level on the spectrum analyzer so the signal is 4 dB below the reference level. This compensates for the noise contribution of the LO signal.
4. Set the Generator to 10.0 MHz and 0 dBm amplitude. Set the spectrum analyzer to 0 value input attenuation.
5. Set the Generator's frequency increment to 0.1 Hz. Press the INCREMENT (up) key and view the signal in the dc coupled mode on the oscilloscope. The signal should be slowly moving around ground level (0.1 Hz sine wave). Stop the signal at ground level by pushing the Generator's INCREMENT (down) key. This sets the two input signals to the mixer in phase quadrature (90 degrees out of phase).
6. Set the bandwidth of the spectrum analyzer to 10 Hz, scan width to the minimum, and sweep so that the display is calibrated. View the signal and note how much the signal is below the top graticule of the display.
7. The actual phase noise is calculated from the reading obtained in step 6 by applying the following corrections:
 - a. Add -50 dB to correct for the change in the Generator's attenuator.
 - b. Add -40 dB to correct for the change in the spectrum analyzer's attenuator.
 - c. Add -10 dB because the measurement was made in a 10 Hz bandwidth but phase noise is specified in a 1 Hz bandwidth.
8. Phase noise should be -131 dB or lower.

-131 dBc _____
9. Repeat steps 2 through 7 using the values in parenthesis and measure the phase noise 100 kHz away from the carrier. Phase noise should be -132 dB or lower.

-132 dBc _____

PERFORMANCE TEST 9

SSB PHASE NOISE TEST (OPTIONAL)

Specification

Electrical Characteristics	Performance Limits	Conditions
Spectral Purity Residual SSB Phase Noise in 1 Hz Bandwidth	-100 dBc -112 dBc -121 dBc -131 dBc -132 dBc	320 to 640 MHz; CW and AM mode. 10 Hz offset from carrier 100 Hz offset from carrier 1000 Hz offset from carrier 10 kHz offset from carrier 100 kHz offset from carrier
SSB Broadband Noise Floor in 1 Hz Bandwidth	-145 dBc	> +10 dBm output level; FM OFF 120 to 640 MHz; 3 MHz offset from carrier

Description

This test is an optional alternative to Performance Test 8. This test should be performed only if it is necessary to check phase noise at frequencies other than 10 MHz.

A reference signal generator and a double-balanced mixer are used to translate the noise spectrum to a lower frequency so that it can be viewed on a high resolution spectrum analyzer.

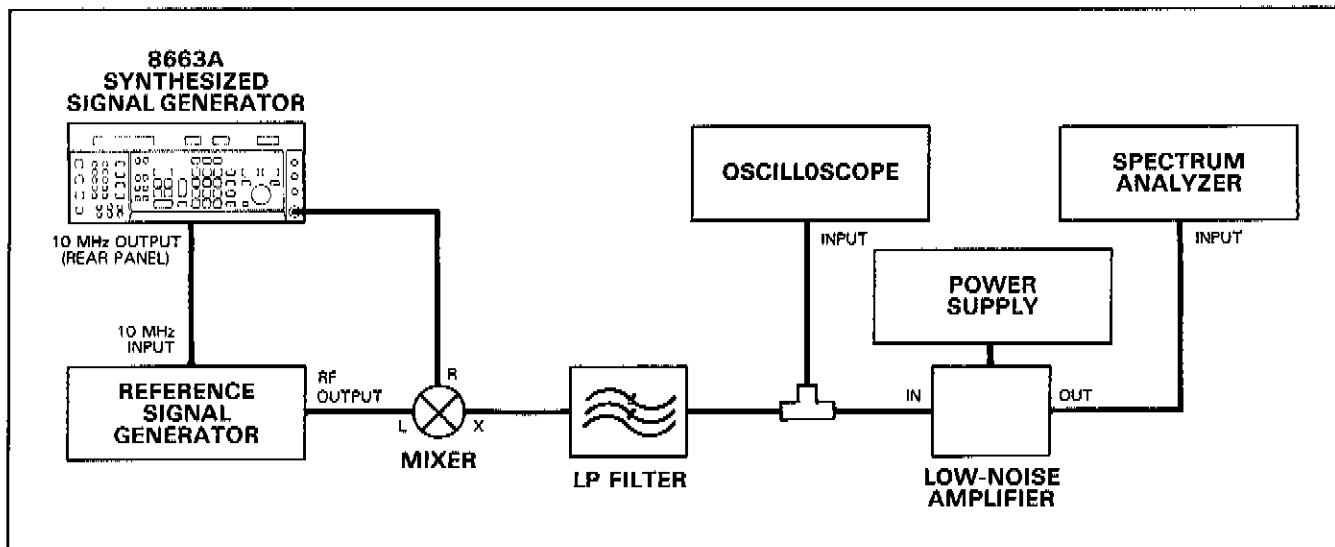

Figure 4-10. SSB Phase Noise Test Setup (Optional)

NOTE

This test measures the total SSB phase noise of both Generators. Therefore, the reference generator must have SSB phase noise that is less than or equal to the specification for the Generator under test.

Equipment

Mixer	HP 10514A or Watkins-Johnson M1J
Low-Pass Filter	(see Figure 1-2)
Low-Noise AMP	HP 08640-60506 (with Power Supply HP 6002A)
Spectrum Analyzer, Low Frequency	HP 8556A/8552B/141T
Oscilloscope	HP 1741A
Signal Generator	HP 8663A

Procedure

1. Connect the instruments as shown in Figure 4-10. The LP filter should have a bandwidth more than 10 times greater than the offset frequency where phase noise will be measured.

NOTE

The following symbols are used in the procedure:

f_{RF} = the RF output frequency where SSB phase noise will be checked.

f_{OFF} = the frequency offset from f_{RF} where SSB phase noise will be checked.

2. Set the reference generator's frequency to f_{RF} and the output level to +13 dBm. Set the Signal Generator under test to $f_{RF} + f_{OFF}$ and the output level to -50 dBm.
3. Set the spectrum analyzer to 40 dB of input attenuation and view the signal at f_{RF} with any calibrated combination of resolution and bandwidth (no video filtering).
4. Set the reference level of the spectrum analyzer so the signal is 7 dB below the reference level. This compensates for the noise contribution of the LO signal and the effect of the spectrum analyzer when measuring noise.
5. Set the Signal Generator under test to f_{RF} and 0 dBm output level. Set the spectrum analyzer to 0 input attenuation.
6. Set the frequency increment for the Generator under test to 0.1 Hz. Press the INCREMENT (up) key and view the signal in the dc coupled mode on the oscilloscope. The signal should be slowly moving around ground level (0.1 Hz sine wave). Stop the signal at ground level by pushing the INCREMENT (down) key. This sets the two input signals to the mixer in phase quadrature (90 degrees out of phase).
7. Set the bandwidth of the spectrum analyzer to 10 Hz, span width to the minimum, and sweep so that the display is calibrated. View the signal and note how much the signal is below the reference level.
8. The actual phase noise level is calculated from the level viewed on the spectrum analyzer by applying the following correction:
 - a. Add -50 dB to correct for the change in the attenuator in the Generator under test.
 - b. Add -40 dB to correct for the change in the spectrum analyzer's attenuator
 - c. Add -10 dB because the measurement was made in a 10 Hz bandwidth but phase noise is specified in a 1 Hz bandwidth.

9. Measured phase noise should be at or below the specified value.

$f_{RF} =$ _____ (320-640 MHz)

Offset Frequency f_{OFF}	SSB Phase Noise	
	Min.	Actual
0 Hz	-100 dBc	_____
100 Hz	-112 dBc	_____
1 kHz	-121 dBc	_____
10 kHz	-131 dBc	_____
100 kHz	-132 dBc	_____

PERFORMANCE TEST 10

HARMONICS AND SPURIOUS TESTS

Specification

Electrical Characteristics	Performance Limits	Conditions
Spurious Output Signals (non-harmonically related) ^{1,2}	-90 dBc -100 dBc -96 dBc -90 dBc -84 dBc -78 dBc	0.01 to 120 MHz 120 to 160 MHz 160 to 320 MHz 320 to 640 MHz 640 to 1280 MHz 1280 to 2560 MHz
Spurious Output Signals (sub-harmonically related) ³	none -70 dBc -40 dBc	0.1 to 640 MHz 640 to 1280 MHz 1280 to 2560 MHz
Spurious Output Signals [Power line (60 Hz) related or microphonically generated (within 300 Hz from carrier)] ⁴	-90 dBc -85 dBc -80 dBc -75 dBc -70 dBc -65 dBc	0.01 to 120 MHz 120 to 160 MHz 160 to 320 MHz 320 to 640 MHz 640 to 1280 MHz 1280 to 2560 MHz
Harmonics	< -30 dBc ≤ +13 dBm output < -25 dBc +13 dBm to +16 dBm output	0.1 to 1280 MHz 1280 to 2560 MHz

¹ In remote mode, it is possible to have spurious signals related to the microprocessor clock spaced 3 MHz apart, at levels typically less than -145 dBm.

² Spurious signals can be 3 dB if the FM mode is enabled with dc-coupling of a dc level at either of the modulation inputs.

³ Subharmonically related signals are $f/2$, $3f/2$, etc.

⁴ At 50 Hz line frequency, power line or microphonically related spurious signals may be up to 3 dB higher and appear at offsets as high as 1 kHz from the carrier.

Description

The RF output of the Signal Generator is viewed on a spectrum analyzer. The Generator's frequency is set to values where harmonic and spurious performance problems are most likely to be observed.

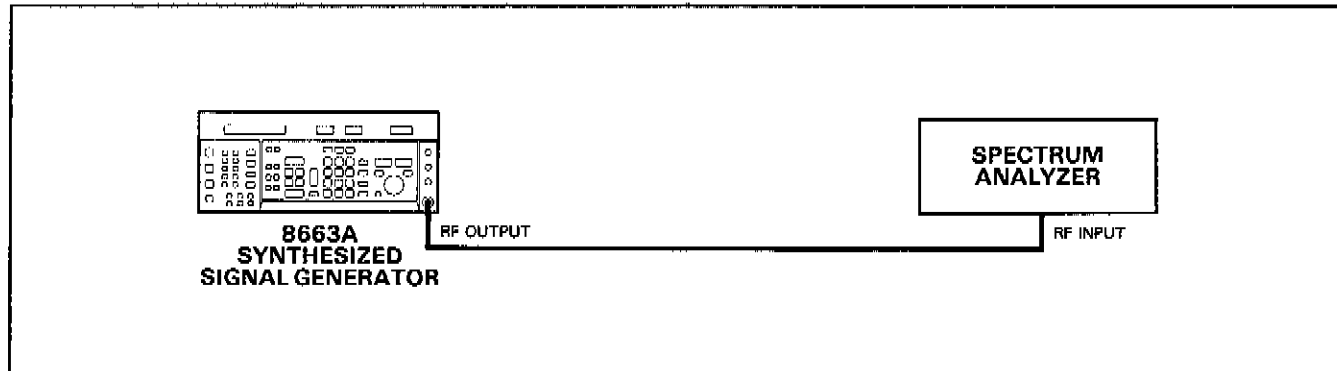

Figure 4-11. Harmonics and Spurious Test Setup

Equipment

Spectrum Analyzer, RF..... HP 8565A

Procedure

1. Connect the RF Output of the Generator to the input of the spectrum analyzer.

Harmonics

2. Set the Generator's amplitude to +13 dBm and frequency to the values in the first column of the following table. Set the spectrum analyzer to the frequencies in the second column to view the second harmonic. The second harmonic should be more than 30 dB below the fundamental.

Frequency (MHz)	2nd Harmonic (MHz)	Results	
		Min	Actual
90.0	180.0	-30 dBc	_____
159.0	318.0	-30 dBc	_____
319.0	638.0	-30 dBc	_____
320.0	640.0	-30 dBc	_____
370.0	740.0	-30 dBc	_____
450.0	900.0	-30 dBc	_____
640.0	1280.0	-30 dBc	_____
745.0	1490.0	-30 dBc	_____

Spurious

3. If the Generator failed the preceding test, perform the "Output Amplifier Power Amp Adjustment" in Section 5.
4. Set the Generator's frequency to 320.0 MHz and amplitude to 0.0 dBm. Set the spectrum analyzer's input attenuator to the minimum attenuation allowable with a 0 dBm input signal. Adjust the tuning so the signal is centered on the second vertical graticule line from the left of the screen. Use 50 kHz resolution and 1 kHz bandwidth settings. Set the reference level to -40 dBm. The display should be as shown in Figure 4-12.

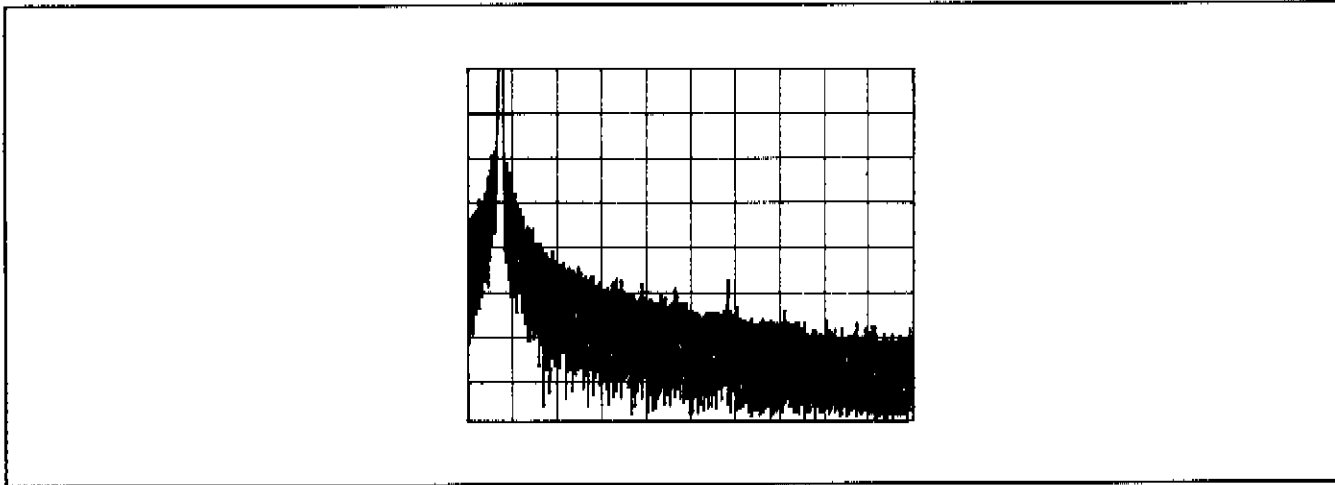

Figure 4-12. Spurious Test Spectrum Analyzer Display (321.8 MHz, 50 kHz/Division, 1 kHz Bandwidth)

5. Set the Generator frequency to the values shown in the following table. At each frequency setting look at the spectrum from 100 to 350 kHz above the signal. All spurious signals must be below the level stated in the table. If the noise level is too high at any point, reduce bandwidth or add video filtering, but the sweep speed must be slowed to keep the amplitude calibrated.

NOTE

In order to obtain maximum sensitivity, this test requires driving the input mixer of the spectrum analyzer above its optimum level. This could cause the generation of spurious signals in the spectrum analyzer. If a spurious signal is observed, change the Generator's frequency. If the spurious disappears, it most likely is from the Generator. If the spurious moves with the Generator's signal, it is probably generated in the spectrum analyzer.

Frequency (MHz)	Results	
	Min	Actual
320.000 000	-90 dBc	_____
320.000 010	-90 dBc	_____
320.000 030	-90 dBc	_____
320.000 100	-90 dBc	_____
320.000 300	-90 dBc	_____
320.001 000	-90 dBc	_____
320.003 000	-90 dBc	_____
320.010 000	-90 dBc	_____
320.030 000	-90 dBc	_____
320.100 000	-90 dBc	_____
329.999 990	-90 dBc	_____
329.999 970	-90 dBc	_____
329.999 900	-90 dBc	_____
329.999 700	-90 dBc	_____
329.999 000	-90 dBc	_____
329.997 000	-90 dBc	_____
329.970 000	-90 dBc	_____
329.900 000	-90 dBc	_____
103.980 000	-90 dBc	_____
640.000 000	-84 dBc	_____
1280.000 000	-78 dBc	_____

PERFORMANCE TEST 11

INTERNAL TIME BASE AGING RATE TEST

Specification

Electrical Characteristics	Performance Limits	Conditions
Internal Reference Oscillator ¹		
Frequency	10 MHz	
Aging Rate	5×10^{-10} /day	After ten day warm-up (typically 24 hrs in normal operating environment)

¹ The internal reference oscillator is kept at operating temperature in STANDBY mode with the instrument connected to Mains power.

Description

The reference signal from the Signal Generator (10 MHz OUTPUT) is connected to the oscilloscope's vertical input. A frequency standard (with long-term stability greater than 1×10^{-10}) is connected to the trigger input. The time required for a specific phase change is measured immediately and after a period of time. The aging rate is inversely proportional to the absolute value of the difference in the measured times.

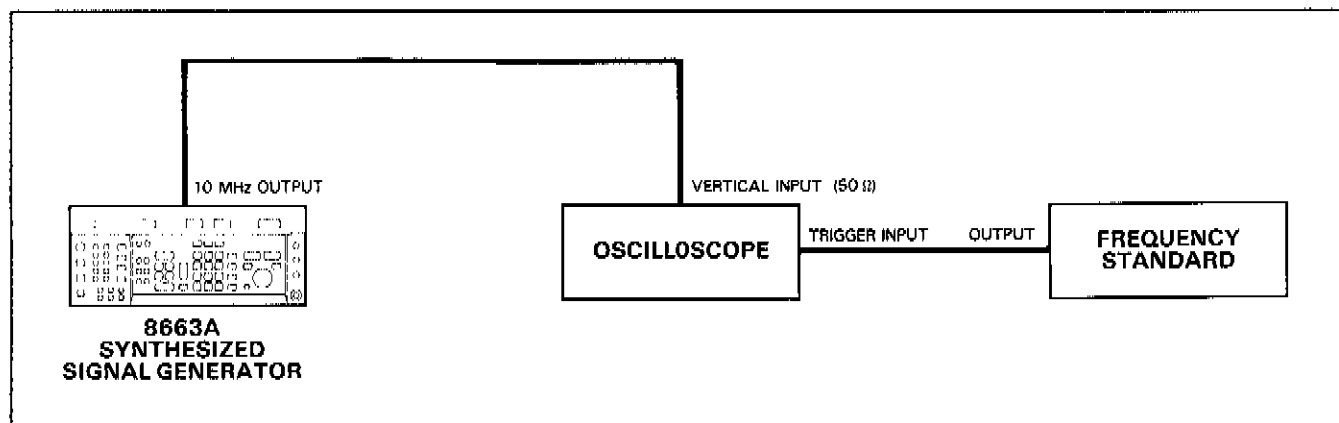

Figure 4-13. Internal Time Base Aging Rate Test Setup

Equipment

Frequency Standard HP 5065A
 Oscilloscope HP 1741A

NOTE

Be sure the Signal Generator has had 10 days to warm up before beginning the test. If the Signal Generator was disconnected from the power line for less than 24 hours, only a 24 hour warm-up is needed.

WARNING

Be careful working near the fan at the back of the Signal Generator. Long hair can be drawn into the fan causing personal injury.

Procedure

1. Set the rear panel REFERENCE switch to INT.
2. Connect the instruments shown in Figure 4-13.
3. Adjust the oscilloscope's controls for a stable display of the 10 MHz output.
4. Measure the time required for a phase change of 360 degrees. Record the time (T_1) in seconds.

$$T_1 = \text{_____ s}$$

5. Wait for a period of time (from 3 to 24 hours) and re-measure the phase change time (T_2). Record the period of time between measurements (T_3) in hours.

$$T_2 = \text{_____ s}$$

$$T_3 = \text{_____ h}$$

6. Calculate the aging rate from the following equation:

$$\text{Aging Rate} = \left| \left(\frac{1 \text{ cycle}}{f} \right) \left(\frac{1}{T_1} - \frac{1}{T_2} \right) \left(\frac{T}{T_3} \right) \right|$$

where:

1 cycle = the phase change reference for the time measurement (in this case 360 degrees)

f = Signal Generator's reference output frequency (10 MHz)

T = specified time for aging rate (24h)

T1 = initial time measurement(s) for a 360 degree (1 cycle) change

T2 = final time measurement(s) for a 360 degree (1 cycle) change

T3 = time between measurement (h)

for example:

if $T_1 = 351\text{s}$

$T_2 = 349\text{s}$

$T_3 = 3\text{h}$

then:

$$\text{Aging Rate} = \left| \left(\frac{1 \text{ cycle}}{10 \text{ MHz}} \right) \left(\frac{1}{351\text{s}} - \frac{1}{349\text{s}} \right) \left(\frac{24\text{h}}{3\text{h}} \right) \right|$$

$$\text{Aging Rate} = 1.306 \times 10^{-11}$$

- Record the aging rate.

Aging Rate _____ 5×10^{-10} /day

NOTE

If the absolute frequencies of the frequency standard and the Signal Generator's reference oscillator are extremely close, the measurement time in steps 4 and 5 (T_1 and T_2) can be reduced by measuring the time required for a phase change of something less than 360 degrees. Change 1 cycle in the formula (e.g., 180 degrees = 1/2 cycle, 90 degrees = 1/4 cycle).

- If the rate aging is not within the required tolerance, check the power supplies before replacing A8A3. Be sure sufficient warm-up time has been allowed (may require up to 10 days).

1-20-1995 2:14AM

FROM

P. 2

Performance Tests

Op/Cal Manual, 08663-90069

Model 8663A

Performance Test 12

THIS PAGE UPDATED
8-1-99

ABSOLUTE SSB PHASE NOISE ON REAR PANEL 640 MHz OUTPUT (OPTION 003 ONLY)

Specification

Electrical Characteristics	Performance Limits	Conditions
Spectral Purity Absolute SSB Phase Noise on rear panel 640 MHz output	-54 dBc -84 dBc -104 dBc -121 dBc -145 dBc -157 dBc	1 Hz measurement Bandwidth. Offset from carrier 1 Hz 10 Hz 100 Hz 1 kHz 10 kHz 100 kHz
Output Level of rear panel 640 MHz output	+1 to +4 dBm	

Description

The absolute SSB phase noise is measured by comparing the rear panel 640 MHz output signal to the rear panel 640 MHz output signal of another signal generator with known good phase noise. The phase detector method of phase noise measurement is used and the results are measured with a spectrum analyzer. The output level of the 640 MHz signal is also verified.

NOTE

Only instruments with serial number 2411A and above have the rear panel 640 MHz output and EFC input required to perform this test. This rear panel input and output was available on earlier serial number instruments if options H12 and H03 were ordered.

A better method of measuring this specification is to use the HP 3018A Phase Noise Measurement System. This system can make the measurement quickly and accurately. The procedure specified in this performance test is accurate but very time consuming.

REV 12 SEPT 90

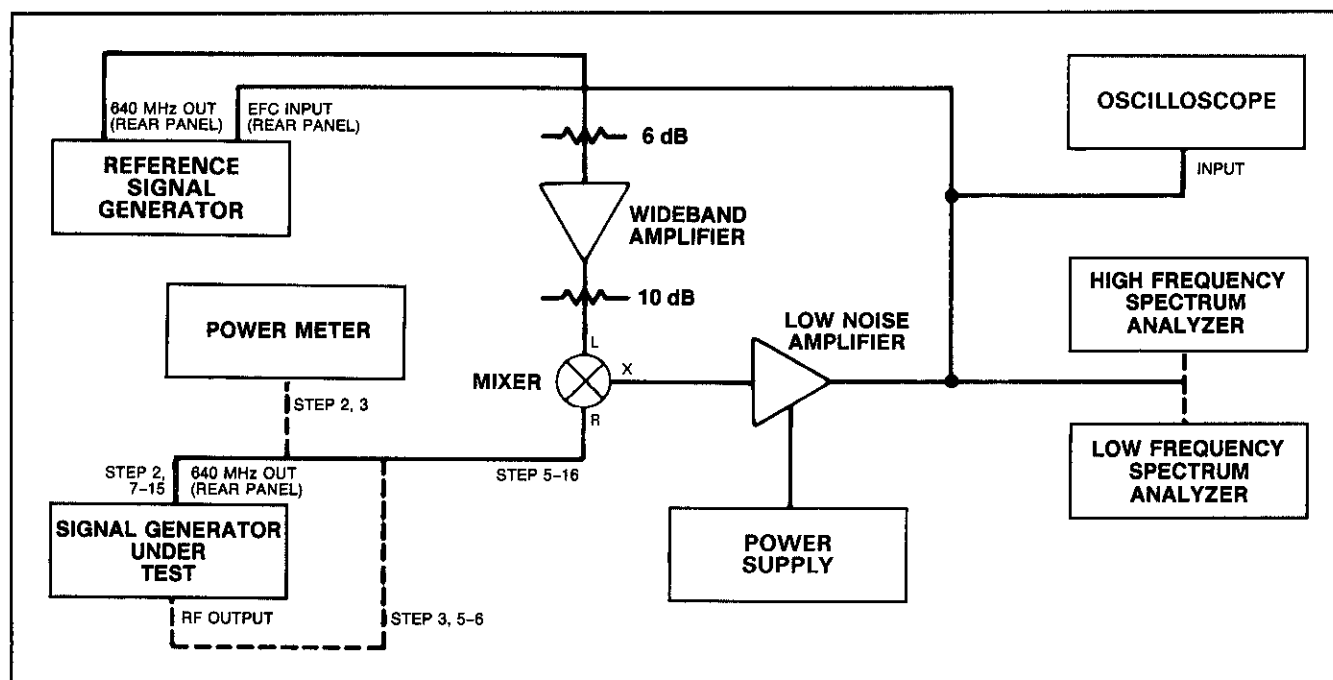

Figure 4-14. Absolute SSB Phase Noise of rear Panel 640 MHz Output (Option 003 Only) Test Setup

Equipment

Mixer.....	Watkins-Johnson M1J
Low Noise Amplifier	HP 08640-60506 (with HP 6002A power supply)
Oscilloscope	HP 1741A
Spectrum Analyzer (Low frequency)	HP 3582A
Spectrum Analyzer (High frequency)	HP 8566A or HP 8568B
Signal Generator (Reference)	HP 8662A Option 003
Wide Band Amplifier	HP 8447E
Attenuators, Coaxial Fixed	HP 8491A series
Power Meter	HP 436A with HP 8481A Power Sensor

Procedure

1. Connect the equipment as shown in Figure 4-14. Both the Reference Signal Generator and Signal Generator Under Test must have their Reference Oscillator switches set to INT. The signal level into the L input of the mixer should be in the range, +7 to +10 dBm. Change the value of the pads, if necessary, to obtain this output level.
2. Use the power meter to measure the RF level of the rear panel 640 MHz output signal of the Signal Generator Under Test. The level must be greater than +1.0 dBm. Record the measured level.
 Rear panel 640 MHz output level _____ dBm
3. Connect the power meter to the main RF output of the Signal Generator Under Test. Set the frequency of the generator to 640.0 MHz and set the amplitude to whatever setting gives the closest power meter reading to the value measured in step 2, above.
4. Set the Amplitude increment value of the Signal Generator Under Test to 50 dB. Press the Increment down arrow key thus reducing the amplitude by 50 dB.

Calibration

NOTE

This calibration must be performed once with the high frequency spectrum analyzer and twice with the low frequency spectrum analyzer. Thus, there are three values specified for every frequency setting in steps 5 and 6. Use the first setting given with the high frequency spectrum analyzer and the other values (in parenthesis and brackets) with the low frequency spectrum analyzer.

5. Connect a cable from the RF port of the mixer to the RF output connector of the Signal Generator Under Test. Set the output frequency of this generator to 640.01 (640.000 1) [640.000 01] MHz. This will produce a 10 kHz (100 Hz) [10 Hz] signal out of the mixer which is used to calibrate the spectrum analyzer.
6. Tune the spectrum analyzer to 10 kHz (100 Hz) [10 Hz] and set the reference level of the spectrum analyzer to the level of the signal at 10 kHz (100 Hz) [10 Hz].

Set Quadrature

7. Connect a cable from the RF port of the mixer to the rear panel 640 MHz output of the Signal Generator Under Test.
8. Set the oscilloscope to dc coupled input and 0.1 volts/ division vertical resolution. Set sweep speed to 0.2 mSEC/ division although sweep speed will not affect the measurement. Adjust the vertical position control so ground level is at the center line of the display.
9. The signal displayed on the oscilloscope should be a slowly varying signal. If the signal is a dc level, adjust the FINE FREQUENCY ADJUST on the rear panel of the Reference Signal Generator until the signal begins to vary. If necessary, change the vertical resolution so the oscilloscope displays the peaks of the waveform. Note the peak amplitude (Vp) of the signal and record here.

Vp _____

10. Slowly adjust the FINE FREQUENCY ADJUST on the rear panel of the Reference Signal Generator while watching the oscilloscope display. Turn the adjustment in the direction which decreases the rate of change of the signal. Continue the adjustment until the signal becomes a dc level which indicates the signal generators are phase locked together. The dc level of the signal (+ or -) must be less than 30% of Vp measured in step 9.

NOTE

This is a very difficult adjustment to make. It is very easy to overshoot the point where the signal becomes dc in which case the rate of change will begin to increase. It is best to let both signal generators set with the line cords connected for at least 24 hours and with the LINE switch to ON for 1 hour before making this measurement. Once set the dc level should be stable for at least 15 minutes which is long enough to make the measurement. If the dc level drifts too much, the problem could be that the reference oscillator does not meet its long term stability specification. Perform the Internal Time Base Aging Test to check its stability.

Measurement

11. Set the spectrum analyzer to its noise measurement mode. In this mode the spectrum analyzer normalizes the measurement to a 1 Hz bandwidth and corrects the reading to compensate for the noise measurement properties of the analyzer.

12. Set the spectrum analyzer center frequency to the offset at which phase noise is to be measured. This is 10.0 kHz the first time through this procedure. Lower the video bandwidth or use trace averaging to reduce the ambiguity of reading the noise level. Also if there is a spurious signal at exactly 10.0 kHz, read the noise level on either side of the signal. Determine how far (-XX dB) the noise level is below the reference level. If the spectrum analyzer gives a marker level in absolute dBm, subtract the reference level from it to get the relative value. Record the value in the table that follows.
13. The following corrections must be applied to the value just measured to get the actual phase noise:
 - Add -50 dB because the reference level was calibrated with a signal 50 dB lower than the actual 640 MHz output.
 - Add -6 dB because the measured value is the double sideband value and the specification is the single sideband value.
 - Add -3 dB because the reference signal adds an equal amount of noise to the measured value.

Thus, the total correction is -59 dB.

14. Measure the phase noise at an offset of 100 kHz with the high frequency spectrum analyzer. Follow the instructions in steps 12 and 13. Record the measured values in the table that follows.
15. Replace the high frequency spectrum analyzer with the low frequency spectrum analyzer. The test set-up must be calibrated twice with the low frequency spectrum analyzer. Return to step 5 and restart the procedure there using the the settings in parenthesis, (). When the Measurement Section is reached, measure the phase noise at offsets of 100 Hz and 1 kHz. Record the measured values in the table that follows.
16. Return to step 5 and restart the procedure there using the settings in brackets, []. When the Measurement Section is reached, measure the phase noise at an offset of 10 Hz. Record the value in the table that follows.

NOTE

The phase noise at 1 Hz from the carrier is not measured by this procedure. The measurement at 10 Hz insures that the noise at 1 Hz is within specifications. The noise at 1 Hz could be measured by using a low-noise amplifier with dc coupling.

Offset	Measured Noise			Limit (dBc/Hz)
	Relative to Reference Level (dB/Hz)	Correction	Total (dBc/Hz)	
10 Hz	_____	-59 dB	_____	- 84
100 Hz	_____	-59 dB	_____	-104
1 kHz	_____	-59 dB	_____	-121
10 kHz	_____	-59 dB	_____	-145
100 kHz	_____	-59 dB	_____	-157

Performance Test Record

Performance Test 2

AM Indicator Accuracy

AM Indicated (%) For 100 MHz	Results		
	Min	Actual	Max
10	8.4	_____	11.6
30	27.2	_____	32.8
70	64.8	_____	75.2
90	83.6	_____	96.4

AM Indicated (%) For 500 MHz	Results		
	Min	Actual	Max
10	8.4	_____	11.6
30	27.2	_____	32.8
70	64.8	_____	75.2
90	83.6	_____	96.4

AM Indicated (%) For 1.0 GHz	Results		
	Min	Actual	Max
10	8.4	_____	11.6
30	27.2	_____	32.8
70	64.8	_____	75.2
90	83.6	_____	96.4

AM Indicated (%) For 1.3 GHz	Results		
	Min	Actual	Max
10	8.4	_____	11.6
30	27.2	_____	32.8
70	64.8	_____	75.2
90	83.6	_____	96.4

AM Indicated (%) For 100 MHz	Results		
	Min	Actual	Max
10	8.4	_____	11.6
30	27.2	_____	32.8
70	64.8	_____	75.2
90	83.6	_____	96.4

Performance Test 2 (con't)

Incidental Φ M

8663A Frequency	Modulation Analyzer Mode	Results	
		Actual	Max
600.0 MHz	Φ M	_____	0.15 rad
1000.0 MHz	Φ M	_____	0.1 rad

AM Distortion

AM Indicated (%) For 100 MHz	Results	
	Actual	Max
30	_____	2.0%
70	_____	3.0%
90	_____	4.0%

AM Indicated (%) For 600 MHz	Results	
	Actual	Max
30	_____	2.0%
70	_____	3.0%
90	_____	4.0%

AM Indicated (%) For 1.0 GHz	Results	
	Actual	Max
30	_____	2.0%
70	_____	3.0%
90	_____	4.0%

AM Indicated (%) For 1.3 GHz	Results	
	Actual	Max
30	_____	2.0%
70	_____	3.0%
90	_____	4.0%

Performance Test 2 (con't)

FM Indicator Accuracy

FM Indicated	Results		
	Min	Actual	Max
5.0 kHz	4.54 kHz	_____	5.46 kHz
30.0 kHz	27.29 kHz	_____	32.71 kHz
70.0 kHz	63.69 kHz	_____	76.31 kHz
100.0 kHz	90.99 kHz	_____	109.01 kHz

Incidental AM

Frequency Setting For 1.0 GHz	Results	
	Actual	Max
100.0 MHz	_____	.05%
1.0 GHz	_____	.05%
1.3 GHz	_____	.05%

Performance Test 3

Phase Modulation Accuracy

RF Frequency (MHz)	ΦM Setting (degrees)	Test Oscillator (kHz)	Results (degrees)		
			Max.	Actual	Min.
100	100	1	85.00	_____	115.00
150	25	10	21.25	_____	28.75
300	50	20	42.50	_____	57.50
500	100	20	85.00	_____	115.00
1000 ¹	200	20	170.00	_____	230.00
1300	400	20	340.00	_____	460.00

¹ At these settings the modulation analyzer may autorange to the highest phase modulation range which does not give enough output to drive the distortion analyzer. If the distortion analyzer reading is erratic, push the ΦM key on the modulation analyzer and it will set itself to the correct range.

Performance Test 3 (con't)

Phase Modulation Accuracy (con't)

RF Frequency (MHz)	Results (degrees)		
	Max.	Actual	Min.
500.0	73	_____	91
439.9	73	_____	91
449.9	73	_____	91
639.9	73	_____	91

RF Frequency (MHz)	ΦM Setting (degrees)	Results (degrees)		
		Max.	Actual	Min.
1000.0	138	116	_____	160
2000.0	332	281	_____	383

Performance Test 4

Rise Time / Fall Time

Generator Frequency	Leading Edge		Trailing Edge	
	Actual	Specification	Actual	Specification
500.0 MHz	_____	< 800 ns.	_____	< 800 ns.
1.0 GHz	_____	< 100 ns.	_____	< 100 ns.
2.0 GHz	_____	< 100 ns.	_____	< 100 ns.

On/Off Ratio

Generator Frequency	On/Off Ratio	
	Actual	Specification
100.0 MHz	_____	> 80
500.0 MHz	_____	> 80
1.0 GHz	_____	> 85
2.0 GHz	_____	> 85

Performance Test 5

BPSK Carrier Null

Generator Frequency	Modulation Rate (kHz)	Results (dBc)	
		Actual	Specification
150	100	_____	> -20
300	100	_____	> -20
600	100	_____	> -20
250*	100	_____	> -17
2500*	100	_____	> -17

* Generator must have Option 002 (phase modulation) to produce BPSK at these frequencies.

Performance Test 6

Level Accuracy and Flatness Test

Level Accuracy and Flatness Test (MHz)	Results (dBm)		
	Min	Actual	Max
+16 dBm:			
10	+15.0	_____	+17.0
110	+15.0	_____	+17.0
150	+15.0	_____	+17.0
310	+15.0	_____	+17.0
320	+15.0	_____	+17.0
410	+15.0	_____	+17.0
510	+15.0	_____	+17.0
610	+15.0	_____	+17.0
640	+15.0	_____	+17.0
910	+15.0	_____	+17.0
1210	+15.0	_____	+17.0
1280	+15.0	_____	+17.0
2010	+15.0	_____	+17.0
2510	+15.0	_____	+17.0

Performance Test 6 (con't)

Level Accuracy and Flatness Test (con't)

Level Accuracy and Flatness Test (MHz)	Results (dBm)		
	Min	Actual	Max
+3.0 dBm:			
10	+2.0	_____	+4.0
110	+2.0	_____	+4.0
150	+2.0	_____	+4.0
310	+2.0	_____	+4.0
320	+2.0	_____	+4.0
410	+2.0	_____	+4.0
510	+2.0	_____	+4.0
610	+2.0	_____	+4.0
640	+2.0	_____	+4.0
910	+2.0	_____	+4.0
1210	+2.0	_____	+4.0
1280	+2.0	_____	+4.0
2010	+2.0	_____	+4.0
2510	+2.0	_____	+4.0
Level Accuracy and Flatness Test (MHz)	Results (dBm)		
	Min	Actual	Max
-3.0 dBm:			
10	-4.0	_____	-2.0
110	-4.0	_____	-2.0
150	-4.0	_____	-2.0
310	-4.0	_____	-2.0
320	-4.0	_____	-2.0
410	-4.0	_____	-2.0
510	-4.0	_____	-2.0
610	-4.0	_____	-2.0
640	-4.0	_____	-2.0
910	-4.0	_____	-2.0
1210	-4.0	_____	-2.0
1280	-4.0	_____	-2.0
2010	-4.0	_____	-2.0
2510	-4.0	_____	-2.0
-12.0 dBm:			
10	-13.0	_____	-11.0
110	-13.0	_____	-11.0
150	-13.0	_____	-11.0
310	-13.0	_____	-11.0
320	-13.0	_____	-11.0
410	-13.0	_____	-11.0
510	-13.0	_____	-11.0
610	-13.0	_____	-11.0
640	-13.0	_____	-11.0
910	-13.0	_____	-11.0
1210	-13.0	_____	-11.0
1280	-13.0	_____	-11.0
2010	-13.0	_____	-11.0
2510	-13.0	_____	-11.0

Performance Test 7

Low Level Accuracy

1. The actual output level is calculated as follows:

- _____ power meter reading (step 3)
- + _____ exact value of attenuator
(at frequency MHz)
- + _____ difference observed (steps 4 and 5)
- = _____ actual output level where the indicated value
(level A) is _____ dBm.

Actual Output Level	Results		
	Min	Actual	Max
-60 to -119.9 dBm	A-1.0 dBm	_____	A+1.0 dBm
-120 dBm and below	A-3.0 dBm	_____	A+3.0 dBm

Performance Test 8

PHASE NOISE TEST

Offset Frequency f_{OFF}	SSB Phase Noise	
	Min.	Actual
10 Hz	-131 dBc	_____
100 Hz	-132 dBc	_____

Performance Test 9

SSB PHASE NOISE TEST (OPTIONAL)

Offset Frequency f_{OFF}	SSB Phase Noise	
	Min.	Actual
0 Hz	-100 dBc	_____
100 Hz	-112 dBc	_____
1 kHz	-121 dBc	_____
10 kHz	-131 dBc	_____
100 kHz	-132 dBc	_____

Performance Test 10

HARMONICS TEST

Frequency (MHz)	2nd Harmonic (MHz)	Results	
		Min	Actual
90.0	180.0	-30 dBc	_____
159.0	318.0	-30 dBc	_____
319.0	638.0	-30 dBc	_____
320.0	640.0	-30 dBc	_____
370.0	740.0	-30 dBc	_____
450.0	900.0	-30 dBc	_____
640.0	1280.0	-30 dBc	_____
745.0	1490.0	-30 dBc	_____

SPURIOUS TEST

Frequency (MHz)	Results	
	Min	Actual
320.000 000	-90 dBc	_____
320.000 010	-90 dBc	_____
320.000 030	-90 dBc	_____
320.000 100	-90 dBc	_____
320.000 300	-90 dBc	_____
320.001 000	-90 dBc	_____
320.003 000	-90 dBc	_____
320.010 000	-90 dBc	_____
320.030 000	-90 dBc	_____
320.100 000	-90 dBc	_____
329.999 990	-90 dBc	_____
329.999 970	-90 dBc	_____
329.999 900	-90 dBc	_____
329.999 700	-90 dBc	_____
329.999 000	-90 dBc	_____
329.997 000	-90 dBc	_____
329.970 000	-90 dBc	_____
329.900 000	-90 dBc	_____
103.980 000	-90 dBc	_____
640.000 000	-84 dBc	_____
1280.000 000	-78 dBc	_____

Performance Test 11

TIME BASE AGING RATE TEST

Calculated Rate Measured	Specification Rate Maximum
_____ $\times 10^{-10}$ /day	5×10^{-10} /day

Performance Test 12

640 MHz Output SSB Phase Noise

Offset	Measured Noise			Limit (dBc/Hz)
	Relative to Reference Level (dB/Hz)	Correction	Total (dBc/Hz)	
10 Hz	_____	-59 dB	_____	- 84
100 Hz	_____	-59 dB	_____	-104
1 kHz	_____	-59 dB	_____	-121
10 kHz	_____	-59 dB	_____	-145
100 kHz	_____	-59 dB	_____	-157
1 MHz	_____	-59 dB	_____	-157

640 MHz Output Level

Measured Level	Specification Level
_____ dBm	> + 1 dBm

Section 5 ADJUSTMENTS

5-1. INTRODUCTION

This section contains adjustments and checks that assure peak performance of the Signal Generator. The instrument should be readjusted after repair or failure to pass a performance test. Included in this section are test setups and illustrations that show locations of assemblies. Removal and disassembly procedures are given in Section 8.

The Signal Generator requires a 1 hour warmup period prior to making any adjustments. Before doing the 10 MHz Reference Oscillator Adjustment it is recommended the Signal Generator be connected to the main power (line) for at least 10 days. If a 10 day warmup period is impractical, the 10 MHz Reference Oscillator Adjustment can generally be performed after a 24 hour warmup.

The power supply voltages should be checked before making any other adjustments. Generally, the order in which the adjustments are performed is not critical. Exceptions to this are the Low Frequency Loop and Output Sections where adjustments tend to interact slightly with one another; therefore, it is recommended to do these adjustments in specific order. If all the adjustments are to be performed, it is recommended that the order of adjustments be performed as given in this section. The order of these adjustments follows the major signal flow of the Signal Generator (that is, power supply, reference section, phase lock loops, output section, and the digital control unit).

Determining the adjustments to be performed after a component failure and subsequent repair or a performance test failure is important. This will help keep the adjustment time to a minimum. Refer to the Related Adjustments column of Table 5-2. After the repair and/or adjustment, performance tests are usually required to verify performance.

5-2. SAFETY CONSIDERATIONS

This Section contains warnings and cautions which must be followed for your protection and to avoid damage to the equipment.

WARNING

Maintenance described in this section is performed with power supplied to the instrument and with protective covers removed. Maintenance should be performed only by service trained personnel who are aware of the hazard involved (for example, fire and electrical shock). Where maintenance can be performed without power applied, the power should be removed.

A pin-to-pin voltage difference of 60 Vdc may be found on many of the instrument's circuit board connectors. Be careful while working on the circuit boards with power supplied to the instrument. If a circuit board is placed on an extender board, the possibility of coming in contact with 60 Vdc is greatly increased. Be careful while working on the circuit boards with power supplied. Work with one hand. Do not touch the extender board.

The adjustment procedures do not require access to the interior of the power supply. If it becomes necessary to work on the power supply for any reason, refer to the power supply schematics for important warnings about high voltage.

WARNING

When working near the back of the Generator, take care not to let long hair be drawn into the fan. This could result in personal injury.

Capacitors inside the instrument may still be charged even if the instrument has been disconnected from its source of supply.

Before the instrument is switched on, all protective earth terminals, extension cords, auto-transformers and devices connected to it should be connected to a protective earth grounded socket. Any interruption of the protective earth grounding will cause a potential shock hazard that could result in personal injury.

Whenever it is likely that the protection has been impaired, the instrument must be made inoperative and be secured against any unintended operation.

Only 250V normal blow fuses with the required rated current should be used. Do not use repaired fuses or short circuited fuseholders. To do so could cause a shock or fire hazard.

CAUTION

Do not unplug the A4A1 AGC board or the A11A5 Modulation Board unless the instrument is unplugged or switched to standby. The A11A5 and A4A1 boards contain CMOS devices which may be damaged if the board is removed when the power is on.

5-3. EQUIPMENT REQUIRED

Each adjustment procedure contains a list of required test equipment. The test equipment is identified by callouts in the test setup diagrams included with each procedure.

If substitutions must be made for the recommended test equipment, refer to the Recommended Test Equipment table in Section 1 for the minimum specifications. It is important that the test equipment meet the critical specifications listed in the table if the Generator is to meet its performance requirements.

A service accessory kit, Hewlett-Packard accessory number 11714A, is required for servicing and troubleshooting the Signal Generator.

5-4. FACTORY SELECTED COMPONENTS

Factory selected components are identified on the schematics and parts list by an asterisk which follows the reference designator. The normal value or range of the components are shown. The manual change sheets will provide updated information pertaining to the selected components. Table 5-1 lists the reference designator, the process used in selecting a particular value, the normal value range, and the service sheet where the component part is shown.

5-5. POST-REPAIR ADJUSTMENTS

Table 5-2 lists the adjustments related to repairs or replacement of any of the assemblies.

Table 5-1. Factory Selected Components (1 of 3)

Reference Designator	Service Sheet	Range of Values	Process of Selection
A3A3R88 A3A7R1 A3A9R14	19 23 24	4.7 k Ω to 10 k Ω 1 k Ω to 5.11 k Ω 82.5 Ω to 162 Ω	These resistors should only need selection if: <ol style="list-style-type: none"> 1. The tank circuit inductor or varactor diodes were changed in the related VCO and: 2. The Generator subsequently failed the SSB Phase Noise or Harmonics and Spurious performance tests (bandwidth might be too wide), or switching speed too slow (bandwidth might be too narrow). For A3A3R88 and A3A7R1, increasing resistance decreases bandwidth. For A2A9R14 increasing resistance increases bandwidth.
A3A4R4	20	5.62 Ω to 14.7 k Ω	Selected to center the adjustment range of A3A4R4 (see N-Loop Phase error adjustment).
A3A7R27	23	1.47 k Ω to 100 k Ω	R27 affects loop bandwidth. With the Signal Generator set to 9.9 MHz, the sum loop VCO bandwidth should be 100 kHz minimum to 200 kHz maximum (with less than 3 dB peaking). If the loop bandwidth of the sum loop is too wide, R27 must be increased; if the bandwidth is too narrow, R27 must be decreased.
A3A10R1	25	26.1 Ω to 100 Ω	Set the Generator to 321 MHz, FM, 10 kHz peak deviation and EXT DC. Apply negative dc voltage (< -1V) to front-panel MODULATION INPUT so that the signal at A3A8TP1 is approximately 110 MHz. Select R1 at approximately 150 kHz below the carrier level of spurious signal < -70 dBc. If this level cannot be obtained, check A11A2R51. Then reselect R1.
A4A2A1R6 A4A2A1R7 A4A2A1R8	33	See Table 5-3	These resistors form a pad with attenuation that varies from 0 to 8 dB. To determine if the value of the pad must be changed, proceed as follows: <ol style="list-style-type: none"> 1. Set the Signal Generator to 2.0 GHz, +16.0 dBm, and Special Function 85. Connect a DVM to A4A1TP14 and adjust DOUBLER #2 DRIVE (A4A1R34) for a DVM reading of +10.1 Vdc. 2. Connect the DVM to A4A1TP1. Set the Signal Generator to +5.1 dBm with Special Function 85 active. Use manual sweep to cover the frequency range from 1280 to 2560 MHz. Note high and low DVM readings. If DVM readings are in the range, +3.2 to +8.0 Vdc, the pad value should not be changed. If the DVM reading is not in this range, continue with step 3. 3. If a DVM reading is below +3.2 Vdc, the pad attenuation must be increased. Likewise, if a DVM reading is above +8.0 Vdc, the pad attenuation must be decreased. Measure the value of the resistors presently installed and change to the next higher or lower pad value. A 1 dB change will produce a large change in voltage at A4A1TP1. Table 5-3 shows resistor values for the pads and Table 5-2 lists the HP Part Number of the chip resistors used in these pads. 4. Repeat steps 1 and 2 to see if DVM readings are now within required range.

Table 5-1. Factory Selected Components (2 of 3)

Reference Designator	Service Sheet	Range of Values	Process of Selection
A6A1R46	2	75Ω to 178Ω	Connect a 10 MHz (+7.5 dBm) signal to the EXTERNAL REFERENCE INPUT of the Signal Generator. Select R46 for +6 dBm at the A6A1J2 output (160 MHz).
A11A2R4	43	4.22 kΩ to 5.62 kΩ	Set the Generator to 100 MHz with Special Function 51 selected. Inject a 1 kHz sine wave at 2.83 Vrms into the AUX FM INPUT. Select A11A2R4 for actual peak deviation of 100 +5 kHz at the Generator's RF OUTPUT.
A11A2R7	43	3.16 kΩ to 5.11 kΩ	A11A2R7 is chosen so that A11A2R9 is in the center of its range when the FM deviation called for on the front panel is present at the RF output.
A11A2R21-R24 A11A2R29 A11A2R32	43	No Limit 2.61 kΩ, 3.16 kΩ, 3.83 kΩ, 1.47 kΩ, 2.15 kΩ, 2.87 kΩ,	Adjustments need only be made when the varactors are replaced. The adjustment procedure is complicated and requires a dedicated test setup. It is recommended that this board be replaced with a new board from the factory in the event that repair or adjustment becomes necessary.
A11A2R51	43	26.5Ω to 56.2Ω	Set the Generator to FM, 30 kHz peak deviation and EXT DC. Apply negative dc voltage (< -1V) to the front panel MODULATION INPUT so that the signal at A4A10J5 is approximately 20.025 MHz. Select R51 for a level between -13 and -18 dBm. Check for a spurious signal at approximately 19.875 MHz. Its level should be < -73 dBc. If not, increase the level of the 20.025 MHz signal (-13 dBm maximum).
A12A2R9	31	No Limit	This procedure adjusts the gain of the Q3 amplifier on A12A2. It should only be performed if the microcircuit on the A12A1 assembly is changed and pulse modulation rise and fall time in the 120.0 to 640.0 MHz frequency range does not meet specifications, or maximum output level is less than +18.0 dBm in this frequency range. This procedure requires many iterations and can be very time consuming. The basic procedure is to change A12A2R9 and A12A2R13 in pairs until the desired performance is obtained. R9 is either increased or decreased from the value in the circuit based on the following criteria: <ol style="list-style-type: none"> 1. Increasing R9 increases the gain of the amplifier which increases the output level but decreases pulse modulation rise and fall time. 2. Decreasing R9 decreases the gain of the amplifier which decreases output level but increases rise and fall time. <p>Determine the value of R9 presently in the circuit and increase or decrease the value to obtain the desired result.</p>
A12A2R13		No Limit	The new value of A12A2R13 is calculated based on the new value selected for A12A2R9 using the following formula: $R13 = \frac{2500}{R9}$ <p>Use standard 1% resistors for R9. R13 consists of chip resistors which may have to be paralleled to obtain the calculated value. Chip resistors which can be used are listed in Table 5-3.</p>

Table 5-1. Factory Selected Components (3 of 3)

Reference Designator	Service Sheet	Range of Values	Process of Selection										
A12A2L11	31	No Limit	This inductor determines the roll-off of amplifier Q3 on A12A2 in the 120 to 640 MHz band of output frequencies. It should only be necessary to change this part if the output amplifier micro-circuit on the A12A1 assembly is changed and front panel output level of +18.0 dBm cannot be obtained in the upper part of the 120 to 640 MHz frequency range. If the bandwidth of the amplifier is too large, spurious oscillations could be generated. Decreasing the value of the inductor increases the bandwidth of the amplifier. Determine the value of the inductor presently installed in the circuit. Change the inductor value in small steps until the desired performance is obtained.										
A12A2R29-R32	31	See table 5-3	The resistors form a pad with attenuation that varies from 0 to 8 dB. This pad should only be changed if AM distortion is too high and maximum output level is more than +19 dBm in the frequency range from 120 to 640 MHz. Increase the attenuation of the pad until AM distortion in normal or maximum output level is below +19 dBm in this frequency band. Table 5-3 lists resistance values for the pads and lists the HP part numbers for the chip resistors used in these pads.										
A12A3R19 A12A3R21 A12A3R23	30	See Table 5-3	Verify that the signal level at A12A3J1 is -16 dBm. Choose values for the attenuator pad formed by R19, R21, and R23 so that the signal level at A12A1J2 is as close as possible, but not less than +10 dBm. Values for the pads are given in table 5-3.										
A12A5R1 A12A5R3 A12A5R7	29	See Table 5-3	Selected for minimum spurs at A12A1J4. Connect a 1 dB step attenuator between A4A3J3 and A12A5J1. Connect a spectrum analyzer to A12A1J4. Set the Signal Generator to 40 MHz (+10 dBm) and the spectrum analyzer for a center frequency of 40 MHz (with a 1 MHz span) and a reference level of +10 dBm. Now, set the Signal Generator to 120 MHz and set the step attenuator for a minimum amplitude level at 40 MHz. Repeat this procedure for the following frequencies: <table style="margin-left: auto; margin-right: auto;"> <thead> <tr> <th>Frequency of Carrier</th> <th>Frequency of Spur</th> </tr> </thead> <tbody> <tr> <td>120 MHz</td> <td>40 MHz</td> </tr> <tr> <td>110 MHz</td> <td>80 MHz</td> </tr> <tr> <td>100 MHz</td> <td>120 MHz</td> </tr> <tr> <td>90 MHz</td> <td>160 MHz</td> </tr> </tbody> </table> Record the amount of attenuation of the 1 dB step attenuator and insert the appropriate pad (formed by R1, R3, and R7) given in Table 5-3.	Frequency of Carrier	Frequency of Spur	120 MHz	40 MHz	110 MHz	80 MHz	100 MHz	120 MHz	90 MHz	160 MHz
Frequency of Carrier	Frequency of Spur												
120 MHz	40 MHz												
110 MHz	80 MHz												
100 MHz	120 MHz												
90 MHz	160 MHz												

Table 5-2. Post-Repair Adjustment Procedures (1 of 2)

Assembly Replaced or Repaired	Related Adjustments
AT1 and AT2	RF Level Adjustments (25)
A1A1 to A1A3	None
A2A1	None
A2A2	Z-Axis Marker Level Adjustment (34)
A2A3 to A2A10	None
A3A1	None
A3A2	N Loop ECL Adjustment (9)
A3A4	N Loop Fractional-N Spur Adjustment (11)
A3A5	N Loop Phase Error Adjustment (10)
A3A6	N Loop Fractional-N Spur Adjustment (11)
A3A7	N Loop Fractional-N Spur Adjustment (11)
A3A8	None
A3A9, A3A10	Sum Loop Phase Error Adjustment (12)
A4A1	FM Sum Loop Pretune Adjustment (13)
A4A2	None
A4A3	RF Level Adjustments (25)
A4A4	Pulse Modulation Drift Adjustments (27)
	ALC Loop Bandwidth Adjustments (26)
	Doubler #2 Filter Tracking Adjustments (31)
	Doubler #2 Amplifier Bias Adjustments (32)
	Low Pass Filter Adjustments (33)
	Phase Modulation Adjustments (21)
	BPSK Adjustments (23)
	Phase Modulation Spur Adjustment (22)
A5A1, A5A2	None
A5A3	Fractional-N Correction Current Adjustment (8)
A5A4	None
A5A5	Fractional-N Pretune Adjustments (7)
A6A1	40 MHz Crystal Filter Adjustment (3)
A6A2	140 MHz Bandpass Filter Adjustment (6)
A6A3	160 MHz and 640 MHz Bandpass Filter Adj. (4)
A6A4	480 MHz Bandpass Filter Adjustment (5)
A6A5	Output Sum Loop Pretune Adjustment (17)
	Output Sum Loop Out-of-Lock Adjustment (18)
	Reference Sum Loop Pretune Adjustment (15)
	Reference Sum Loop Out-of-Lock Adjustment (16)
A6A6 to A6A8	None
A6A9	Controller Board Power Supply (-30V) Adj. (14)
A7A1, A7A2	Power Supply Voltage Adjustment (1)
A7A3, A7A4	None
A8A1, A8A2	None
A8A3	10 MHz Reference Oscillator Adjustment (2)
	40 MHz Crystal Filter Adjustment (3)
	160 MHz and 640 MHz Bandpass Filter Adj. (4)
	480 MHz Bandpass Filter Adjustment (5)
	140 MHz Bandpass Filter Adjustment (6)

Table 5-2. Post-Repair Adjustment Procedures (2 of 2)

Assembly Replaced or Repaired	Related Adjustments
A11A1	Variable Modulation Oscillator Adjustments (19)
A11A2	AM-FM Adjustments (20)
A11A3	AM-FM Adjustments (20)
A11A4	Phase Modulation Adjustments (21)
A11A5	BPSK Adjustments (23)
A12A1	None
A12A2	AM-FM Adjustments (20)
A12A1	Output Amplifier Bias Adjustments (24)
	RF Level Adjustments (25)
	Pulse Modulation Drift Adjustments (27)
	ALC Loop Bandwidth Adjustments (26)
A12A2	Low Pass Filter Adjustments (33)
A12A3	None
A12A4	Doubler #1 Tracking Filter Adjustment (29)
	Doubler #1 Balance Adjustment (30)
A12A5	Low Frequency Down Converter Adjustment (28)

Table 5-3. Standard Attenuation Pad Values and Chip Resistors Used In Pads

Standard Pad Attenuation Values		
Attenuation (dB)	Shunt R (ohms)	Series* R (ohms)
0	0	11.6
1	870	11.6
2	436	11.6
3	287	17.6
4	220	23.8
5	178	30.4
6	150	37.3
7	130	44.8
8	116	52.8

* Two Resistors of this value in parallel are used.

Chip Resistors Used in Pads			
Resistance (ohms)	HP Part Number	Resistance (ohms)	HP Part Number
0	0699-1503	121	0699-1417
10	0699-1344	147	0699-1419
12.1	0699-1346	178	0699-1421
17.8	0699-1350	196	0699-1422
21.5	0699-1352	261	0699-1425
26.1	0699-1354	316	0699-1427
31.6	0699-1356	422	0699-1430
38.3	0699-1358	511	0699-1432
46.4	0699-1360	825	0699-1437
51.1	0699-1361		

ADJUSTMENT 1

POWER SUPPLY VOLTAGE ADJUSTMENT

• Service Sheets 65 and 66.

Description

The +5.2Vdc, +20Vdc, -10Vdc and -40Vdc power supply output voltages are adjusted.

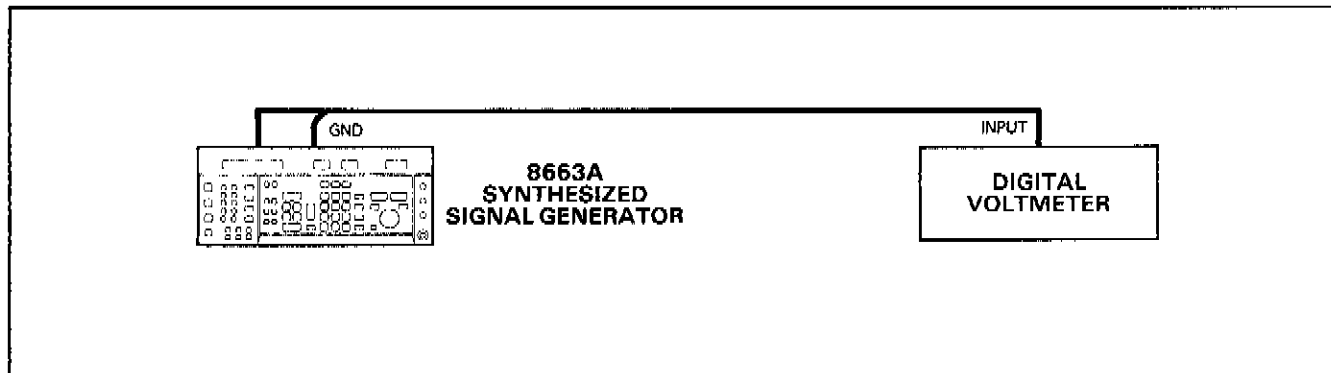

Figure 5-1. Power Supply Voltage Adjustment Setup

Equipment

Digital Voltmeter (DVM) HP 3466A

NOTE

Refer to Assembly Locations, on foldout at the end of Section 5, for the location of all assemblies referenced in this procedure.

Procedure

WARNING

These test procedures do not require access to the interior of the power supply. If it becomes necessary to work on the power supply for any reason, care must be taken due to internally exposed high voltages. Refer to the warnings on the schematics of the power supply section for further information.

1. Connect the test leads of the DVM to ground and the +5.2V test point (through the top cover of the power supply section) of the Signal Generator.
2. Set the +5.2V adjustment to $+5.20 \pm 0.01V$. AC ripple should be no more than 10 mV.
3. Connect the DVM to the +20V test point.
4. Set the +20V adjustment so that the DVM reads $+20.00 \pm 0.05V$. AC ripple should be no more than 10 mV.

5. Connect the DVM to the -10V test point.
6. Set the -10V adjustment pot so that the DVM reads $-10.00 \pm 0.02\text{V}$. AC ripple should be no more than 10 mV .
7. Connect the DVM to the -40V test point.
8. Set the -40V adjustment pot so that the DVM reads $-40.00 \pm 0.10\text{V}$. AC ripple should be no more than 10 mV .

ADJUSTMENT 2

10 MHz REFERENCE OSCILLATOR ADJUSTMENT

• Service Sheet 1.

Description

The 10 MHz OUTPUT from the Signal Generator (rear panel) is compared against a frequency standard with a long term stability greater than 1×10^{-10} . The frequency of the reference oscillator is fine tuned for minimum drift using the 10 MHz Reference Oscillator Adjustment.

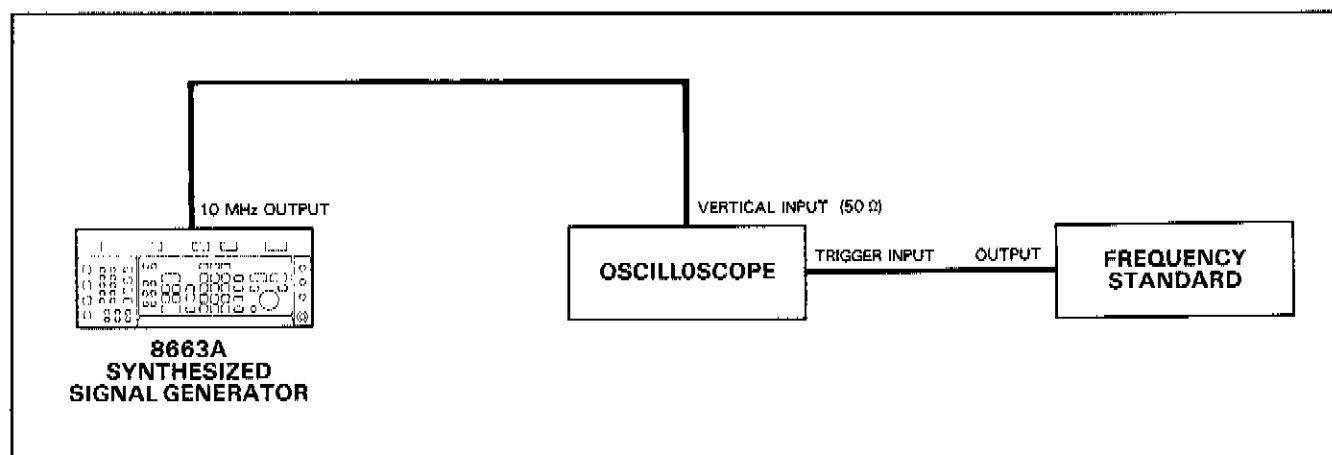

Figure 5-2. 10 MHz Reference Oscillator Adjustment Setup

Equipment

Frequency Standard HP 5065A
Oscilloscope HP 1741A

NOTE

Refer to Assembly Locations, on foldout at the end of Section 5, for the location of all assemblies referenced in this procedure.

Procedure

WARNING

Be careful working near the fan at the back of the Generator. Long hair can be drawn into the fan causing personal injury.

1. Connect an RF cable from the frequency standard to the vertical input of the oscilloscope.
2. Adjust the oscilloscope so that at least one cycle of the sine waveform can be viewed on the oscilloscope screen.
3. Now, connect the equipment as shown in Figure 5-2.
4. Set the oscilloscope for external triggering input and adjust for synchronized (stable) display.
5. Depress the rear panel frequency reference INT 10 MHz switch.
6. Set the FREQ. ADJ. (back side of the Signal Generator; crystal oscillator assembly) so that the waveform on the oscilloscope does not drift more than one cycle in ten seconds.

ADJUSTMENT 3

40 MHz CRYSTAL FILTER ADJUSTMENT

• Service Sheet 2.

Description

The 80 MHz OUTPUT signal at A6A1J1 is measured with a spectrum analyzer while A6A1C27, C31, C34, and C38 are adjusted for maximum 80 MHz output level.

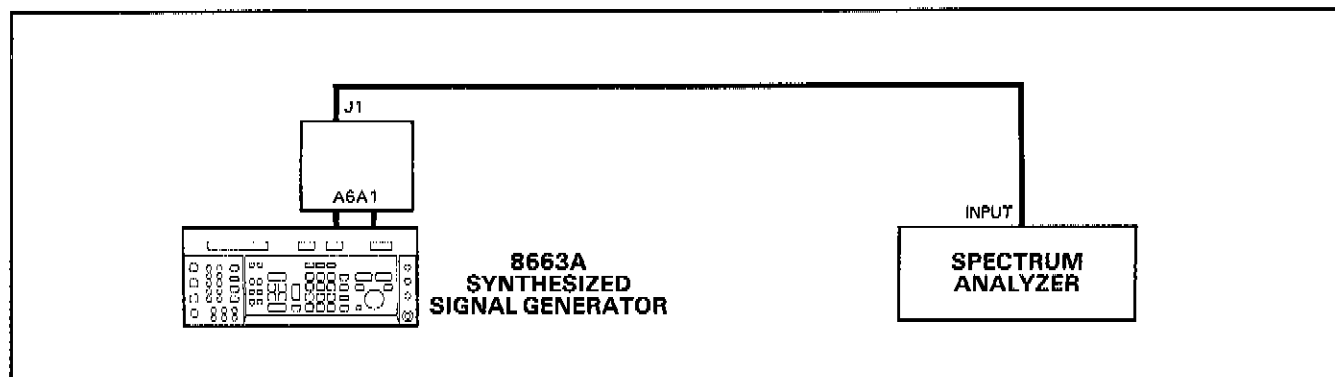

Figure 5-3. 40 MHz Crystal Filter Adjustment Setup

Equipment

Spectrum Analyzer, RF	HP 8558B/141T
Extender Board, 30 pin	08662-60276

NOTE

Refer to Assembly Locations, on foldout at the end of Section 5, for the location of all assemblies referenced in this procedure.

Procedure

1. Place the A6A1 LF Multiplier Board on an extender board.
2. Set the Signal Generator's control for Special Function 00 (press the Blue Key, Special and 00).
3. Set spectrum analyzer center frequency to 80 MHz, and reference level to +10 dBm.
4. Connect the 80 MHz OUTPUT, A6A1J1, to the spectrum analyzer.
5. Adjust variable capacitors A6A1C27, C31, C34, and C38 to obtain the maximum signal level on the spectrum analyzer. The signal level should be +3 to +6 dBm.

NOTE

These adjustments are interactive and several iterations may be required.

6. Check to see that the 10 MHz side bands (that is, 70 and 90 MHz) are >60 dB below the carrier.

ADJUSTMENT 4

160 MHz AND 640 MHz BAND-PASS FILTER ADJUSTMENT

- Service Sheet 2 and 3.

Description

The 640 MHz signal at A6A3TP2 is measured with a spectrum analyzer while A6A3C13, C15, C16, C17, and C81 are adjusted for maximum 640 MHz output level.

NOTE

Variable capacitors A6A3C13, C15, C16, and C17 adjust the response of the 160 MHz Band-Pass Filter; A6A3C81 adjusts the response of 640 MHz Band-Pass Filter.

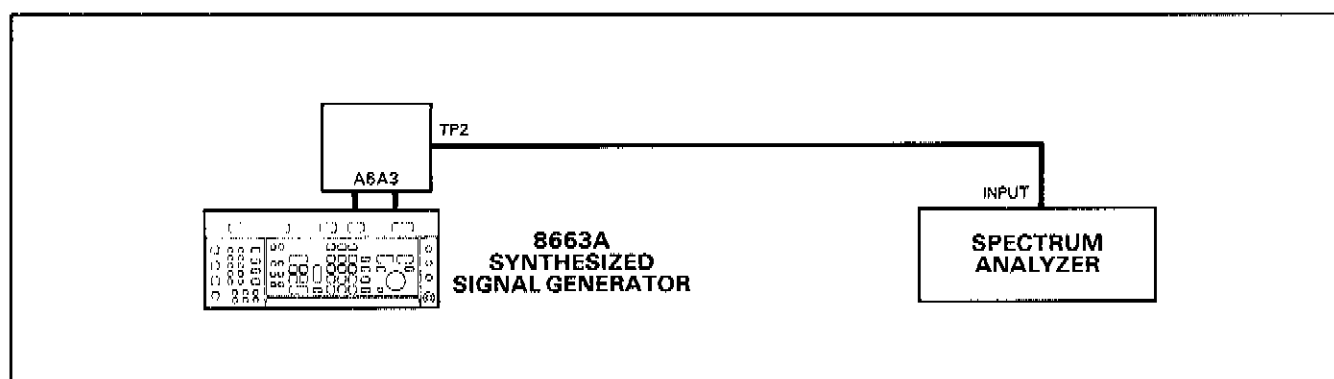

Figure 5-4. 160 MHz and 640 MHz Band-Pass Filter Adjustment Setup

Equipment

Spectrum Analyzer, RF	HP 8558B/141T
RF Test Probe, Ac coupled	HP 1250-1598
Extender Board	HP 08662-60276

NOTE

Refer to Assembly Locations, on foldout at the end of Section 5, for the location of all assemblies referenced in this procedure.

Procedure

1. Place the A6A3 HF Multiplier on an extender board. Connect an RF cable from the 160 MHz OUTPUT (A6A1J2) to the 160 MHz INPUT (A6A3J2).
2. Set the Signal Generator's control for Special Function 00 (press the Blue Key, Special and 00).
3. Set spectrum analyzer center frequency to 640 MHz and reference level to +10 dBm.
4. Connect the spectrum analyzer input to A6A3TP2 (RF Test Point) using the special capacitor coupled cable adaptor found in the service kit.
5. Adjust variable capacitors A6A3C13, C15, C16, and C17 to obtain the maximum signal level on the spectrum analyzer.

NOTE

Variable capacitors A6A3C13, C15, C16, and C17 are interactive and several iterations may be required.

6. Adjust variable capacitor, A6A3C81, for maximum output signal level. The signal level should be +1 to +10 dBm (typically +5 dBm).

ADJUSTMENT 5

480 MHz BAND-PASS FILTER ADJUSTMENT

- Service Sheet 2 and 3.

Description

The 480 MHz signal at A6A3TP10 is measured with a spectrum analyzer while A6A3C46 is adjusted for maximum level at the output of the 480 MHz Band-Pass Filter.

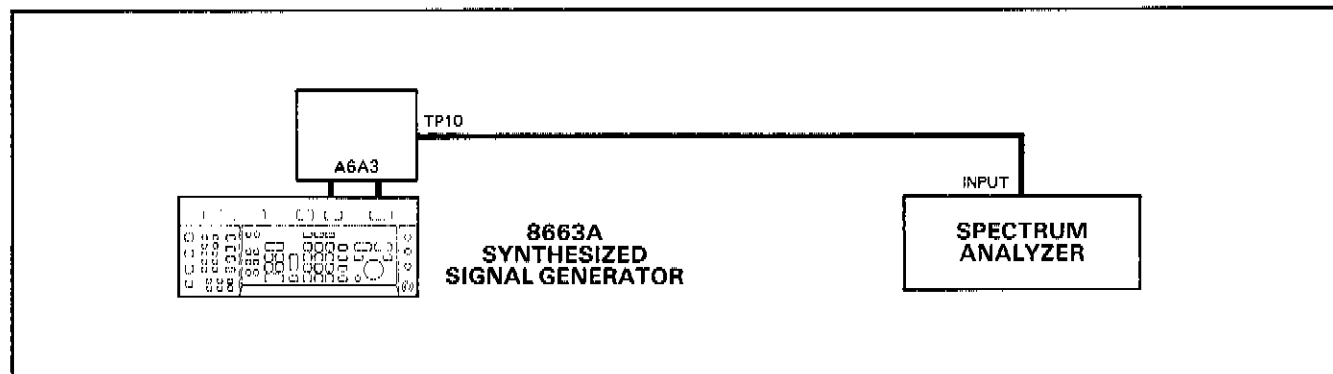

Figure 5-5. 480 MHz Band-Pass Filter Adjustment Setup

Equipment

Spectrum Analyzer, RF	HP 8558B/141T
RF Test Probe, ac coupled	HP 1250-1598
Extender Board, 30 pin	HP 08662-60276

NOTE

Refer to Assembly Locations, on foldout at the end of Section 5, for the location of all assemblies referenced in this procedure.

Procedure

1. Place the A6A3 HF Multiplexer on an extender board. Connect an RF cable from the 160 MHz OUTPUT (A6A1J2) to the 160 MHz INPUT (A6A3J2).
2. Set the Signal Generator's control for Special Function 00 (press the Blue Key, Special, and 00).
3. Set spectrum analyzer center frequency to 480 MHz and reference level to +10 dBm.
4. Connect the spectrum analyzer input to A6A3TP10 (RF Test Point) using the special capacitor coupled cable adaptor found in the service kit.
5. Adjust variable capacitor A6A3C46 to obtain the maximum signal level as viewed on the spectrum analyzer. The signal level should be -6 to +3 dBm (typically 0 dBm).

ADJUSTMENT 6

140 MHz BAND-PASS FILTER ADJUSTMENT

- Service Sheet 2 and 4.

Description

The 140 MHz signal at A6A2J2 (60-140 MHz) is measured with a spectrum analyzer while A6A2C30 is adjusted for maximum level at the output of the 140 MHz Band-Pass Filter.

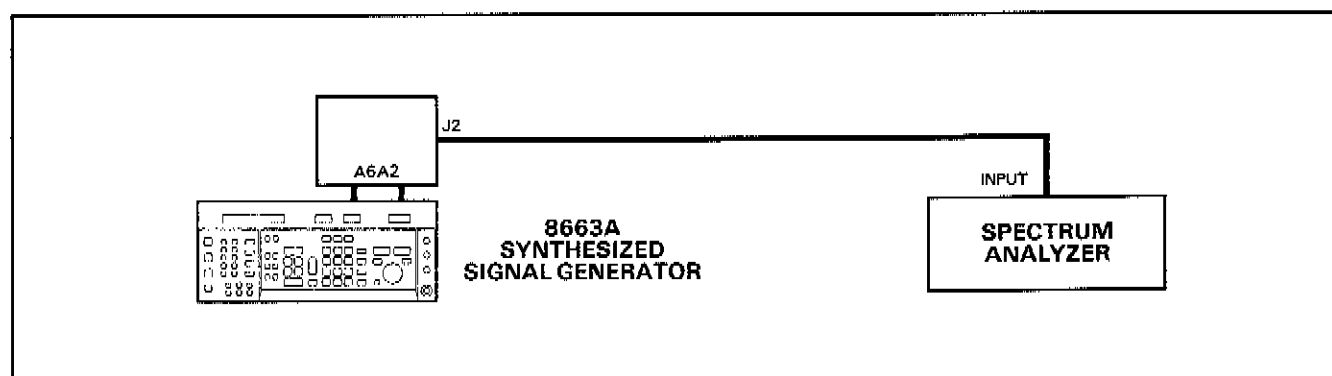

Figure 5-6. 140 MHz Band-Pass Filter Adjustment Setup

Equipment

Spectrum Analyzer, RF	HP 8558B/141T
Extender Board	HP 08662-60276

NOTE

Refer to Assembly Locations, on foldout at the end of Section 5, for the location of all assemblies referenced in this procedure.

Procedure

1. Place the A6A2 LO DRIVE on an extender board. Connect an RF cable from the 80 MHz OUTPUT (A6A1J1) to the 80 MHz INPUT (A6A2J1).
2. Set the Signal Generator's control for Special Function 00 (press the Blue Key, Special, and 00).
3. set spectrum analyzer center frequency to 140 MHz and reference level to +10 dBm.
4. Connect the spectrum analyzer input to the 60 MHz-140 MHz OUTPUT (A6A2J2).
5. Adjust variable capacitor A6A2C30 to obtain maximum signal level on the spectrum analyzer. The signal level should be +3 dBm to +10 dBm (typically +9 dBm).

ADJUSTMENT 7

FRACTIONAL-N PRETUNE ADJUSTMENT

• Service Sheet 15.

Description

An oscilloscope is set up to monitor the FN Loop error voltage while the Signal Generator is sweeping between two selected frequencies. The A5A5R53 OFFSET pot is adjusted to center the ac components of the FN Loop error voltage on a +3 Vdc offset level. Then the A5A5R24 GAIN pot is adjusted to minimize the ac components.

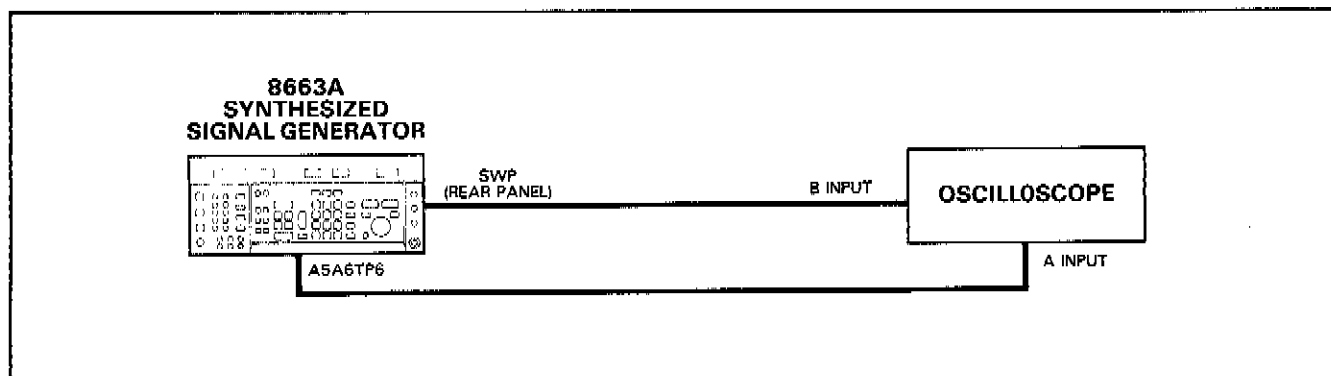

Figure 5-7. Fractional N Pretune Adjustment Setup

Equipment

Oscilloscope (with divide-by-10 probe) HP 1741A

NOTE

Refer to Assembly Locations, on foldout at the end of Section 5, for the location of all assemblies referenced in this procedure.

Procedure

1. Connect the scope probe to A5A6TP6 (Fractional-N Loop Motherboard). Set the oscilloscope to X-Y mode; set the vertical controls to 0.1 volt per division with dc coupling on CH A and CH B to 1V per division, dc coupling.
2. Set the Signal Generator's controls as follows:

START FREQ	320 MHz
STOP FREQ	320.1 MHz
STEP SIZE	6.1875 kHz
TIME/STEP	0.5 ms
MODE	AUTO

NOTE

The following adjustments may not result in an oscilloscope display exactly as shown in Figure 5-8. The intended result, however, is to reduce the peak-to-peak ac amplitude to the lowest possible amount and to center the signal around the indicated dc level.

3. Adjust the PRETUNE OFFSET, A5A5R53, so that the peak-to-peak FN Loop error voltage varies symmetrically around a +3 Vdc offset. Refer to Figure 5-8.
4. Adjust the PRETUNE GAIN, A5A5R24, to minimize the peak-to-peak FN Loop error voltage. It should read within 8 Vp-p centered on the +3 Vdc offset. Ignore the upper and lower overshoot (broken lines) when measuring the peak-to-peak swing.

NOTE

The Pretune Offset and Pretune Gain adjustments are interactive and several iterations may be required.

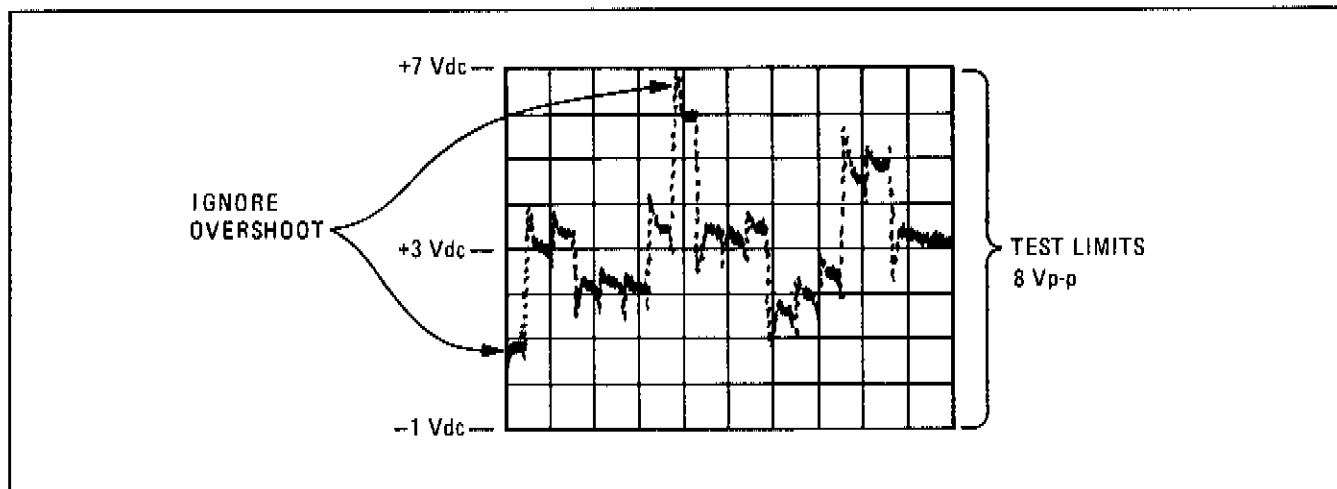

Figure 5-8. FN Loop Error Voltage (Vertical Sensitivity = 1V)

ADJUSTMENT 8

FRACTIONAL-N CORRECTION CURRENT ADJUSTMENT

- Service Sheet 14 and 15.

Description

The Fractional-N Correction Current is adjusted to minimize spurious outputs located at 10 kHz from the FN Loop VCO carrier frequency. Adjustments are made at VCO frequency settings of 100.090 MHz (for A5A3R40) and 100.099 MHz (for A5A3R39).

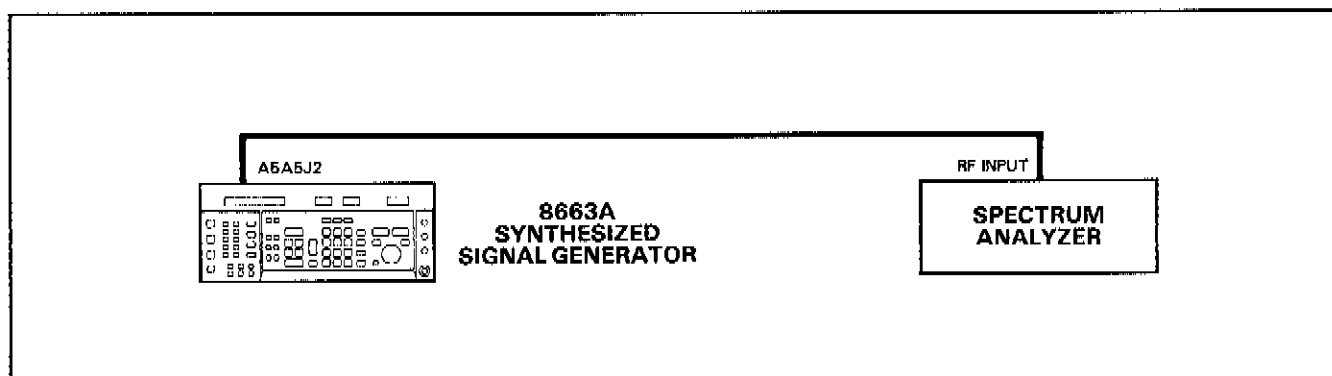

Figure 5-9. Fractional N Correction Current Adjustment Setup

Equipment

Spectrum Analyzer, RF HP 8558B/141T

NOTE

Refer to Assembly Locations, on foldout at the end of Section 5, for the location of all assemblies referenced in this procedure.

Procedure

1. Connect the spectrum analyzer's input to the 100 MHz to 200 MHz OUTPUT (A5A5J2).
2. Set the spectrum analyzer center frequency to 100.09 MHz, frequency span to 5 kHz per division, and resolution bandwidth of 1 kHz. Use reference level controls (set for 10 dB per division) to set signal peak to top graticule line on display.
3. Set the Signal Generator's controls for a frequency of 320.099910 MHz (which corresponds to a VCO frequency of 100.090 MHz).
4. Adjust CORRECTION CURRENT DF2, A5A3R40, to minimize the spurious output located 20 kHz away from the carrier. The spurious output should be at least 45 dB below the carrier.
5. Set the Signal Generator's controls for a frequency of 320.099901 MHz (which corresponds to a VCO frequency of 100.099 MHz).
6. Change the spectrum analyzer's center frequency to 100.099 MHz.
7. Adjust CORRECTION CURRENT DF1, A5A3R39, to minimize the spurious output located 10 kHz away from the carrier. The spurious output should be at least 45 dB below the carrier.

ADJUSTMENT 9

N-LOOP ECL ADJUSTMENT

- Service Sheet 18 and 20.

Description

The A3A3R13 BIAS adjustment tunes the sensitivity of the circuitry which guides the loop to lock.

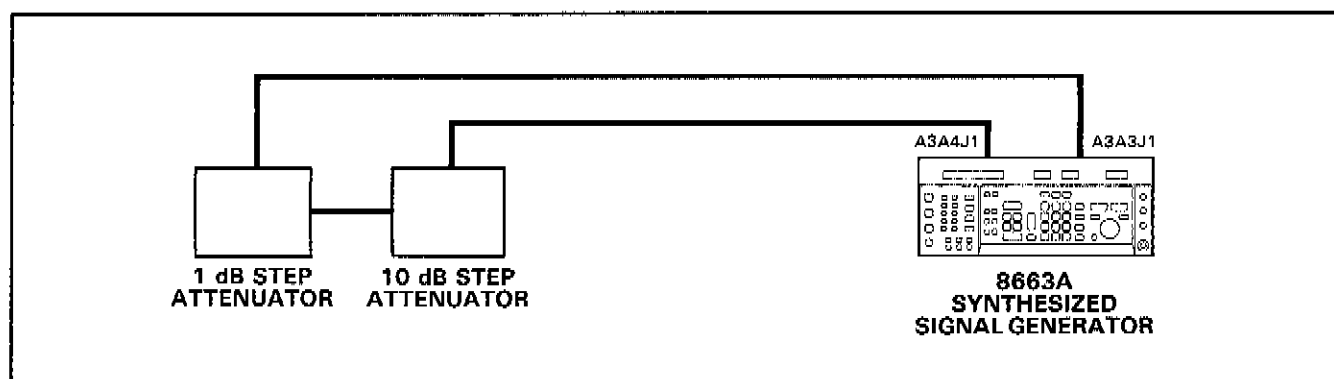

Figure 5-10. N-Loop ECL Adjustment Setup

Equipment

Attenuator, 1 dB steps	HP 355C
Attenuator, 10 dB steps	HP 355D

NOTE

Refer to Assembly Locations, on foldout at the end of Section 5, for the location of all assemblies referenced in this procedure.

Procedure

1. Connect the 1 dB and 10 dB step attenuators in series and install them between the A3A4J1 N-Loop VCO Output, and the A3A3J1 N-Loop Divider Input.
2. Set the Signal Generator as follows:

START FREQ	10.00 MHz
STOP FREQ	19.89 MHz
SET SIZE	0.1 MHz
SWEEP TIME/DIVISION	0.5 ms
SWEEP MODE	AUTO
3. Increase attenuation (using the two attenuators) from 0 dB to a point at which the loop just begins to break lock. This can be determined by viewing ERROR LED #03, on top of the A3A3 board.
4. Adjust the ECL BIAS adjustment, A3A3R13, so that ERROR LED #03 glows as dimly as possible.
5. Alternately increase attenuation and adjust the ECL BIAS pot until no further improvement in sensitivity can be made.
6. Recheck lower attenuations to insure that the loop remains locked.
7. The loop should lock with a minimum of 6 dB attenuation. Typical is 10–15 dB attenuation.

Adjustment 10

N-LOOP PHASE ERROR ADJUSTMENT

- Service Sheet 19 and 20.

Description

The closed-loop phase error signal is adjusted with the POSITION and GAIN controls.

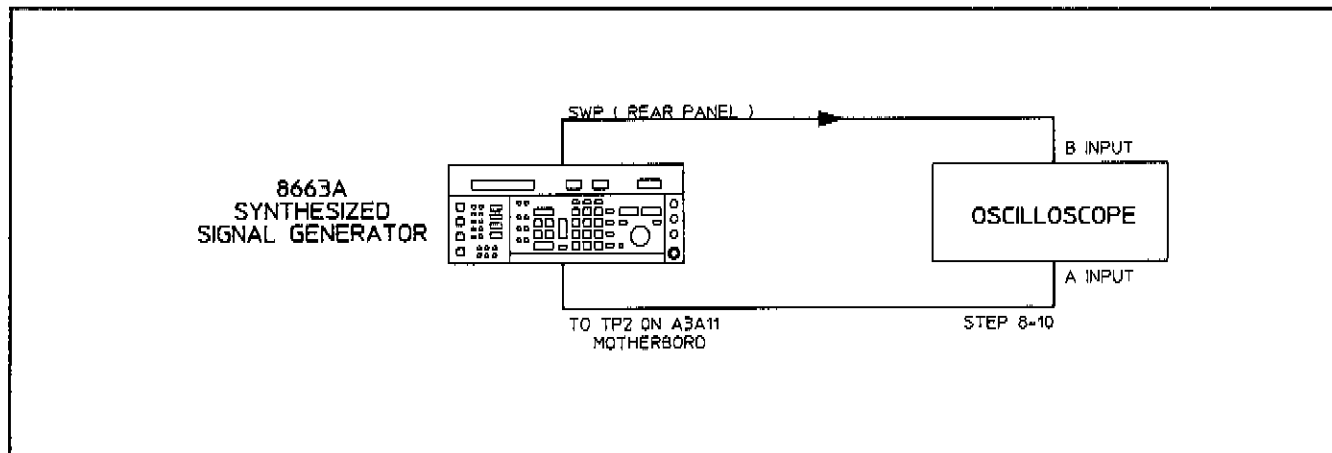

Figure 5-11. N-Loop Phase Error Adjustment Setup

Equipment

Option 031 Oscilloscope HP 1741A

NOTE

Refer to Assembly Locations, on foldout at the end of Section 5, for the location of all assemblies referenced in this procedure.

Procedure

1. Set the Signal Generator's controls as follows:

START FREQ	320.00 MHz
STOP FREQ	329.90 MHz
SET SIZE	0.1 MHz
TIME/STEP	0.5 ms
SWEEP MODE	AUTO
2. Set the oscilloscope to X-Y mode.

3. Connect the Generator's SWEEP OUTPUT to the oscilloscope's Y input. If the A3A4 board is on an extender, connect A3A4TP8 to the oscilloscope's X input. Test point A3A11TP2 on the bottom of the Generator can be used, instead of A3A4TP8, if more convenient (see Figure 5-12).
4. Adjust POSITION (A3A4R1) and GAIN (A3A4R3) until the displayed phase error signal is $0 \pm 0.2V$ throughout the entire sweep (see Figure 5-12). If POSITION does not have enough range, change the value of A3A4R4 adjustment within the limits described in Table 5-1.

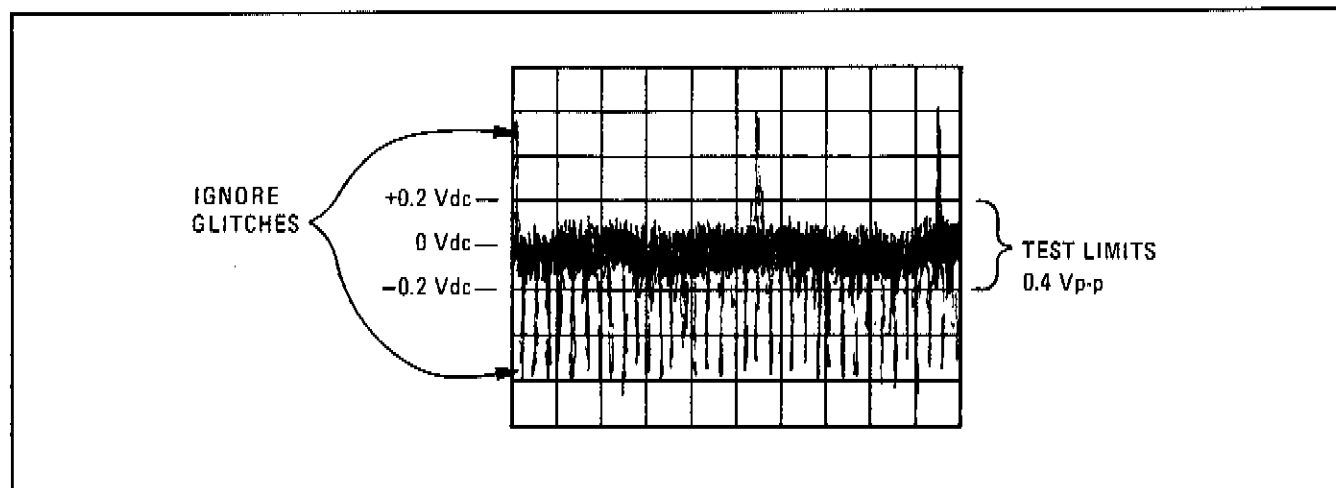

Figure 5-12. N-Loop Phase Error Signal Waveform (Adjusted correctly at $0 \pm 0.2V$)

5. After completing this adjustment, confirm that the Low Frequency Section is functioning correctly by viewing ERROR LIGHTS #05, #04, and #03 (on the top covers of assemblies A3A10, A3A6, and A3A3, respectively). With the Signal Generator sweeping 10 kHz and 1.2 GHz (1000 steps, 0.5 ms/steps), these lights should either be glowing or flashing very dimly. When the SWEEP mode is disabled, these lights should not glow or flash.

ADJUSTMENT 11

N LOOP FRACTIONAL-N SPUR ADJUSTMENT

- Service Sheet 18, 19 and 20.

Description

Spurs at 1, 2, 3, and 4 MHz above the carrier (out of the A3A4 assembly) are adjusted for minimum amplitude.

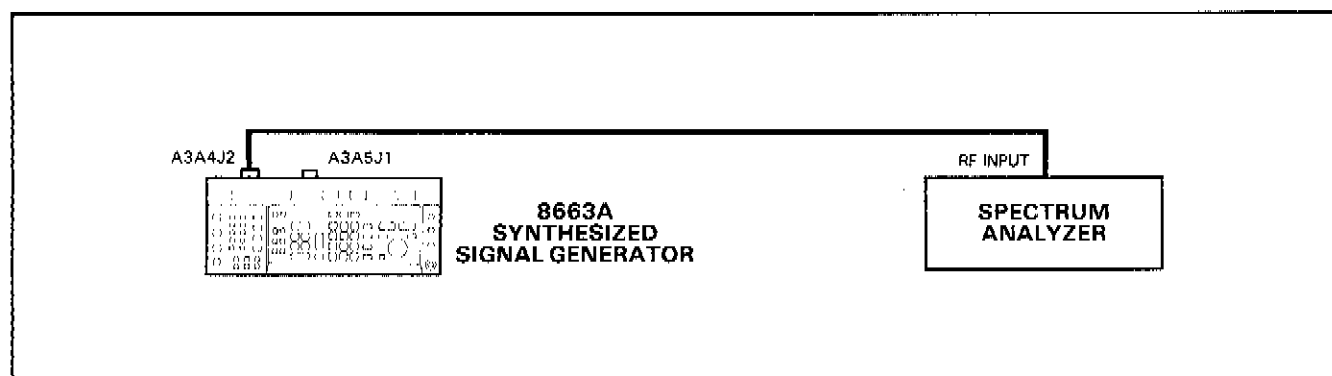

Figure 5-13. N Loop Fractional-N Spur Adjustment Setup

Equipment

Spectrum Analyzer, RF HP 8558B/141T

NOTE

Refer to Assembly Locations, on foldout at the end of Section 5, for the location of all assemblies referenced in this procedure.

Procedure

1. Disconnect the N Loop VCO Output, A3A4J2, from the Sum Loop Mixer Input, A3A5J
2. Connect an RF cable from A3A4J2 to the input of the spectrum analyzer.
3. Set the Signal Generator as follows:

FREQUENCY	12.9 MHz
AMPLITUDE	AMPTD OFF
MODULATION	MOD OFF
4. Set the spectrum analyzer as follows:

Center Frequency	151 MHz
Frequency Span/Division	1 MHz
Resolution Bandwidth	30 kHz
Video Filter	Minimum noise floor
5. Adjust the 1 MHz notch filter, through the top cover of A3A3, until the spur at 152 MHz becomes visible (that is, 1 MHz above the 151 MHz output of VCO).
6. Adjust the video filter (or Bandwidth adjustment) on the spectrum analyzer to obtain an absolute minimum noise floor.

7. Adjust the 1 MHz notch filter, this time for a minimum spur level. The spur level should be at least 75 dB below the center frequency (151 MHz) level.
8. Repeat steps 4 through 6 for the spurs 2 MHz, 3 MHz and 4 MHz above the carrier using respective notch filter adjustments. Note that the 2 MHz spur has an adjustment on the N Loop VCO top cover (A3A4 assembly) as well as on N Loop Divider/Phase Detector top cover (A3A3 assembly). Each is adjusted for minimum spur level. Spur levels for all frequencies should be at least 75 dB below the center frequency (151 MHz) level.

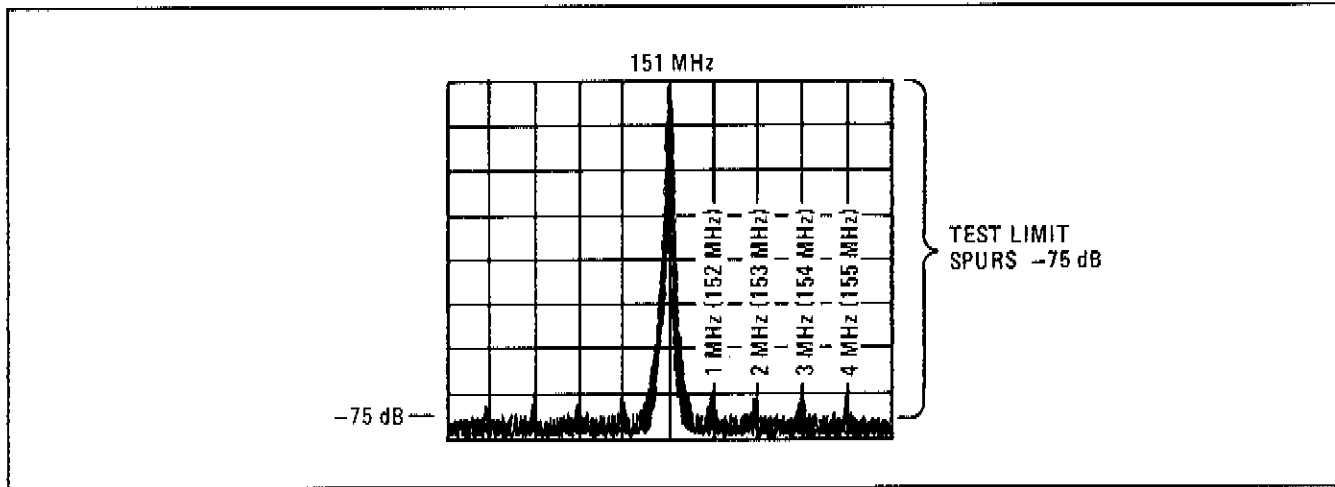

*Figure 5-14. Relationship of 1, 2, 3, and 4 MHz Spurs to the Center Frequency of 151 MHz
(as viewed on the Spectrum Analyzer)*

Adjustment 12

SUM LOOP PHASE ERROR ADJUSTMENT

- Service Sheet 23.

Description

The closed loop phase error signal is adjusted with the POSITION and GAIN controls. POSITION affects the entire range of the VCO; GAIN primarily affects the lower frequencies.

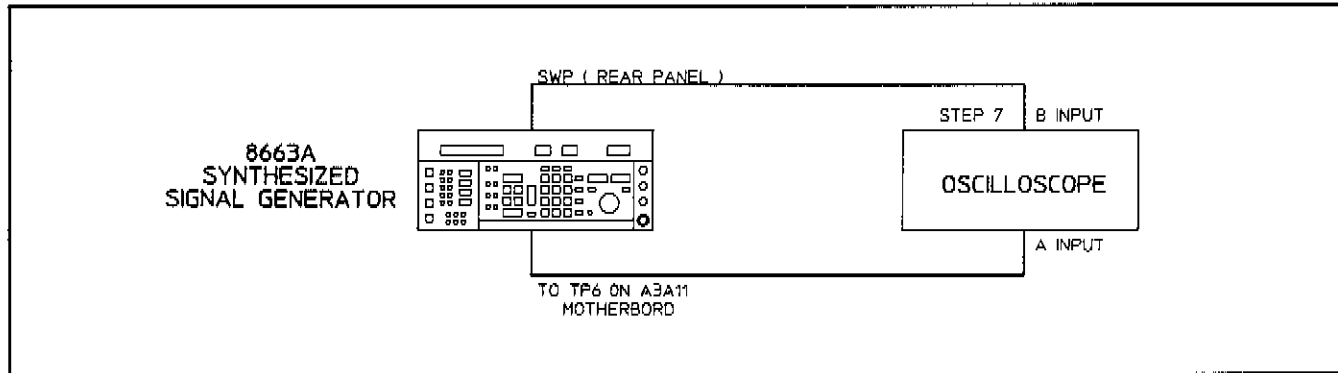

Figure 5-15. Sum Loop Phase Error Adjustment Setup

Equipment

Oscilloscope HP 1741A

NOTE

Refer to Assembly Locations, on foldout at the end of Section 5, for the location of all assemblies referenced in this procedure.

Procedure

1. Set the Signal Generator as follows:

START FREQ	320.00 MHz
STOP FREQ	329.90 MHz
SET SIZE	0.1 MHz
TIME/STEP	0.5 ms
SWEEP MODE	AUTO
2. Set the oscilloscope to X-Y mode.

3. Now, connect the Signal Generator's (SWP) output (rear panel) to the oscilloscope Y input. Connect a test probe from TP6 on the A3A11 Motherboard (bottom side of the instrument) to the X input on the oscilloscope.
4. Adjust POSITION (A3A7R2) and GAIN (A3A7R3) at the top cover of A3A7 assembly until the displayed phase error signal is $0 \pm 0.5V$ throughout the entire sweep.

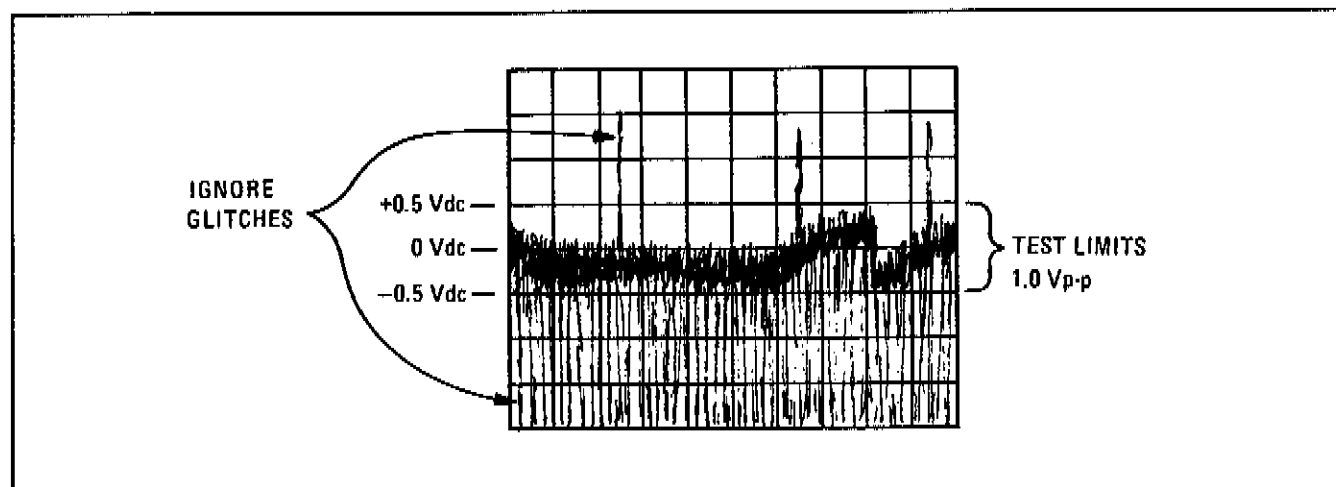

Figure 5-16. Sum Loop Phase Error Signal Waveform (Adjusted Correctly at $0 \pm 0.5V$)

5. After completing this adjustment, confirm that the Low Frequency Section is functioning correctly by viewing ERROR LIGHTS #05, #04, and #03 (on the top covers of A3A10, A3A6 and A3A3, respectively). With the Signal Generator sweeping between 100 kHz and 1.2 GHz, these lights should either be glowing or flashing very dimly. When the SWEEP mode is disabled, these lights should not glow or flash.

ADJUSTMENT 13

FM SUM LOOP PRETUNE ADJUSTMENT

- Service Sheet 26.

Description

The open-loop VCO frequency is adjusted with the POSITION and GAIN controls acting upon the pretune current only.

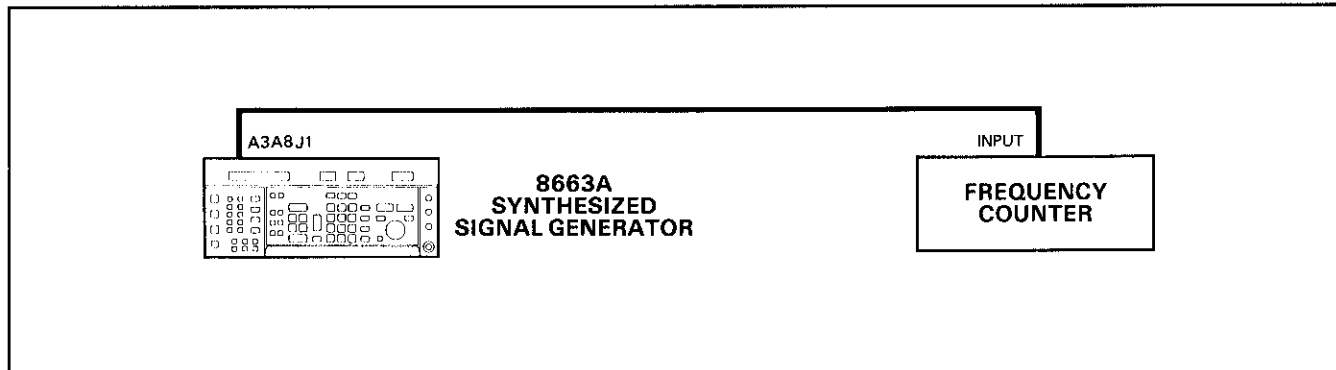

Figure 5-17. FM Sum Loop Pretune Adjustment Setup

Equipment

Frequency Counter HP 5342A Option 031

NOTE

Refer to Assembly Locations, on foldout at the end of Section 5, for the location of all assemblies referenced in this procedure.

Procedure

1. Remove the A3A9 assembly. This opens the phase lock loop. Connect the frequency counter to A3A8J1.
2. Set the Generator to 329.90 MHz with MODULATION and AMPLITUDE turned off.
3. Adjust POSITION (A3A8R3) at the top cover of A3A8, for a counter reading of 201.5 ± 0.5 MHz.
4. Set the Generator to 320.00 MHz.
5. Adjust GAIN (A3A8R4) for a reading of 102.5 ± 0.5 MHz.
6. Steps 2 through 5 are interactive and should be repeated until both frequencies are within limits.
7. After completing this adjustment, confirm that the entire Low Frequency Loop Section is functioning correctly by viewing ERROR LIGHTS #05, #04, and #03 (on the top covers of A3A10, A3A6 and A3A3, respectively). With the Signal Generator sweeping between 10 kHz and 1.2 GHz, these lights should either be glowing or flashing very dimly. When the SWEEP mode is disabled, these lights should not glow or flash.

ADJUSTMENT 14

CONTROLLER BOARD POWER SUPPLY (-30V) ADJUSTMENT

• Service Sheet 5.

Description

The Controller Board's -30 Vdc supply is adjusted.

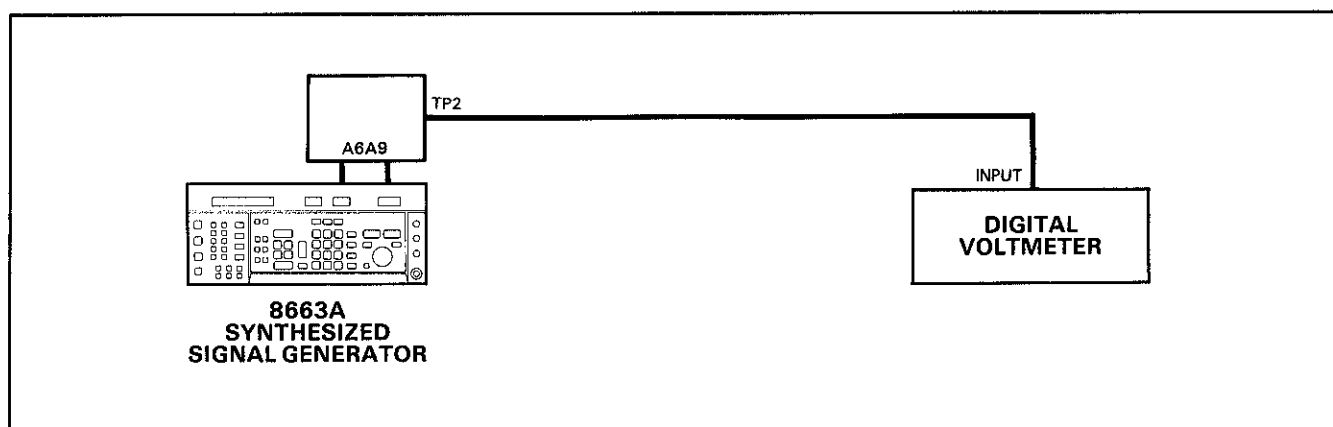

Figure 5-18. Controller Board Power Supply (-30V) Adjustment Setup

Equipment

Digital Voltmeter (DVM)	HP 3466A
Extender Boards (2), 30 pin	HP 08662-60276

NOTE

Refer to Assembly Locations, on foldout at the end of Section 5, for the location of all assemblies referenced in this procedure.

Procedure

1. Place the A6A9 assembly on extender boards (two required).
2. Connect the DVM to A6A9TP2.
3. Adjust the -30 ADJ (A6A9R16) for a DVM reading of -30.00 ± 0.05 Vdc.

ADJUSTMENT 15

REFERENCE SUM LOOP PRETUNE ADJUSTMENT

• Service Sheet 7.

Description

The A6A5R85 GAIN adjustment pot sets the gain of the pretune D/A converter.

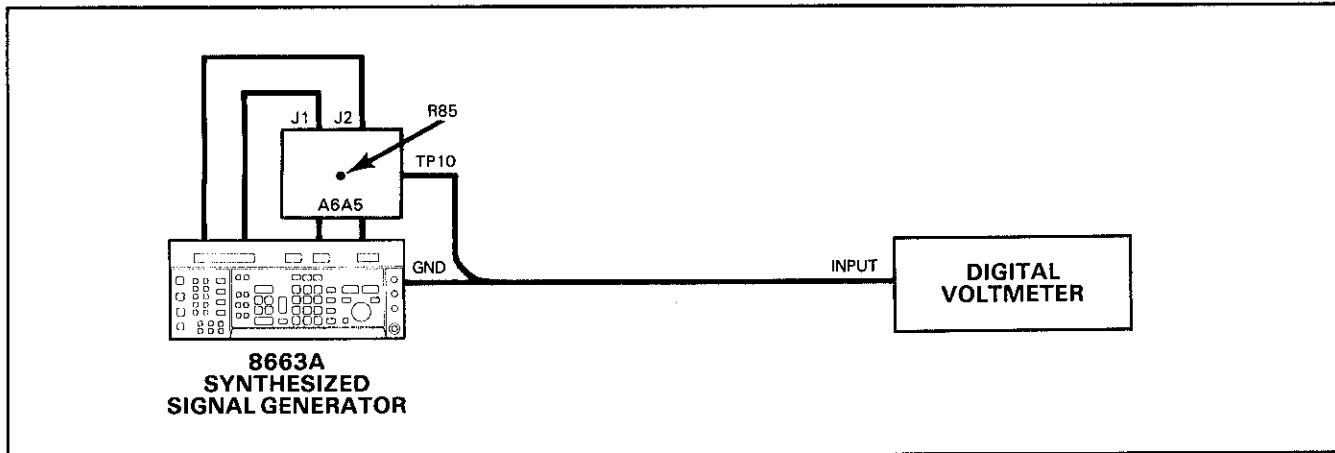

Figure 5-19. Reference Sum Loop Pretune Adjustment Setup

Equipment

Digital Voltmeter (DVM)	HP 3466A
Extender Board, 36 pin	HP 08662-60275

NOTE

Refer to Assembly Locations, on foldout at the end of Section 5, for the location of all assemblies referenced in this procedure.

Procedure

1. Install the A6A5 Assembly on an extender board. Connect the extended length RF cables between A6A5J1 and J2 and the Signal Generator. Connect a cable from A6A5TP10 to the input of the DVM.
2. Set the Signal Generator to a frequency of 320 MHz.
3. Adjust the REF control (A6A5R85) for a reading on the DVM of -3.75 ± 0.01 Vdc.

ADJUSTMENT 16

REFERENCE SUM LOOP OUT-OF-LOCK ADJUSTMENT

- Service Sheet 7 and 8.

Description

The A6A5R156 OUT-OF-LOCK adjustment is set so that the Out-of-Lock Light turns on when the Reference Sum Loop is unlocked (Error No. 06).

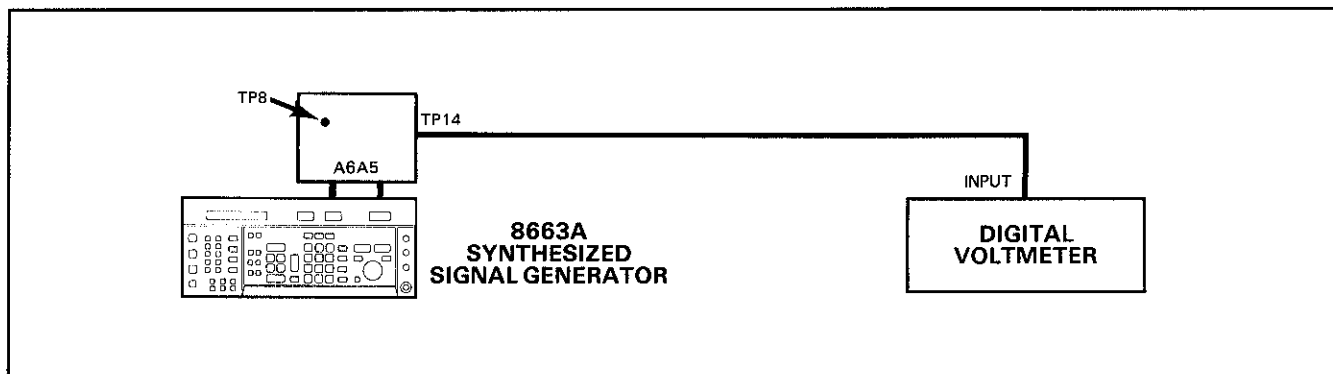

Figure 5-20. Reference Sum Loop Out-of-Lock Adjustment Setup

Equipment

Digital Voltmeter (DVM)	HP 3466A
Extender Board, 36 pin	HP 08662-60275

NOTE

Refer to Assembly Locations, on foldout at the end of Section 5, for the location of all assemblies referenced in this procedure.

Procedure

1. Place the A6A5 Phase Detector on an extender board. Reconnect A6A5J1 (INPUT 10/20 MHz) and A6A5J2 (OUTPUT -9 to -38 VDC) with the extended length RF cables.
2. Connect the DVM to A6A5TP14. Adjust the Generator's output frequency, in 1 MHz increments between 320 and 640 MHz, until the voltage at TP14 equals $+4.5 \pm 1.0$ Vdc.
3. Disconnect the RF cable from A6A5J1 (INPUT 10/20 MHz). The Out-of-Lock Light, Error #06, may or may not turn on. Turn (A6A5R156) fully clockwise. The error LED should be off. Then adjust A6A5R156 until the Out-of-Lock Light just comes on.
4. Reconnect the RF cable to A6A5J1 (the error LED should go out). Connect the DVM to A6A5TP8 and record the dc voltage level.

_____ m Vdc

5. Adjust OFF (A6A5R156) for a voltage level 4 mV higher than the value recorded in step 4.

NOTE

Increasing the voltage at A6A5TP8 by 4 mV ensures that the Out-of-Lock Light still comes on when the instrument is cold and the loop is out of lock.

6. Verify that the Out-of-Lock Light comes on when the loop is unlocked by removing the RF cable from A6A5J1.

ADJUSTMENT 17

OUTPUT SUM LOOP PRETUNE ADJUSTMENT

- Service Sheet 11.

Description

The A6A4R85 REF adjustment sets the gain of the pretune D/A converter.

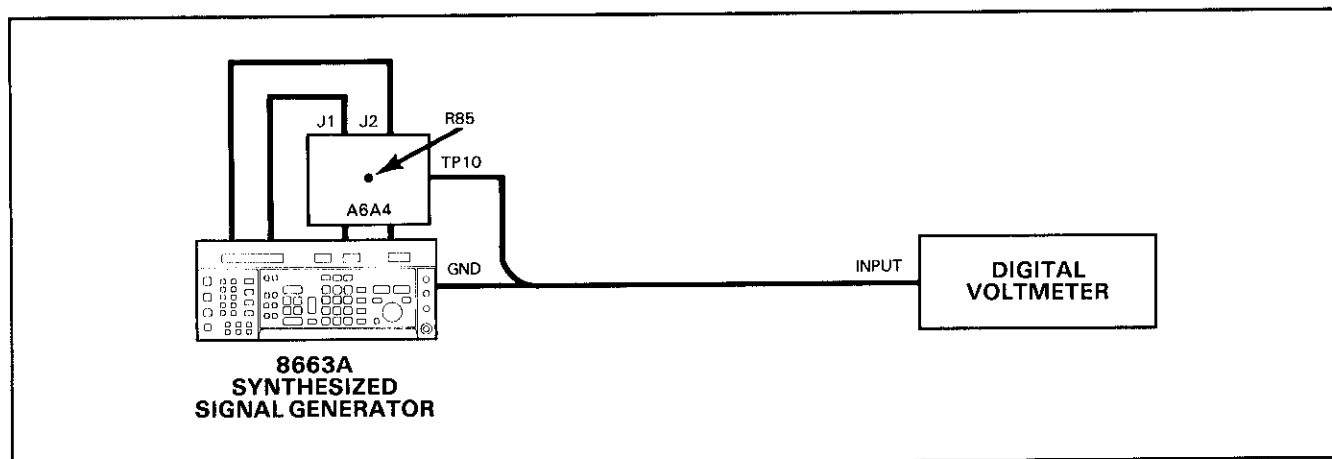

Figure 5-21. Output Sum Loop Pretune Adjustment Setup

Equipment

Digital Voltmeter (DVM)	HP 3466A
Extender Board, 36 pin	HP 08662-60275

NOTE

Refer to Assembly Locations, on foldout at the end of Section 5, for the location of all assemblies referenced in this procedure.

Procedure

1. Install the A6A4 Assembly on an extender board. Connect the extended length RF cables between A6A4J1 and J2 and the Signal Generator. Connect a cable from A6A4TP10 to the input of the DVM.
2. Set the Signal Generator to a frequency of 320 MHz.
3. Adjust the REF control (A6A4R85) for a reading on the DVM of -3.75 ± 0.01 Vdc.

ADJUSTMENT 18

OUTPUT SUM LOOP OUT-OF-LOCK ADJUSTMENT

- Service Sheet 11 and 12.

Description

The A6A4R156 OUT-OF-LOCK pot is set so that the Out-of-Lock Light turns on when the Output Sum Loop is unlocked (Error No. 07).

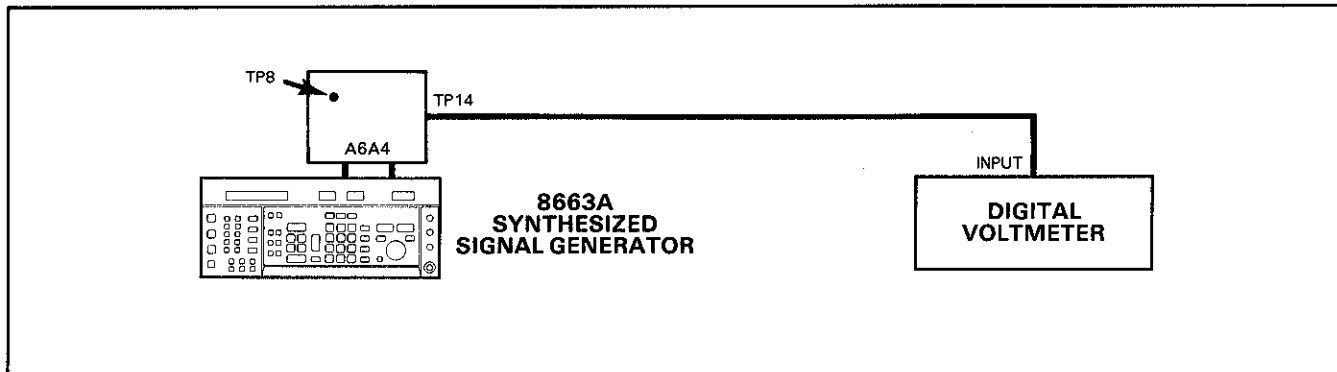

Figure 5-22. Output Sum Loop Out-of-Lock Adjustment Setup

Equipment

Digital Voltmeter (DVM)	HP 3466A
Extender Board, 36 pin	HP 08662-60275

NOTE

Refer to Assembly Locations, on foldout at the end of Section 5, for the location of all assemblies referenced in this procedure.

Procedure

1. Place the A6A4 Phase Detector on an extender board. Reconnect A6A4J1 (INPUT 10-20 MHz) and A6A4J2 (OUTPUT -9 to -38 Vdc) with the extended length RF cables.
2. Connect the DVM to A6A4TP14. Adjust the Generator's output frequency, in 1 MHz increments between 320 and 640 MHz, until the voltage at TP14 equals $+4.5 \pm 1.0$ Vdc.
3. Disconnect the RF cable from A6A4J1 (INPUT 10-20 MHz). The Out-of-Lock Light, Error #07, may or may not turn on. Turn (A6A4R156) fully clockwise. The error LED should be off. Then adjust the OFF control (A6A4R156) until the Out-of-Lock Light just comes on.
4. Reconnect the RF cable to A6A4J1 (the error LED should go out). Connect the DVM to A6A4TP8 and record the dc voltage level. _____ m Vdc
5. Adjust OFF (A6A4R156) for a voltage level 4 mV higher than the value recorded in step 4.

NOTE

Increasing the voltage at A6A4TP8 by 4 mV ensures that the Out-of-Lock Light still comes on when the instrument is cold and the loop is out of lock.

6. Verify that the Out-of-Lock Light comes on when the loop is unlocked by removing the RF cable from A6A4J1.

ADJUSTMENT 19

VARIABLE MODULATION OSCILLATOR (VMO) ADJUSTMENTS.

- Service Sheet 39 and 40.

Description

The offset of the output amplifier of the VMO is adjusted to zero. Flatness adjustments are made on two active filters.

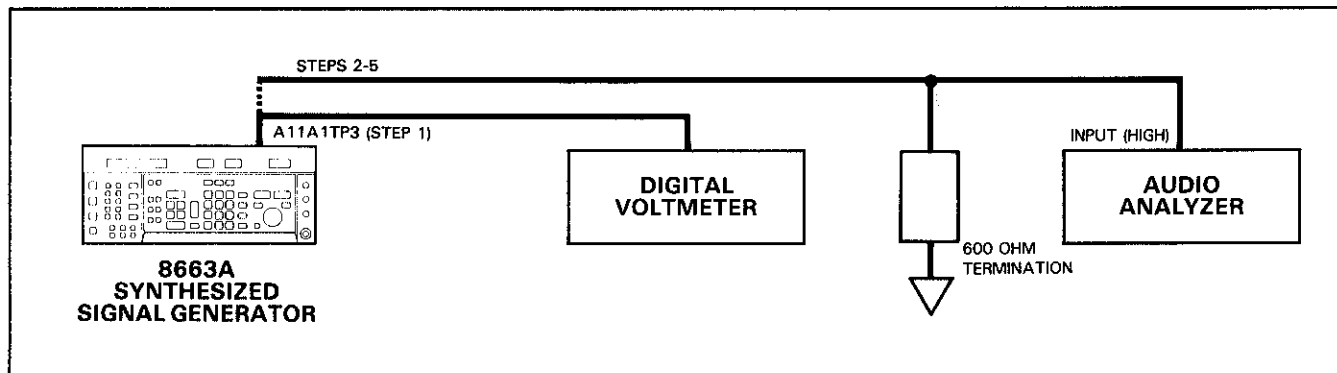

Figure 5-23. VMO Adjustment Setup.

Equipment

Audio Analyzer	HP 8903A
Digital Voltmeter (DVM)	HP 3478A
Termination	(600 ohm)

NOTE

Refer to Assembly Locations, on foldout at the end of Section 5, for the location of all assemblies referenced in this procedure.

Procedure

1. Initialize the Signal Generator (Special Function 00). On A11A1 connect the DVM to TP3 and adjust OFFSET (R60) for a dc voltage reading of 0 ± 0.005 Vdc.
2. Connect the Audio Analyzer input to A11A1TP3. A 600 ohm termination must be connected at the Audio Analyzer input. This termination can be a BNC type feedthrough or an ordinary resistor.
3. Set the Signal Generator modulation frequency to 1.0 kHz. Set the Audio Analyzer to measure AC LEVEL. When the Audio Analyzer reading is stable, push the RATIO key. This reading is now considered 100% and all further readings will be referenced to it.
4. Set the Signal Generator modulation frequency to 31.9 kHz. On VMO adjust 10-32 FLATNESS (R50) for an audio analyzer reading of 100%.
5. Set the Signal Generator modulation frequency to 99.9 kHz. Adjust 32-100 FLATNESS (R43) for an Audio Analyzer reading of 100%.

ADJUSTMENT 20

AM-FM ADJUSTMENTS

- Service Sheets 39, 40, 41, 42 and 43.

Description

The offset of the amplifiers on the A11A5 Modulation Multiplex Assembly are adjusted to zero. Internal levels are adjusted to provide calibrated modulation from both internal and external sources. All adjustments that affect AM and FM are included in this procedure.

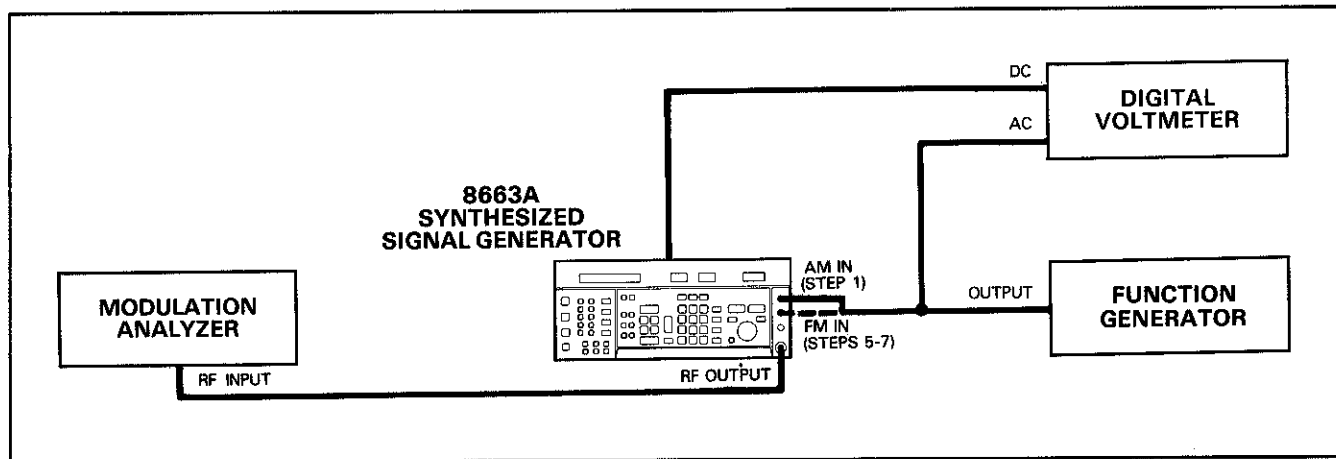

Figure 5-24. AM-FM Adjustment Setup

Equipment

Modulation Analyzer	HP 8901A
Function Generator	HP 3325A
Digital Voltmeter (DVM)	HP 3478A

NOTE

Refer to Assembly Locations, on foldout at the end of Section 5, for the location of all assemblies referenced in this procedure.

Procedure

1. Set the Signal Generator to 100 MHz center frequency, +5.1 dBm output level, AM, 95%, EXT AC source with no input to the front panel AM IN connector. On A11A5 adjust EXT AM OFFSET (R13) for a DVM reading of 0 ± 0.001 Vdc at TP3. Adjust AM OFFSET (R21) for a DVM reading of 0 ± 0.001 Vdc at TP4.
2. Turn AM mode off. Set the Signal Generator to FM, 100 kHz deviation, EXT AC source with no input to the front panel FM IN connector. On A11A5 adjust EXT FM OFFSET (R12) for a DVM reading of 0 ± 0.001 Vdc at TP2. Adjust FM OFFSET (R22) for a DVM reading of 0 ± 0.001 Vdc at TP1.
3. Set the Signal Generator to FM, 0 kHz deviation, EXT DC source with no input to the front panel FM IN connector. On A11A2 adjust DC OFFSET (R18) for a DVM reading of 8.00 ± 0.01 Vdc on TP1.
4. Set the Generator to EXT AC source. On A11A2 adjust FREQ ADJ (C18) for a DVM reading of 8.00 ± 0.05 Vdc on TP1.

5. Connect a cable from the Signal Generator RF OUTPUT connector to the input of the modulation analyzer. Connect the output of the function generator to the front panel FM IN input of the signal generator. Set the output of the function generator to 1 kHz and 0.707 ± 0.0001 Vrms. Set the Signal Generator to 100 kHz FM deviation. On A11A2 adjust MOD Level (R9) for an FM reading of $100 \text{ kHz} \pm 0.1 \text{ kHz}$ peak deviation on the modulation analyzer.
6. With conditions the same as in the previous step turn the HI/LO adjustment (R49) on A11A5 clockwise until the front panel EXTERNAL MOD LO light come on or the end of the adjustment is reached. Note the position of the pot. Then turn this adjustment counterclockwise until the EXTERNAL SOURCE HI light comes on or the end of the adjustment is reached. Set the pot midway between the two points.
7. Set the Signal Generator to FM, INT 1K source and 100 kHz deviation. On A11A1 adjust LEVEL (R71) for a modulation analyzer reading of $100.0 \pm 0.1 \text{ kHz}$ peak deviation.
8. Set the Signal Generator to FM off, AM on, INT 1K source and 90%. Set RF output level to +5.1 dBm. Enable special function 85 (turns off level correction). Set the modulation analyzer to measure AM using the PEAK+ detector. On A4A1 adjust AM LEVEL (R4) for a modulation analyzer reading of $90 \pm 0.1\%$.
9. Set the modulation analyzer to measure AM using the PEAK- detector. On A4A1 adjust AM SYMMETRY (R19) for a modulation analyzer reading of $90 \pm 0.1\%$.
10. Repeat steps 8 and 9 until the modulation analyzer reading is correct at both steps.
11. Enable level correction by executing special function 86.

ADJUSTMENT 21

PHASE MODULATION ADJUSTMENTS (Option 002 only)

- Service Sheets 27, 28, 44 and 45.

Description

Internal signal levels are adjusted so that modulating signals from both internal and external sources produce calibrated amounts of modulation. Bias and compensation adjustments are made to minimize distortion. The detector that lights the front panel EXT SOURCE HI/LO lights is adjusted.

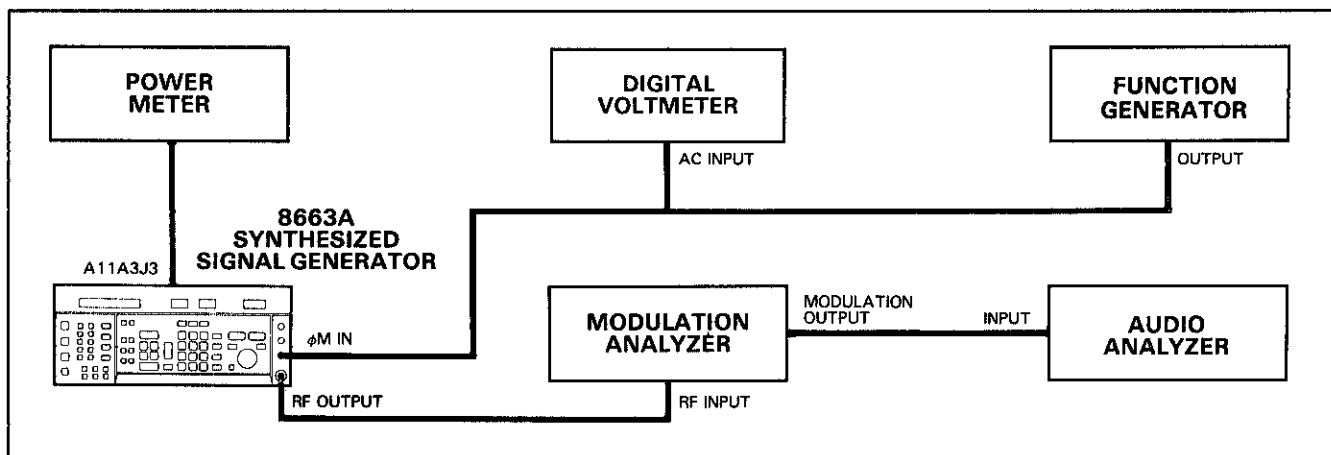

Figure 5-25. Phase Modulation Adjustment Setup.

Equipment

Modulation Analyzer	HP 8901A
Spectrum Analyzer	HP 8566B
Audio Analyzer	HP 8903A
Digital Voltmeter (DVM)	HP 3478A
Function Generator	HP3325A
Power Meter	HP 436A
Power Sensor	HP 8482A
Extender Board, 30 pin	HP 08662-60276
Phase Modulator Extender Kit	HP 08663-60350
Termination (50 ohm)	HP 909A

NOTE

Refer to Assembly Locations, on foldout at the end of Section 5, for the location of all assemblies referenced in this procedure.

Procedure

1. Connect the spectrum analyzer to A4A3J1. Set the spectrum analyzer as follows:

Center Frequency	4 GHz
Frequency Span	100 kHz
Reference Level	-50 dB

A spur should be visible at < -70 dBm with a center frequency of approximately 4 GHz.

- Use the peak search function on the HP 8566B and read the frequency of the spur. The frequency should be approximately 3.9996 GHz.

NOTE

*The spur frequency is calibrated by adjusting A4A3R63. A4A3R63 can be adjusted with a slim probe through the ventilation holes in the side cover of the HP 8663A. It is not necessary to remove the A4A3 board. The 4 GHz oscillator is **NOT** phase locked and the frequency will drift with time, absolute accuracy is not important for the 4 GHz oscillator.*

- Connect the equipment as shown in Figure 5-25 and set the 8663A RF frequency to 50 MHz, RF amplitude to +5 dBm, select phase modulation, 100 degrees, and 50 ohm input impedance (Special Function 70) and EXT AC modulation.
- Set the function generator for a 1 kHz sine wave output at 0.7071 Vrms \pm 0.0005 Vrms. Using a BNC "T" connector and the 50 ohm termination, monitor the voltage with the DVM.
- Disconnect the 50 ohm termination and "T" connector. Connect the modulating signal to the phase modulation input on the 8663A front panel.
- To calibrate the 8901A Modulation Analyzer connect the CALIBRATION output to the RF input and press FM and CALIBRATION. Allow about 1 minute and press phase modulation when the displayed cal factor has settled. Remove the cable and select 17.1 SPEC.
- Connect the 8663A RF output to the 8901A Modulation Analyzer RF input and set the 8901A to measure phase modulation. Select PEAK+, 300 Hz HP FILTER, and >20 kHz LP FILTER.
- Connect the 8901A MODULATION OUTPUT to the 8903A HIGH input and set the Audio Analyzer to read distortion and automatic operation.

NOTE

The two adjustments on the A4A4A4 Phase Modulation Driver Assembly can be made with A4A4 installed in the instrument. Remove the bottom cover of the instrument and make these adjustments through the holes on the A4A5 Motherboard Assembly.

- On the A11A3 PHASE MOD INPUT Assembly, set the phase modulation FLAT adjustment (R82) to the middle of its range. On the 8663A A4A4A4 Phase Modulator Driver adjust BIAS (R3) for minimum distortion on the Audio Analyzer.
- Next adjust DEVIATION (A4A4A4R9) for a reading at approximately 1.745 radians on the Modulation Analyzer.
- Switch to PEAK- and check for the same reading. If readings in PEAK+ and PEAK- modes are not equal adjust BIAS once again as closely as possible for equal readings in both modes.
- Once the readings on PEAK+ and PEAK- are equalized return to DEVIATION and adjust for 1.745 radians.
- The preceding two steps are somewhat interactive and should be repeated until the distortion reading cannot be further reduced. Reinstall the A4A4 Assembly in the instrument.
- Set the 8663A RF output frequency to 500 MHz and on the 8901A Modulation Analyzer select the 3 kHz LP FILTER. Take readings in both the PEAK+ and PEAK- modes of the 8901A. Average the two readings together as follows:

$$\frac{(PEAK+ \text{ reading}) + (PEAK- \text{ reading})}{2}$$

15. On A11A3 adjust phase modulation FLAT (R82) until the average reading is 1.745 ± 0.005 radians.
16. On the A11A3 Assembly adjust HI/LO (R48) counter clockwise until the front panel EXT MOD LO light comes on or the end of the adjustment is reached. Note the position of the adjustment. Then turn the adjustment clockwise until the EXT MOD HI light comes on or the end of the adjustment is reached. Set the adjustment midway between the two points.
17. Set the Signal Generator to 600 ohm Phase Modulation input impedance (Special Function 71). Select the 600 ohm output of the function generator. Set the function generator output level to 0.7071 Vrms as measured on the DVM.
18. On the A11A3 Assembly adjust 600 ohm INPUT LEVEL (R20) for a Modulation Analyzer reading of 1.745 radians averaged as before between the PEAK+ and PEAK- readings. The input level will change with the adjustment so several iterations may be required to obtain the correct result as the input level is kept at exactly 0.7071 Vrms.
19. Select INT 1K on the Signal Generator. On the A11A3 Assembly adjust phase modulation INT (R5) for a Modulation Analyzer reading of 1.745 radians averaged as before between the PEAK+ and PEAK- readings.
20. Mount the A11A3 Phase Modulation Input Assembly on an extender board. Only the cable that attaches to J1 must be connected. Connect the power sensor to the J3 connector of A11A3.
21. Set the function generator to 100 kHz and use the 600 ohm output of the function generator. Enable Special Function 71 (600 ohm phase modulation input) on the Signal Generator. Measure the power level and set db [REF] on the power meter at this level.
22. Change the function generator frequency to 1.0 MHz. Adjust the PEAKING control (C8) on A11A3 for a power meter reading of 0 ± 0.1 dB. Reinstall the A11A3 assembly in the instrument.

ADJUSTMENT 22

PHASE MODULATION SPUR ADJUSTMENT (Option 002 only)

- Service Sheet 45.

Description

The drive level to the input mixer is adjusted to keep a spurious signal within specifications.

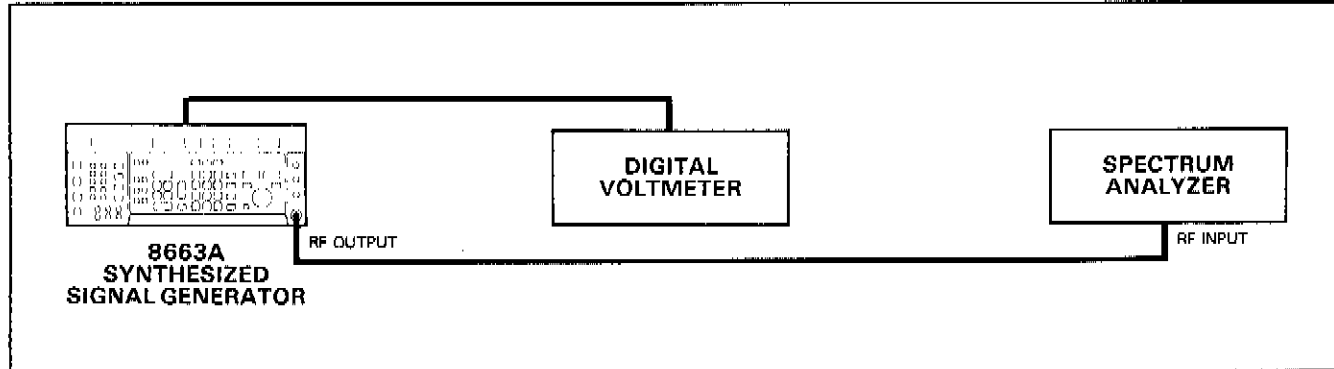

Figure 5-26. Phase Modulation Spur Adjustment Setup.

Equipment

Spectrum Analyzer	HP 8565A
Digital Voltmeter (DVM)	HP 3478A
Phase Modulator Extender Kit	HP 08663-60350

NOTE

Refer to Assembly Locations, on foldout at the end of Section 5, for the location of all assemblies referenced in this procedure.

Procedure

1. Initialize the Signal Generator (Special Function 00), and then set output frequency to 571.42857 MHz and output level to 0 dBm. Turn on phase modulation and set to 0 degrees deviation and EXT AC source but with no connection to the front panel PM IN connector.
2. Adjust the spectrum analyzer to view the RF output of the Signal Generator with 500 kHz/div frequency span. Set the signal at the first vertical division on the left side of the display. Set the reference level of the spectrum analyzer to the signal amplitude.
3. Remove the A4A4 Phase Modulator Assembly and install it on the test mounting bracket and connect with the test cables from the service kit.
4. Connect the DVM to measure the DETECTOR TP (on the resistor lead) through an opening in the cover of the A4A4A1 assembly.
5. Turn the MIXER DRIVE LEVEL adjustment on A4A4A1 fully clockwise. This should cause the spur to become visible on the spectrum analyzer. If the spur is not visible, tune the spectrum analyzer to find it.

6. Tune the spectrum analyzer so the spur is in the center of the display. Reduce resolution BW and decrease the reference level so the noise level is below -90 dBm.
7. Adjust MIXER DRIVE LEVEL on A4A4A1 to minimize the spur while keeping the DVM reading below 50 mVdc. The spur must be below -83 dBm.
8. Reinstall the A4A4 assembly in the instrument.

ADJUSTMENT 23

BPSK ADJUSTMENTS (Option 002 Only)

- Service Sheets 44.

Description

BPSK accuracy is adjusted by looking for the carrier null that occurs at 90 degrees deviation.

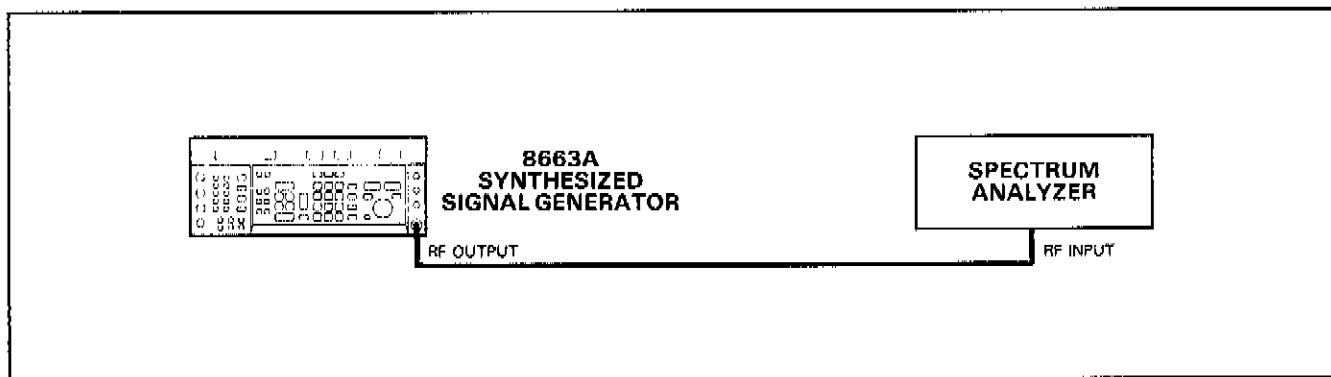

Figure 5-27. BPSK Adjustment Setup.

Equipment

Spectrum Analyzer HP 8565A

NOTE

Refer to Assembly Locations, on foldout at the end of Section 5, for the location of all assemblies referenced in this procedure.

Procedure

1. Initialize the Signal Generator (Special Function 00), and then set output frequency to 1.0 GHz and output amplitude to +10.0 dBm. Turn on BPSK and set mod frequency to 10.0 kHz.
2. View the signal on the spectrum analyzer at 20 kHz resolution BW. On the A11A3 assembly of the Signal Generator adjust BPSK (R3) to null the carrier.

ADJUSTMENT 24

OUTPUT AMPLIFIER BIAS ADJUSTMENTS

- Service Sheet 34 and 35.

Description

The bias of the output amplifier is adjusted to minimize harmonics.

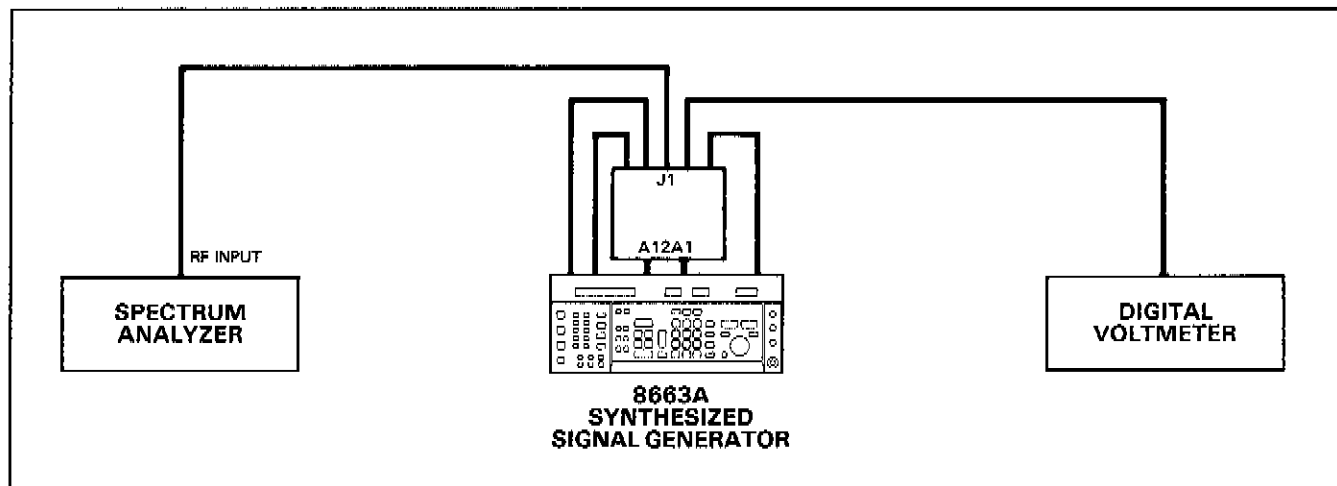

Figure 5-28. Output Amplifier Bias Adjustment Setup.

Equipment

Spectrum Analyzer	HP 8565A
Digital Voltmeter (DVM)	HP 3478A
Extender Board, 30 pin	HP 08662-60276

NOTE

Refer to Assembly Locations, on foldout at the end of Section 5, for the location of all assemblies referenced in this procedure.

Procedure

1. Initialize the Signal Generator (Special Function 00), and then set output amplitude to +16.0 dBm. On the Generator's sweep (left) keyboard set the following:

START FREQ	100 kHz
STOP FREQ	119.9 MHz
STEPS	1000
MODE	MANUAL
2. On the Signal Generator mount the A12A1 assembly on an extender board. Connect a test cable from the J1 connector of this assembly to the input of the spectrum analyzer. Use extender cables to connect the normal inputs to J2, J3 and J4.
3. Use the Signal Generator knob to tune the output frequency to 119.9 MHz. View the signal on the analyzer display and set the reference level to the signal amplitude. Then set the spectrum analyzer to sweep from 10 to 240 MHz.
4. Connect the DVM to measure the differential dc voltage between TP8 and TP9 on the A12A1 assembly. Adjust BAND BIAS LO (R6) for a DVM reading of 0.10 ±.001 Vdc.

5. Use the knob on the Signal Generator to tune the output frequency over the sweep range. The spectrum analyzer should display the harmonics. Determine the Signal Generator frequency setting that produces the highest harmonic. Then set the Generator to that frequency and view the harmonic on the spectrum analyzer.
6. Adjust BAND BIAS LO (R6) clockwise to reduce the harmonic 35 dB below the reference level, however, the DVM reading must be greater than 0.10 Vdc. Do not minimize the harmonic because this could cause harmonics to increase at other frequencies.
7. Repeat steps 5 and 6 until the harmonic is below 35 dB at all frequencies in the sweep range.
8. Set the Signal Generator output frequency to 500 MHz and set SWEEP mode to OFF. Connect the DVM to measure the differential dc voltage between TP4 and TP5 on the A12A1 assembly. Adjust DRIVER BIAS (R26) for a DVM reading of 15 mVdc.
9. Connect the DVM to measure the differential dc voltage between TP8 and TP9 on the A12A1 Assembly. Adjust Band Bias HI (R31) for a DVM reading of 215 mVdc.
10. Change the Signal Generator sweep settings to the following

START FREQ	120.0 MHz
STOP FREQ	2559.9 MHz
STEPS	1000
MODE	MANUAL
11. Use the knob to set the Signal Generator output frequency to 2559.9 MHz. View the signal on the spectrum analyzer and set its reference level to the signal amplitude. Then set the spectrum analyzer to sweep from 240 to 5200 MHz. If the spectrum analyzer being used does not cover this range in one band, you must switch bands to see the entire span.
12. Use the signal Generator's knob to tune the output frequency over the sweep range. View the harmonics on the spectrum analyzer and determine the frequency setting that produces the highest harmonic. Set the Generator to this output frequency and view the harmonics on the spectrum analyzer. Adjust BAND BIAS HI (R31), if needed, to reduce the harmonic 33 dB below the reference level, however, the DVM reading cannot be greater than 235 mVdc. Do not minimize the harmonic as this could cause harmonics to increase at some other frequency.
13. Repeat steps 10 and 11 until harmonics at all frequencies in the sweep range are less than 35 dB below the reference level.

ADJUSTMENT 25

RF LEVEL ADJUSTMENTS

- Service Sheets 34, 35, 36 and 37.

Description

An adjustment is made to eliminate bias changes to the output amplifier microcircuit when switching between bands. The detector circuitry offset and output level accuracy is adjusted

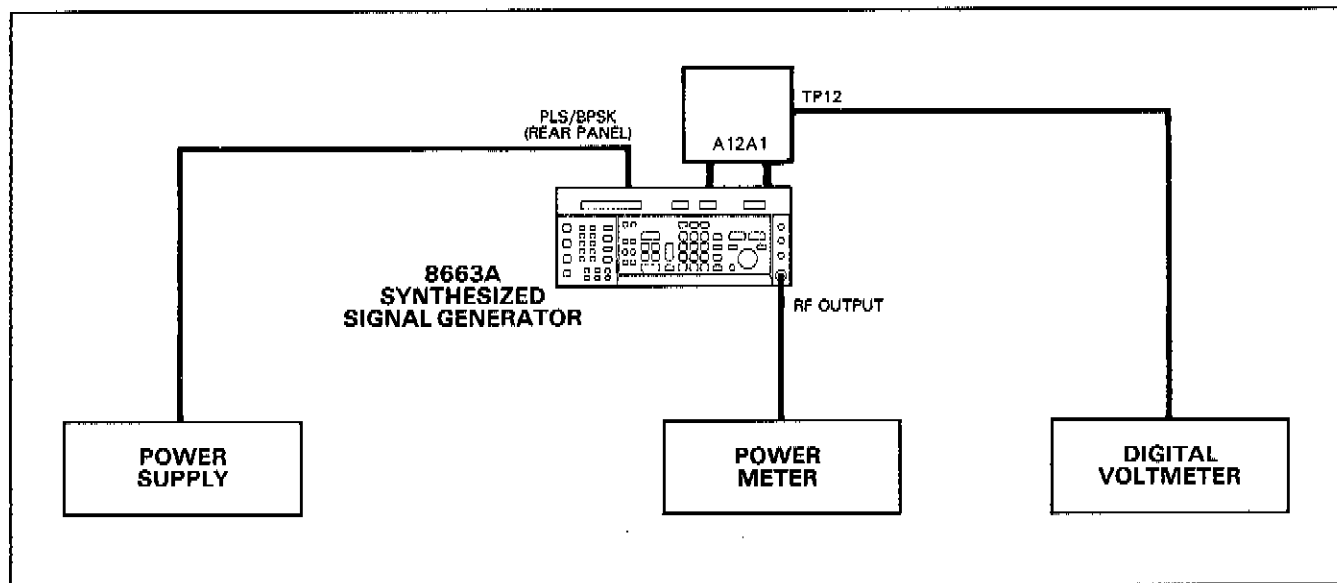

Figure 5-29.. RF Level Adjustments Setup.

Equipment

Power Meter	HP 436A
Power Sensor	HP 8482A
Digital Voltmeter (DVM)	HP 3478A
Power Supply	HP 6234A
Extender Card, 30 pin	HP 08663-60276

NOTE

Refer to Assembly Locations, on foldout at the end of Section 5, for the location of all assemblies referenced in this procedure.

Procedure

1. Initialize the Signal Generator (Special Function 00). Remove the A12A1 assembly from the Signal Generator and mount this assembly on an extender board, but do not connect any of the cables that normally go to this assembly. Then set the Generator RF output frequency to 119.0 MHz and frequency increment to 1.0 MHz.
2. Connect the DVM to measure the dc voltage on TP12 of the A12A1 assembly.

3. Set the Signal Generator output frequency to 120.0 MHz. Note the DVM reading. Use the increment down key to change the frequency to 119.0 MHz. Adjust OFFSET CROSS BAND (R12) on the A12A1 assembly so the DVM reading is the same at both frequency settings. Ignore the initial transient that occurs from changing frequencies and compare values once the reading has stabilized. DVM readings should be within 1 mVdc.
4. Disconnect the cables from the top of the A12A1 assembly. Set the power supply to +5.0 Vdc and connect the output of the power supply to the PLS BPSK input on the Signal Generator rear panel.
5. The DVM should be connected to TP12 of the A12A1 assembly. Note the DVM reading. Enable pulse modulation with EXT DC source. Adjust OFFSET PULSE (R61) on A12A1 for the same DVM reading.
6. Install the A12A1 assembly in the Signal Generator and connect all the cables. Initialize the Signal Generator and set:

SPECIAL FUNCTION	85 (level correction off)
AMPLITUDE	+5.1 dBm
AMPLITUDE INCREMENT	4.9 dB
7. Connect the power meter to measure the output level from the Signal Generator. Adjust OFFSET AM (R64) on A12A1 for a power meter reading of +5.1 dBm.
8. Press the increment up key which sets the AMPLITUDE to +10.0 dBm and adjust CW LEVEL (R8) on the A4A1 assembly for a power meter reading of +10.0 dBm.
9. The adjustments in steps 7 and 8 are interactive. Repeat these steps until the power levels are within 0.1 dB of the correct value in each step.
10. Select Special Function 86 to enable level correction.

ADJUSTMENT 26

ALC LOOP BANDWIDTH ADJUSTMENTS

- Service Sheet 36 and 37

Description

The loop gain of the four ALC bands is adjusted. If loop gain is too low, AM accuracy may not meet specifications and if loop gain is too high, the loop may not be stable. Other adjustments are made on the Doubler #2 ALC loop.

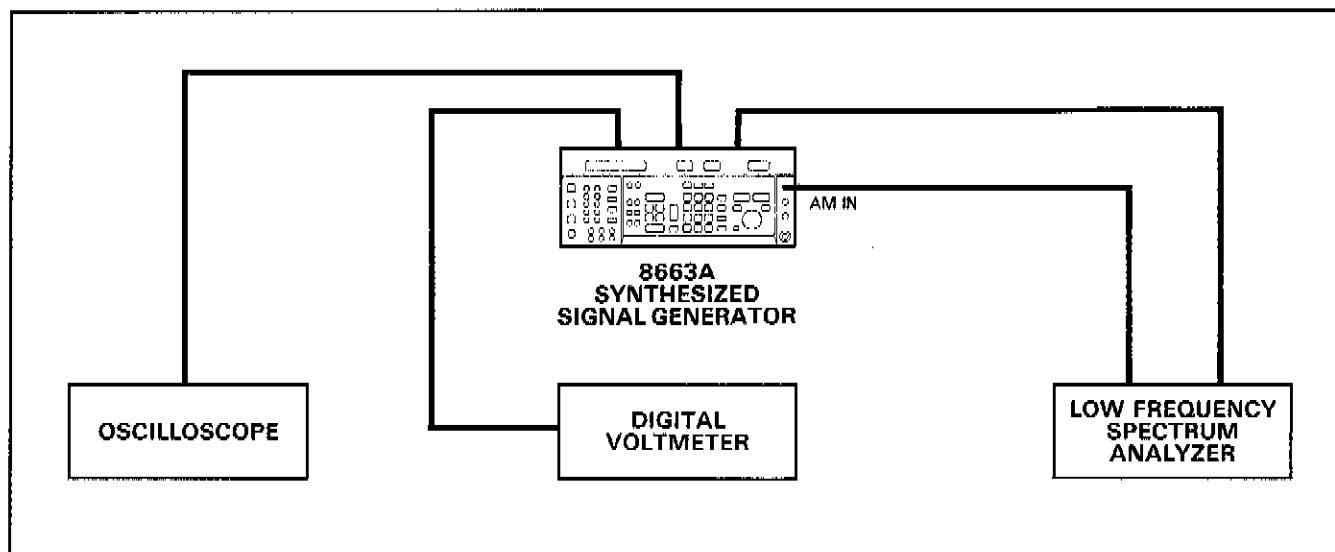

Figure 5-30. ALC Loop Bandwidth Adjustments Setup.

Equipment

Low Frequency Spectrum Analyzer	HP 8556A/8552B/141T
Digital Voltmeter (DVM)	HP 3478A
Oscilloscope	HP 1741A
Extender Board, 48 Pin	HP 08663-60347

NOTE

Refer to Assembly Locations, on foldout at the end of Section 5, for the location of all assemblies referenced in this procedure.

Procedure

1. On the Signal Generator mount the A4A1 assembly on an extender board. The cable that goes to J1 does not have to be connected. Connect a test cable from the spectrum analyzer input to TP4 on the A4A1 assembly. Connect a cable from the spectrum analyzer tracking generator output to the Signal Generator front panel AM IN connector. Terminate the Signal Generator RF Output with a 50 ohm load.

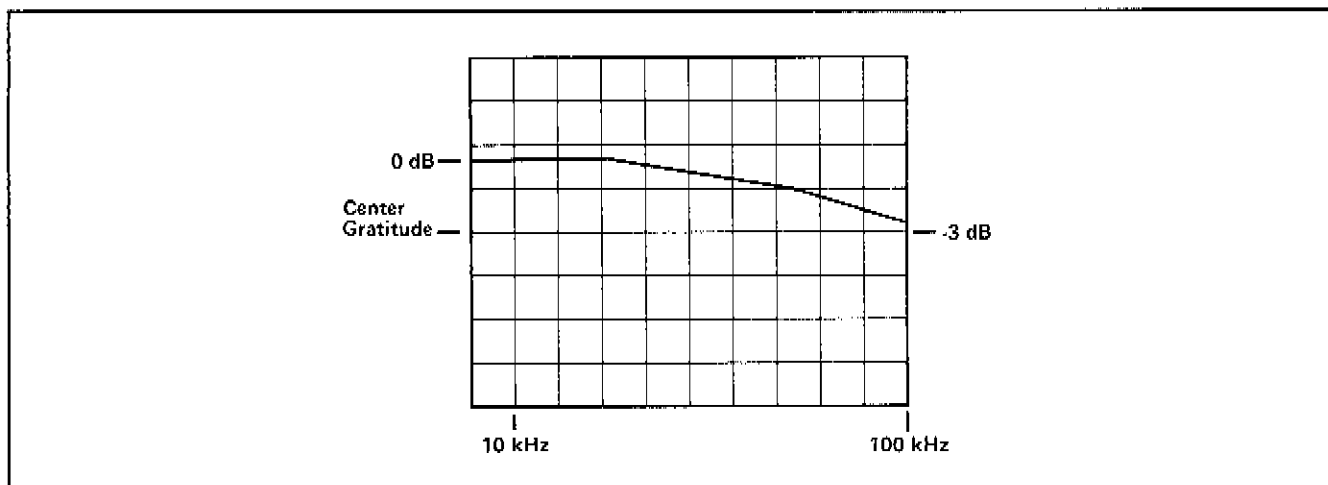

Figure 5-31. Spectrum Analyzer Display.

Table 5-4. ALC Loop Bandwidth Frequency Ranges

Band	Start Freq	Stop Freq	Adjustment
DOWN CONV	10.0 MHz	119.9 MHz	HET LOOP GAIN (R23)
MID	120.0 MHz	639.9 MHz	UHF LOOP GAIN (R22)
DOUBLER#1	640.0 MHz	1279.9 MHz	DOUBLER #1 (R24)
DOUBLER#2	1280.0 MHz	2559.9 MHz	DOUBLER #2 (R25)

2. Initialize the Signal Generator (Special Function 00) and set as follows:

SIGNAL GENERATOR:

START FREQ see table 5-4
 STOP FREQ see table 5-4
 STEPS 100
 SWEEP MODE MANUAL
 SPECIAL FUNCTION 85
 AMPLITUDE +5.1 dBm
 AM 90% with EXT AC source

SPECTRUM ANALYZER:

CENTER FREQUENCY 50 MHz
 BANDWIDTH 3 kHz
 LIN SCAN WIDTH 10 kHz/division
 INPUT LEVEL -40 dBm
 INPUT IMPEDANCE 600 ohm
 SCAN TIME/DIVISION 2 ms
 AMPLITUDE SCALE 2 dB log

3. Adjust the Tracking Generator output level until both the EXT MOD LO and HIGH lights are extinguished on the 8663. Set the Spectrum Analyzer reference level for a waveform similar to the one shown in Figure 5-31. The low frequency portion of the trace (10 kHz) should be 3 dB above the center line of the screen.

4. Use the knob on the Signal Generator to tune the output frequency over the sweep range given in the table. Observe the trace on the spectrum analyzer and determine the Signal Generator output frequency setting at which the trace is lowest where it crosses the 100 kHz point (see Figure 5-30). When the low setting is found, readjust the reference level for +3 dB at the 10 kHz point. Then set the Generator to this output frequency and on the A4A1 assembly make the adjustment shown in the table so that the trace crosses the center line (-3 dB) at the 100 kHz point.
5. Repeat step 4 to insure that the spectrum analyzer display is above the center line at the 100 kHz point for all output frequency settings in the band being checked.
6. Perform steps 2 - 5 for the first three entries in the table. Do not do these steps yet for the Doubler #2 band.
7. Connect the DVM to measure the dc voltage on TP14 of the A4A1 assembly. Set the Signal Generator:

SWEEP	OFF
FREQUENCY	2.0 GHz
AMPLITUDE	+16.0 dBm
MODULATION	OFF
SPECIAL FUNCTION	85
8. Adjust DOUBLER #2 DRIVE (R34) on A4A1 for a DVM reading of 10.1 ± 0.1 Vdc.
9. Connect an oscilloscope probe to TP1 of A4A1. Set the oscilloscope to 50 mV/div (5 mV/div if a 10:1 probe is used). Use ac coupling and 1 msec/div sweep speed.
10. Set the Signal Generator:

FREQUENCY	1.7 GHz
AMPLITUDE	+5.1 dBm
AM	20% with INT 1K source
11. Adjust LOCAL ALC OFFSET (R38) on A4A1 until a sine wave can be seen on the oscilloscope. Then adjust this same control to null the sine wave.
12. The previous two adjustments are interactive. Repeat steps 7-11 until the specified result is obtained in both adjustments.
13. Remove the oscilloscope probe from TP1. Remove the DVM cable from TP14. Set the Signal Generator as specified in step 2 and perform the adjustment in steps 2-5 for the DOUBLER #2 BAND.

ADJUSTMENT 27

PULSE MODULATION DRIFT ADJUSTMENTS

- Service Sheets 36 and 37.

Description

The offset of amplifiers on the Output Amplifier assembly (A12A1) and the ALC assembly (A4A1) are adjusted to provide the best operation during pulse modulation.

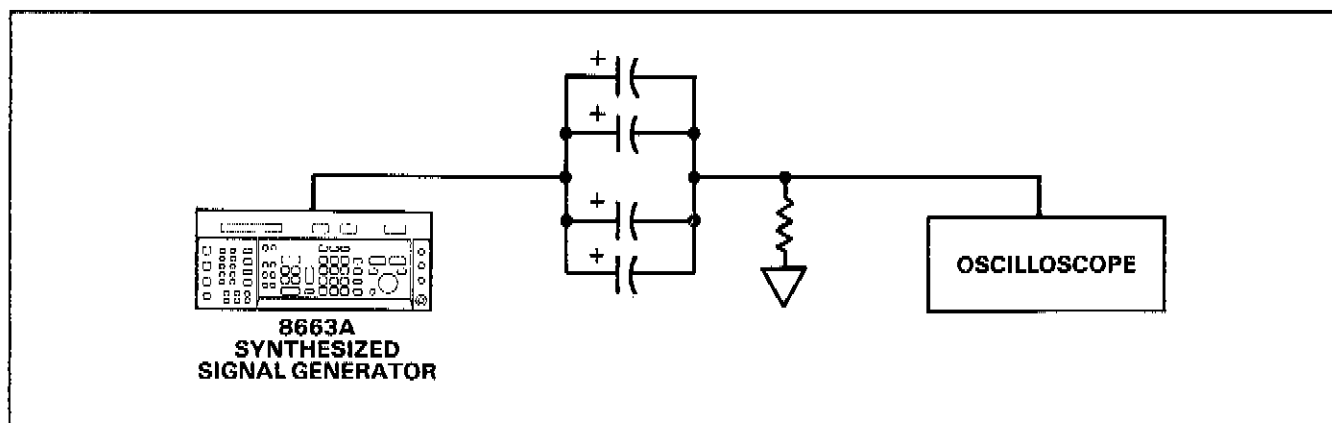

Figure 5-32. Pulse Modulation Drift Adjustments Setup.

Equipment

Oscilloscope	HP 1741A
Capacitors (4)	470 Microfarad Tantalum, >35 V
Resistor	1.96 k Ω
Extender Board, 48 pin	HP 08663-60347

NOTE

Refer to Assembly Locations, on foldout at the end of Section 5, for the location of all assemblies referenced in this procedure.

Procedure

1. Mount the A4A1 Assembly on an Extender Board. Initialize the Signal Generator (Special Function 00) and set as follows:

OUTPUT FREQUENCY	1.0 GHz
OUTPUT AMPLITUDE	+5.1 dBm
SPECIAL FUNCTION	85 (level correction off)
MODULATION	Pulse, with 50 Hz internal rate
2. Connect the oscilloscope probe to TP1 which is accessible through the top cover of the A4A1 assembly. Set the scope to DC coupling, 56 mV/div sensitivity, and 5 msec/div sweep speed. Connect the resistor and capacitor as shown in the setup. Adjust the scope TRIGGER LEVEL to stabilize the display.
3. The display should be a square wave with low amplitude. On the A4A1 assembly turn the MAIN ALC DRIFT (R107) adjustment and notice the effect on the waveform. One side of the waveform will tilt. Set the adjustment so the adjustable half of the waveform is horizontal.

4. Remove the RC coupling network and set the oscilloscope to 2 volts/division. Set the Signal Generator as follows:

START FREQ	1.5 GHz
STOP FREQ	2.559 GHz
LIN STEPS	1000
SWEEP MODE	MANUAL
5. Observing the dc level on the oscilloscope, turn the knob and view the voltage variations. Note the lowest voltage observed across the frequency band (this low limit should occur several times across the selected frequency band).
6. Using the knob, set the Signal Generator to a frequency where the dc level observed on the oscilloscope is approximately 1 volt higher than the low limit observed in the previous step.
7. Re-connect the RC network as shown in Figure 5-32, and set the oscilloscope to 5mV/division sensitivity. On A4A1, adjust LOCAL ALC DRIFT (R106) for the same result as in step 3.

ADJUSTMENT 28

LOW FREQUENCY DOWN CONVERTER ADJUSTMENT

• Service Sheet 29.

Description

The A12A5C16 Low Frequency Down Converter Adjustment variable capacitor (located on the component side of the A12A5 board) sets the tuned amplifier's frequency response and gain so that the signal entering the LO Input of the A12A5U2 mixer is properly matched to the mixer's requirements.

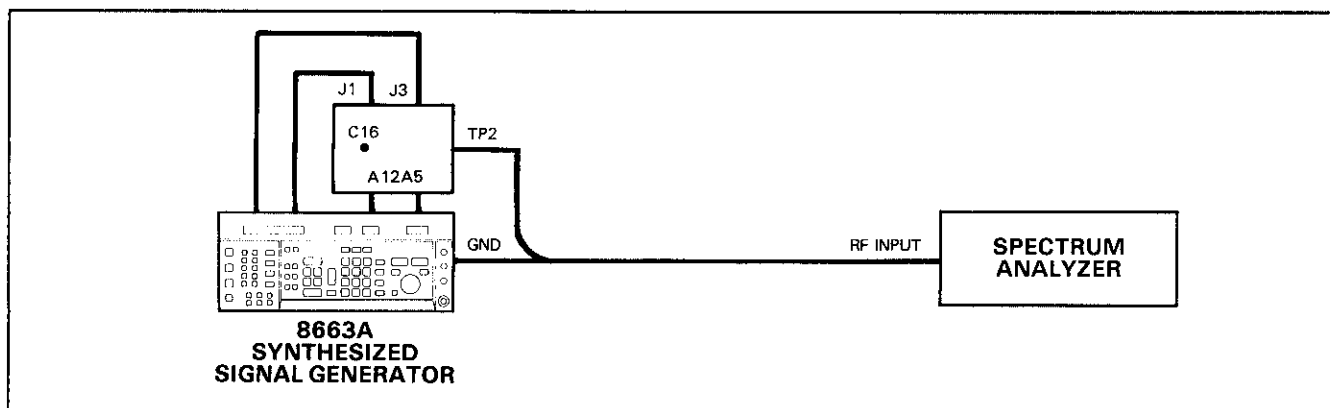

Figure 5-33. Low Frequency Down Converter Adjustment Setup

Equipment

Spectrum Analyzer, RF	HP 8558B/141T
Extender Board, 20 Pin	HP 08662-60277
RF Test Probe, AC coupled	1250-1598

NOTE

Refer to Assembly Locations, on foldout at the end of Section 5, for the location of all assemblies referenced in this procedure.

Procedure

1. Install the A12A5 assembly on an extender board. Connect the extended length RF cables between A12A5J1, J3 and the Signal Generator. Connect a cable from A12A5TP2 to the 50 ohm input of the spectrum analyzer using the special AC coupled RF test probe found in the service kit.
2. Set the Signal Generator as follows:

START FREQ	10 kHz
STOP FREQ	120 MHz
SWEEP STEPS	1000
TIME/STEP	2 ms
SWEEP MODE	AUTO
MODULATION	MOD OFF
3. Set the spectrum analyzer to sweep between 520 and 640 MHz, with 1 MHz resolution bandwidth, +20 dBm reference level and +5 dB per vertical division.
4. Adjust A12A5C16 so that the swept-frequency response is flat within ± 1 dB at a power level above +10 dBm.

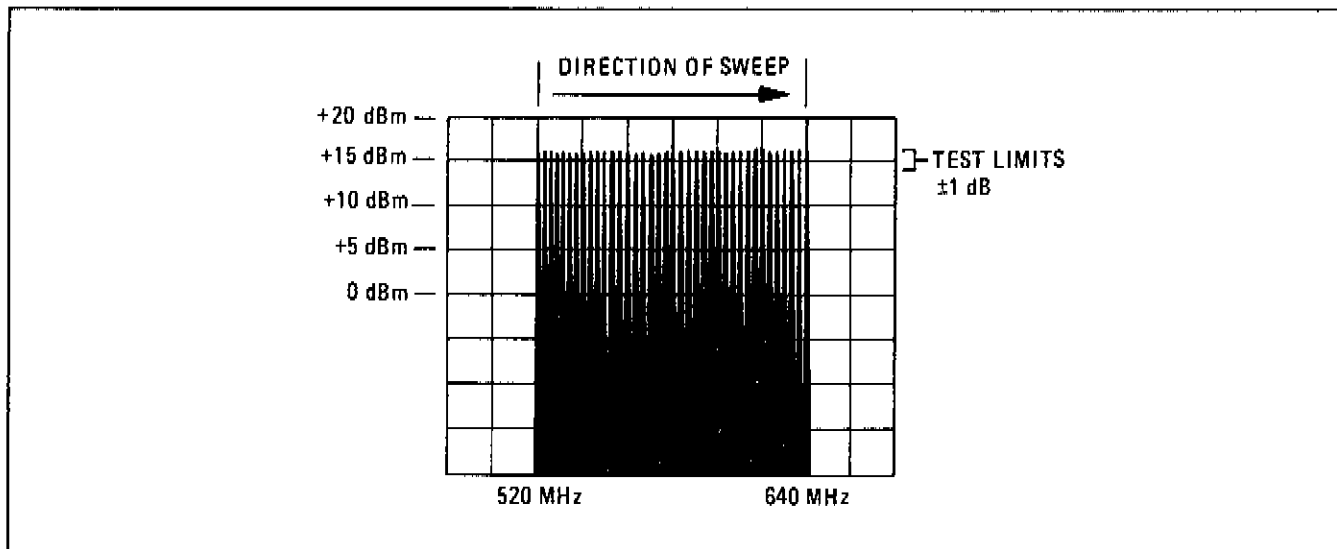

Figure 5-34. Adjustment of Flattest Frequency Response (within ±1 dB)

ADJUSTMENT 29

LOW PASS FILTER ADJUSTMENTS

- Service Sheets 27, 28 and 31.

Description

Low pass filters on the A4A3 Distributor Assembly and A12A2 UHF Modulator Assembly are adjusted. The adjustment criteria for all these filters is:

1. Rejection of ± 38 dB at the second harmonic of the lowest frequency in the pass band.
2. Ripple of less than ± 1 dB in the pass band.

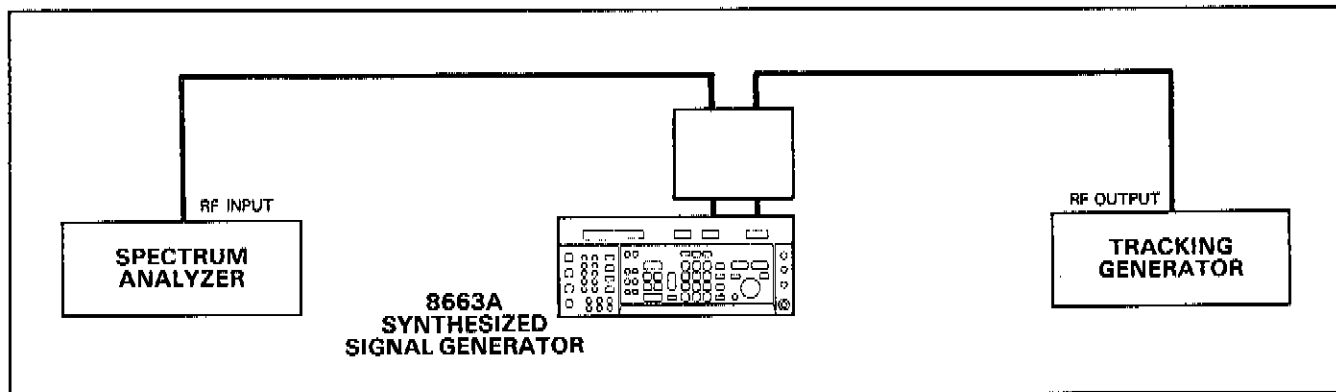

Figure 5-35. Low Pass Filter Adjustment Setup.

Equipment

Spectrum Analyzer	HP 8565A
Tracking Generator	HP 8444A Option 059
Extender Board, 30 Pin	HP 08662-60276

NOTE

Refer to Assembly Locations, on foldout at the end of Section 5, for the location of all assemblies referenced in this procedure.

Procedure

1. Remove the top cover of the Signal Generator. Mount the A4A4 Distributor Assembly on an extender board. Disconnect all the RF cables that go to the top connectors of this assembly. They must remain unconnected during the adjustments on this assembly.
2. Set the output level of the tracking generator to 0 dBm. Connect a test cable from the RF output of the tracking generator to the J1 connector of the A4A3 assembly. Connect a test cable from the J4 connector of A4A3 to the RF input of the spectrum analyzer.

Table 5-5. A4A3 Distributor Adjustments

Signal Generator (MHz)	Spectrum Analyzer Sweep Range (MHz)	Pass Band (MHz)	-38 dB At (MHz)	Adjust A4A3
400.0	320 - 720	460	640	C43,C49
600.0	440 - 1040	660	880	C42,C48

3. Set the Signal Generator to the frequency given in the first column of the preceding table. Set the spectrum analyzer frequency and frequency span to cover the frequency range given in the second column of the table. Adjust the capacitors listed in the last column of the table for the following response:
4. Flat to within ± 1 dB from 320 MHz to the frequency listed in the "FLAT TO" column of the table.
5. Rejection of > -38 dB at the frequency listed in the "-38 dB AT" column of the above column.
6. Repeat step 3 using the frequencies in the second line of the above table.
7. This completes adjustment of the A4A3 assembly. Reinsert the A4A3 assembly into the Signal Generator. Connect all the normal RF cables to the top of the assembly. 6. Remove the A4A1 ALC Assembly from the Signal Generator. This assembly must be out of the instrument for the next adjustment. Mount the A12A2 UHF Modulator Assembly on an extender board. Disconnect the RF cables that connect to the top of this assembly. On the A12A2 assembly short together TP3 and TP4.
8. Connect a test cable from the output of the tracking generator to the J1 connector of A12A2. Connect another test cable from the J2 connector of A12A2 to the input of the spectrum analyzer.

Table 5-6. A12A2 UHF Modulator Adjustments

Signal Generator (MHz)	Pass Band (MHz)	-25 dB (MHz)	-35 dB (MHz)	Adjust A12A2
140.0	120 - 160	240	360	C31,C46
200.0	160 - 220	320	480	C32,C48
300.0	220 - 320	440	660	C30,C45
400.0	320 - 450	640	1000	C34,C47
500.0	450 - 640	900	1000	C29,C44

9. Set the Signal Generator to the frequencies in the first column of Table 5-6. At each frequency setting adjust the capacitors listed in the last column of the table for the following response as viewed on the spectrum analyzer:
10. Peak to peak amplitude variations of less the 3.5 dB within the frequency range given in the PASS BAND column of the table.
11. Amplitude down more than 25 dB from the pass band level at the frequency listed in the -25 dB column of the table.
12. Amplitude down more than 35 dB from the pass band level at the frequency listed in the -35 dB column of the table.

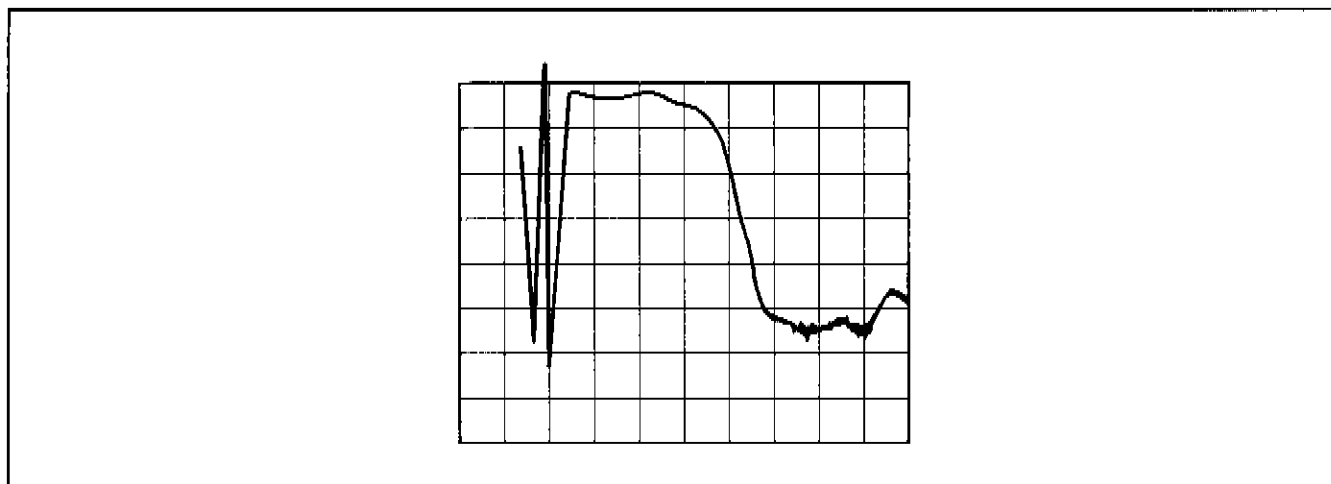

Figure 5-36. Low Pass Filter Response

13. Remove the jumper from A12A2 and reinstall the A4A1 and A12A2 in the Signal Generator. Connect all the normal cables to both assemblies.

ADJUSTMENT 30

Z-AXIS MARKER LEVEL ADJUSTMENT

- Service Sheets 56,57.

Description

The A2A2R7 ZMRK adjustment pot sets the level of the Z-axis intensity marker. The Z-axis marker level is adjustable over a range of -2 to -8 V peak.

NOTE

Figure 5-43 illustrates a typical output waveform from the Z-AXIS BLKG-MKR connector.

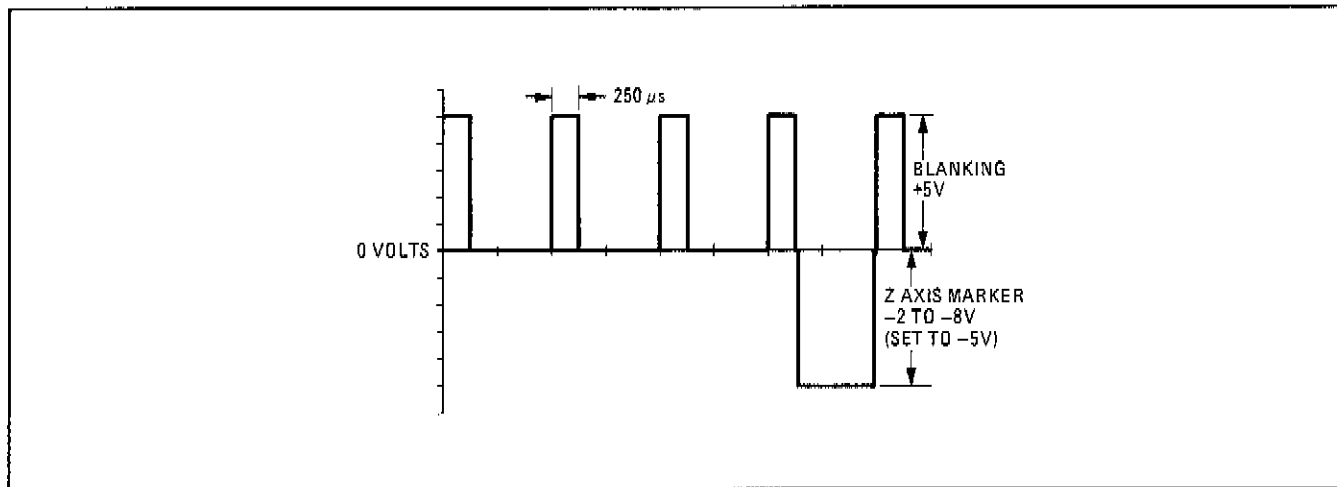

Figure 5-37. Typical Waveform from the Z-AXIS BLKG-MKR Connector

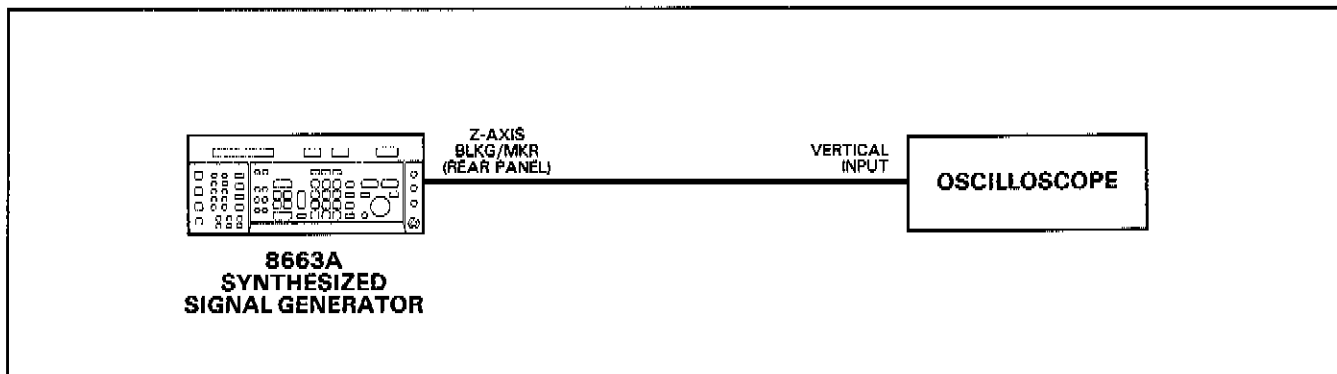

Figure 5-38. Z-Axis Marker Level Adjustment Setup

Equipment

Oscilloscope HP 1741A

NOTE

Refer to Assembly Locations, on foldout at the end of Section 5, for the location of all assemblies referenced in this procedure.

Procedure

1. Connect the Z-AXIS BLKG/MKR output (on rear panel) to the vertical input of the oscilloscope.
2. Set the oscilloscope's time base controls to 0.5 ms per division and internal trigger (negative slope); set the vertical controls to 2 volts per division with dc coupling.
3. Set the Signal Generator's controls as follows:

START FREQ	1 MHz
STOP FREQ	10 MHz
STEP SIZE	1 MHz
TIME/STEP	1 ms
MODE	AUTO
MARKER 1	1 MHz
MARKER 2	5 MHz
4. Adjust the ZMRK control, A2A2R7, to the desired Z-axis marker level (-2 to -8V). The Z-axis marker level is adjusted at the factory for $-5.0 \pm 0.2V$.

10 MHz REFERENCE OSCILLATOR
FINE FREQUENCY ADJUST

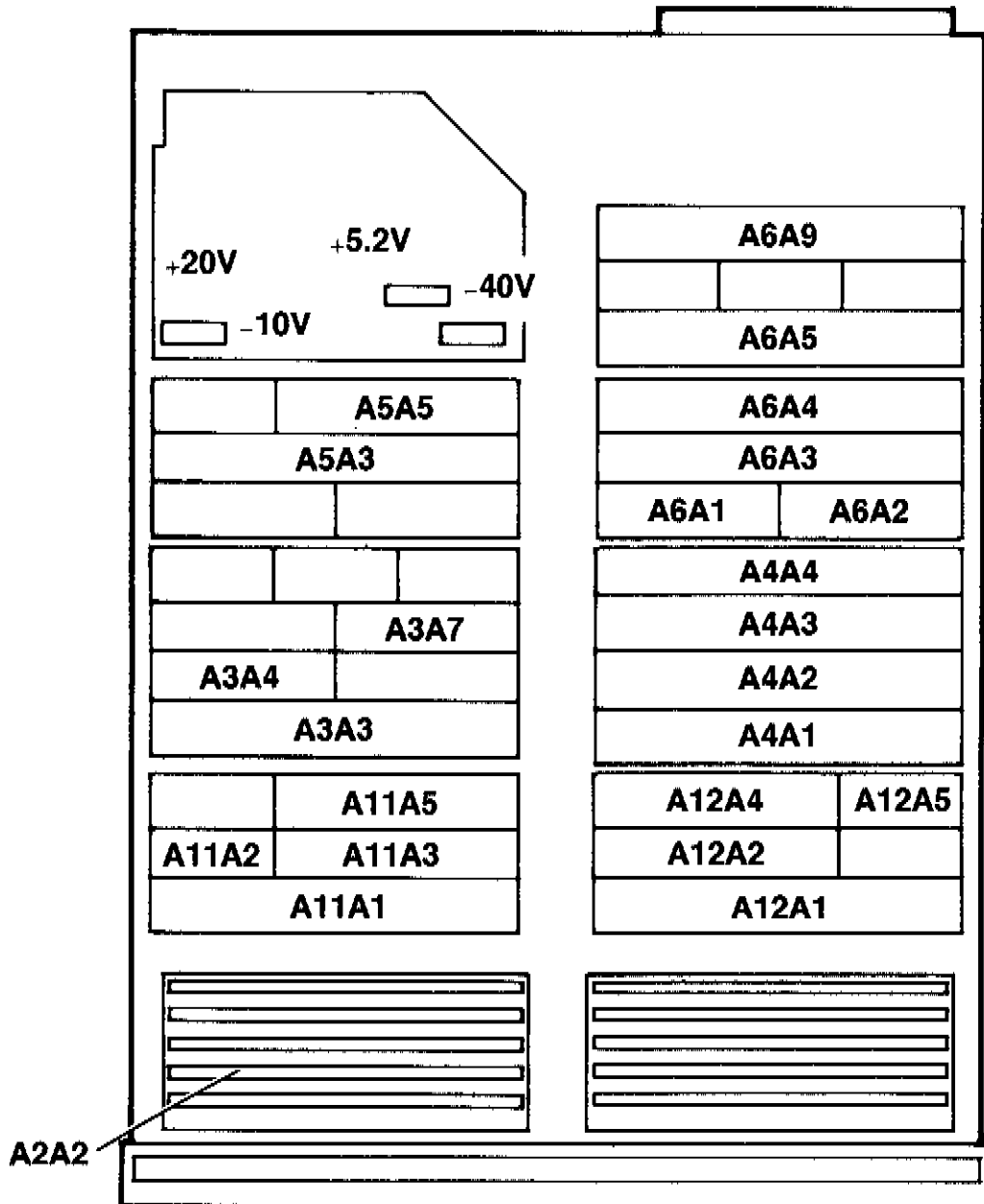

Assembly Locations